



SEA KING HAS.6/AEW

04450-0389

©2001 BY REVELL AG.

PRINTED IN POLAND

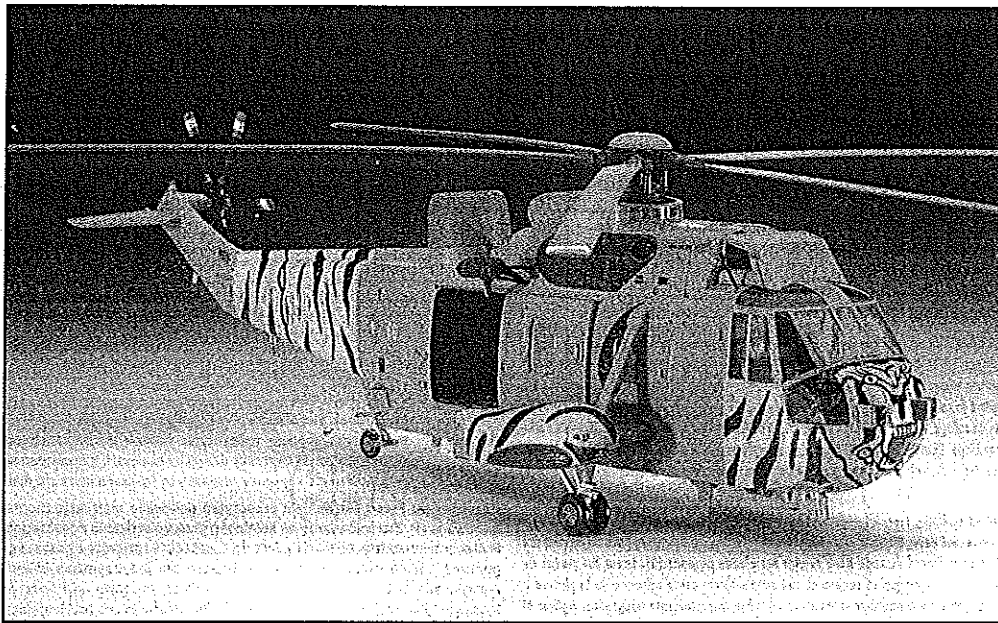

SEA KING HAS.6/AEW

1966 erhielt die Firma Westland Helicopters in Großbritannien den Auftrag über 60 Hubschrauber in der Lizenz für die Royal Navy zu fertigenden Version des berühmten Sikorsky S-61/SH-3 Sea King. Im Jahre 1969 wurden die ersten Maschinen in Dienst gestellt. Angetrieben von Rolls Royce H-1300 Gnome Turbomotoren und mit britischer Avionik ausgerüstet, führte der Erfolg der Ausführung HAS. Mk.1 zur Weiterentwicklung zum HAS.2, der erstmals den Sechsstab-Heckrotor aufwies, zum Rettungshubschrauber HAR.3 S&R für die RAF und zum Royal Navy HC.4 Truppentransporter (diese Version wurde unter der Bezeichnung „Commando“ auch exportiert). Die Westland-Sea-King-Varianten wurden in viele andere Länder exportiert, einschließlich Australien, Belgien, Ägypten, Deutschland, Indien, Norwegen, Pakistan, Qatar und Saudi Arabien. Die weitere Entwicklung führte zum HAS. Mk.5 mit MEL-Sea-Searcher-Radar in einem größeren Radom unter dem Rumpf, modernisierter Avionik-Ausstattung und neuer Sonar-Bojen-Ausrüstung, die ab 1981 zum Einsatz kam. Während des Falkland-Krieges im Jahre 1982 verfügten die britischen Truppen über keinerlei Frühwarnsystem gegen Luftangriffe - ein kostspieliger Fehler, der zum Verlust von wichtigen Kriegsschiffen führte. Ein Notprogramm brachte den Sea King AEW.2, bei dem der Rumpf so konvertiert wurde, dass das Frühwarn-Radar mit seinem festen Radom an einem abklappbaren Schwenkarm untergebracht werden konnte. Er wurde erstmals im August 1982 von der 824. Staffel eingesetzt. Ende 1982 wurde die traditionelle Frühwarnereinheit der Navy, die 849. Staffel, reaktiviert, um die AEW 2/2A einzusetzen. Diese verblieb im Einsatz und wird zurzeit durch die neue AEW.7 ersetzt. Die aktuelle Ausführung zur U-Boot-Bekämpfung ist die HAS.6, die seit 1988 bei der 824. Staffel im Dienst steht. Obwohl sie der Mk.5 ähnelt, wurden sowohl die digitale Bordavionik als auch die integrierte Radarausstattung komplett modernisiert. Zudem kommen Rotorblätter aus Composit-Material zur Anwendung. Die ersten fünf Exemplaren sind neu gebaute Hubschrauber, während es sich bei weiteren 73 um umgerüstete Mk.5 handelt. Der HAS.6 wird von fünf weiteren Staffeln geflogen und ist bis zur vollständigen Einführung des neuen Merlin HM.1 der wichtigste Hubschrauber der Royal Navy zur U-Boot-Bekämpfung. Stärkere Gnome H-1400-1-Turbomotoren mit 1.118,5 kW (1.500 WPS) Leistung ermöglichen eine Höchstgeschwindigkeit von 259 km/h (161 mph) und eine Reichweite von 1.229 km (764 Meilen). Hauptrotordurchmesser: 18,89 m (62 feet). Rumpflänge: 17 m (55 feet + 9,75 inch). Höhe: 5 m (16 feet + 6 inch). Bewaffnung: eine Vielzahl von Wasserbomben und Sting Ray selbstsuchenden bzw. drahtgelenkten Torpedos.

SEA KING HAS.6/AEW

In 1966 Westland Helicopters in the UK received an order for 60 licence-built versions of the famous Sikorsky S-61/SH-3 Sea King for the Royal Navy; the first of these entered service in 1969. Powered by Rolls Royce H-1300 Gnome turboshaft engines and fitted with British avionics, the success of the HAS. Mk.1 version soon led to further developments with the upgraded HAS.2, which first introduced the six-bladed tail rotor; the search and rescue HAR.3 for the RAF and the Royal Navy HC.4 troop carrier, this version also exported as the Commando. Westland Sea King variants have been exported to several other nations including Australia, Belgium, Egypt, Germany, India, Norway, Pakistan, Qatar and Saudi Arabia. Further development led to the HAS. Mk.5, which featured the MEL Sea Searcher radar in a larger dorsal radome, upgraded avionics fit and new sonobuoy equipment; these entered service in 1981. During the Falklands War of 1982, British forces lacked any form of airborne early warning - a costly mistake which led to the loss of important warships. An emergency programme led to the Sea King AEW.2, airframes being converted to carry search radar housed in an inflatable radome mounted on a swivelling arm; they were first operated by No. 824 Squadron in August 1982. In late 1982 No.849 Sqn., the Navys traditional early warning unit, was reactivated to operate the AEW 2/2As, these remaining in service and currently being replaced with the new AEW.7. The current anti-submarine variant is the HAS.6, which first entered service with No. 824 Squadron in 1988. Although similar to the Mk.5, its internally housed digital avionics and integrated radar equipment is completely upgraded and composite rotor blades are fitted; the first five were new-build aircraft and a further 73 are conversions of Mk.5s. The HAS.6 has served with five other squadrons and remains the Royal Navys main anti-submarine helicopter pending introduction of the new Merlin HM.1 into full service. More powerful Gnome H-1400-1 turboshaft engines, each rated at 1,118.5kW (1,500 shp), give it a maximum speed of 259km/h (161mph) and a range of 1,229km (764 miles.). Main rotor diameter: 18.89m (62ft.) Fuselage length: 17m (55ft 9.75in.) Height: 5m (16ft 6in.) Armament: a variety of depth charges and Sting Ray homing torpedoes.

Form hergestellt und im Eigentum von Revell AG/Revell Monogram Inc. Widersetzliche Nachahmungen werden gerichtlich verfolgt.
Ce produit est propriété de la société Revell AG/Revell Monogram Inc. Toute utilisation ou duplication frauduleuse sera l'objet de poursuites en justice.
Modelado y en propiedad de Revell AG/Revell Monogram Inc. Infracciones ilícitas serán perseguidas por la ley.
Forma prodotta dalla Revell AG/Revell Monogram Inc. e di proprietà della stessa impresa, la quale procederà legalmente contro ogni imitazione abusiva.
Malli on Revell AG/Revell Monogram Inc. valmistama ja omalsuutla. Läättömaan kopiointiin tullaan puuttamaan oikeudelliset toimen.
Formen er produsert og dies av Revell AG/ Revell Monogram Inc. Etterigning uten tillatelse vil bli gjenstand for rettslig forfølgelse.
Produkcja i prawa własności firmy Revell AG/Revell Monogram Inc. Nielegalne podrabianie jest zabronione pod odpowiedzialnością sądową.
Model, Revell AG/Revell Monogram Inc. firmasının mülkiyeti altında legal edilmiştir. Kaçunsa ayılmı tükümler mahkumata tabii edilecektir.
A forma elaborada é a tulajdonjog bírósága a Revell AG/Revell Monogram Inc. A jogellenes utánzások és hamisításnyal bíróságlag üldözök.

Mould manufactured by and property of Revell AG/Revell Monogram Inc. Illegal imitations are subject to prosecution.
Vorm vervaardigd door en eigendom van Revell AG/Revell Monogram Inc. Onrechtmatige nabootsingën worden gerechtelijk vervolgd.
Formas produzidas e de propriedade da Revell SA/Revell Monogram Inc. Cópias não autorizadas serão processadas jurisdicçamente como determinado na lei.
Modelen tillverkad av och tillhör Revell AG/Revell Monogram Inc. All kopiering behövas enligt lagen om upphovsrätt.
Formen er fremstillet af Revell AG/Revell Monogram Inc. som også har ejendomsret. Lovstridige efterligninger søgtes.
Molden katasvatanca a mallasena cedevncazovca firma Revell AG/Revell Monogram Inc. Iprerovnan ovnca vodkazne presetravca a svrabiva vopozna.
H jeczny autokopievatnyer kan napravljen ovnca vlcenpola tny Revell AG/Revell Monogram Inc. Oj napodobnyy juplonyy; vo kazdomyx vopoznyy.
Tvar byl vytvořen firmou Revell AG/Revell Monogram Inc. a je jejím vlastním. Proti razobkopym napodobováním se bude postopovat soudně cestou.
Forma je proizvedena in je vlasništvo Revell AG/Revell Monogram Inc. Neovlašena kopija bodo pravno kažnjena.

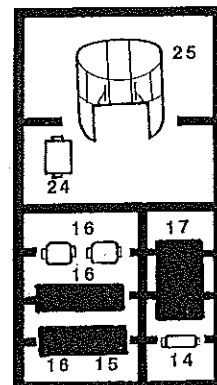
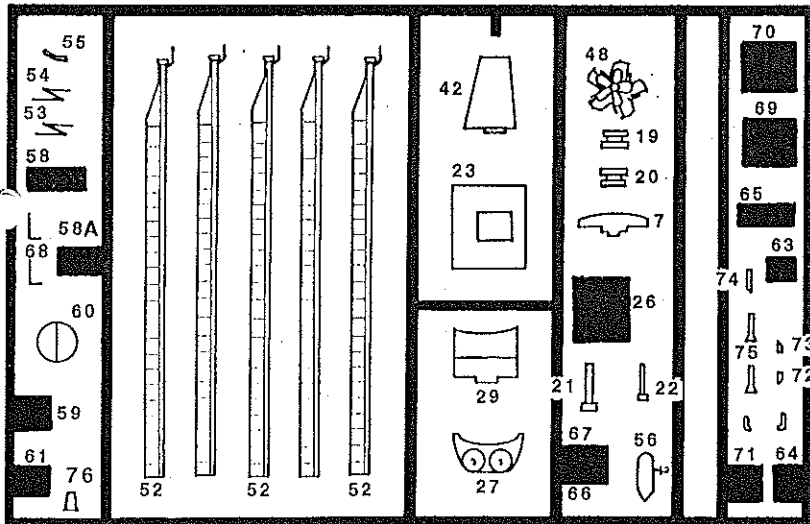
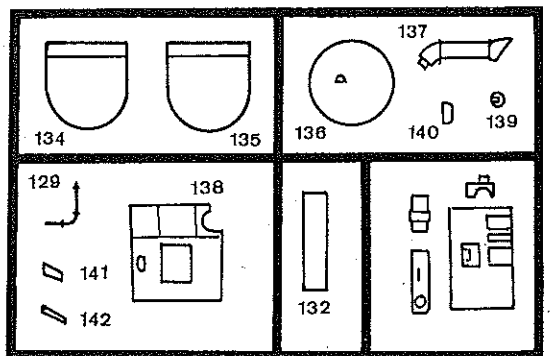
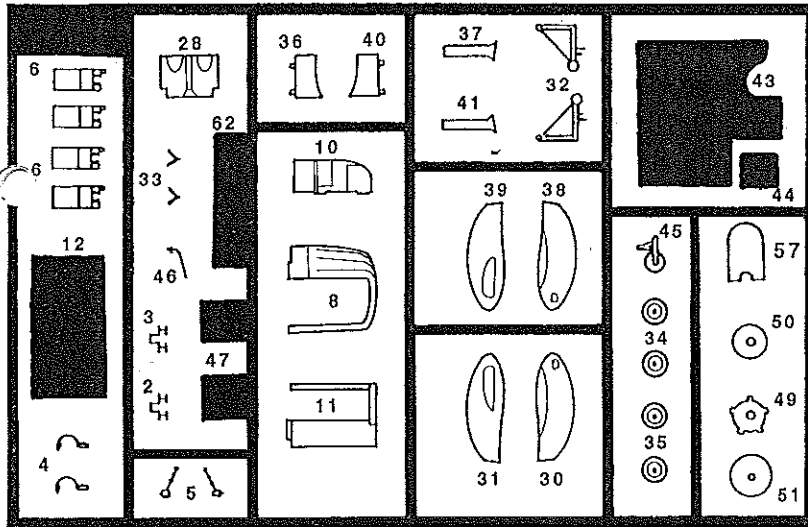
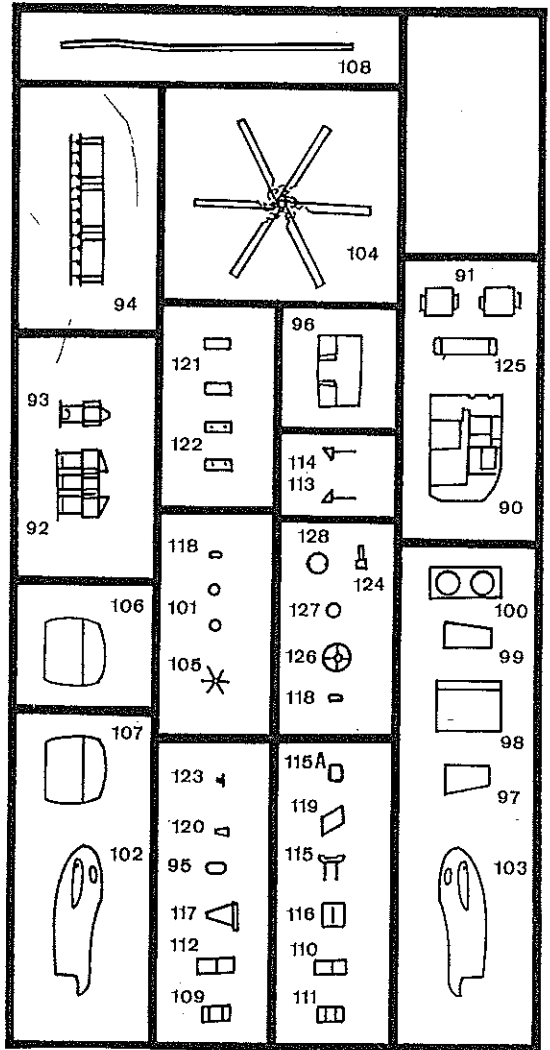
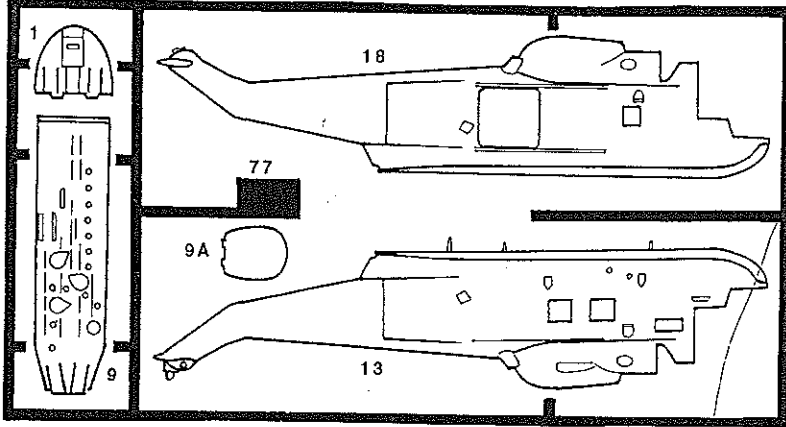

Nicht benötigte Teile
 Parts not used
 Pièces non utilisées
 Niet benötigte onderdelen
 Piezas no necesarias
 Peças não utilizadas
 Partii non usate
 Inte amândă delar
 Terpeettornat osat
 Ikke nødvendige dele
 Delar som ikke er nødvendige
 Неиспользуемые детали
 Elementy niepotrzebne
 μη χρησιμοποιούμενα εξαρτήματα
 Gereksiz parçalar
 Nepotrebné dily
 fel nem használt alkatrészek
 Nepotrební deli

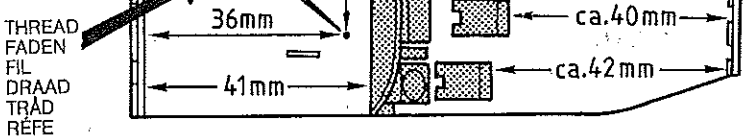
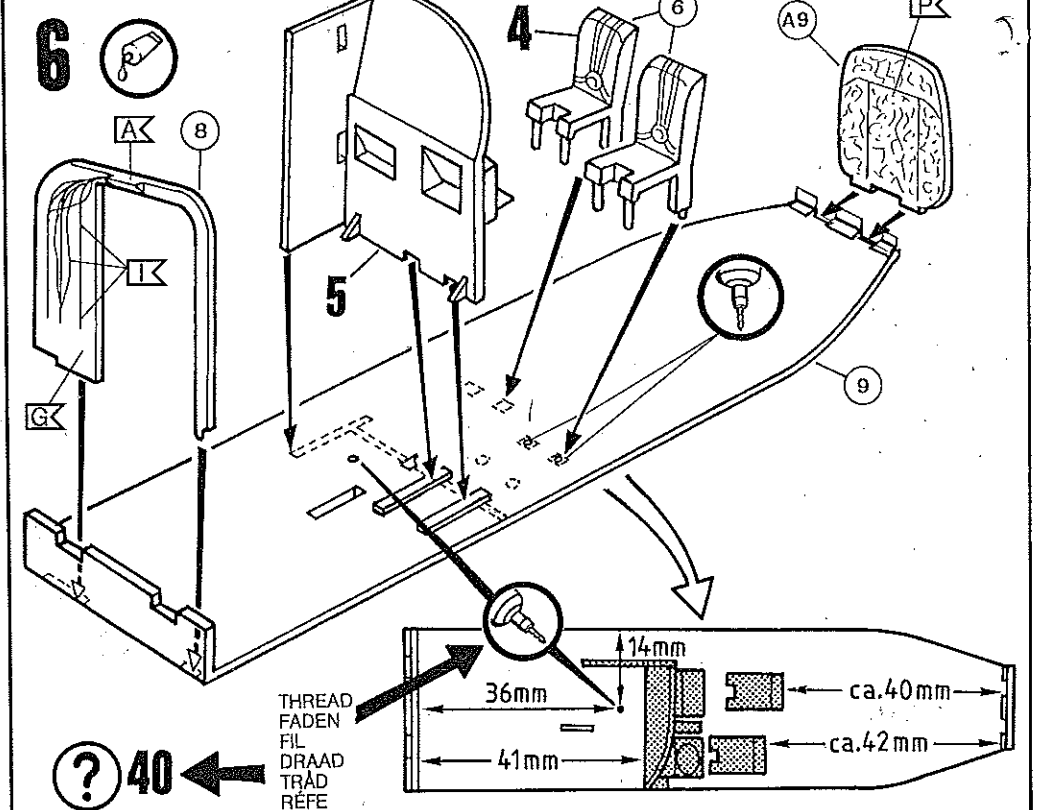
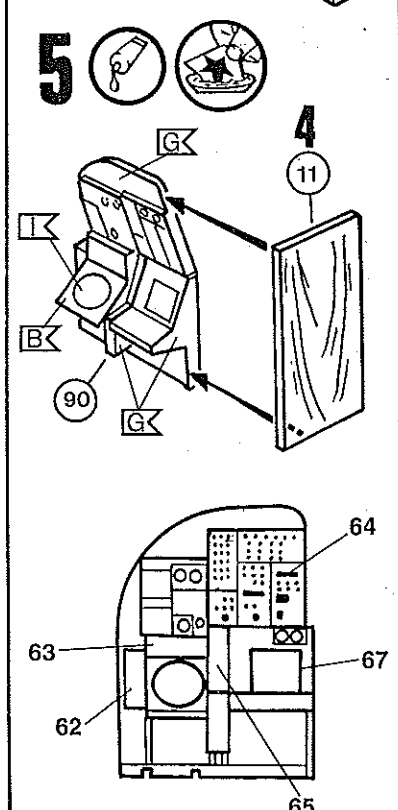
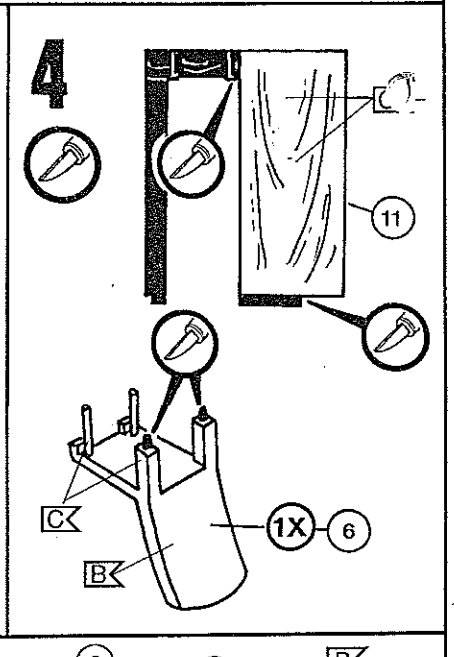
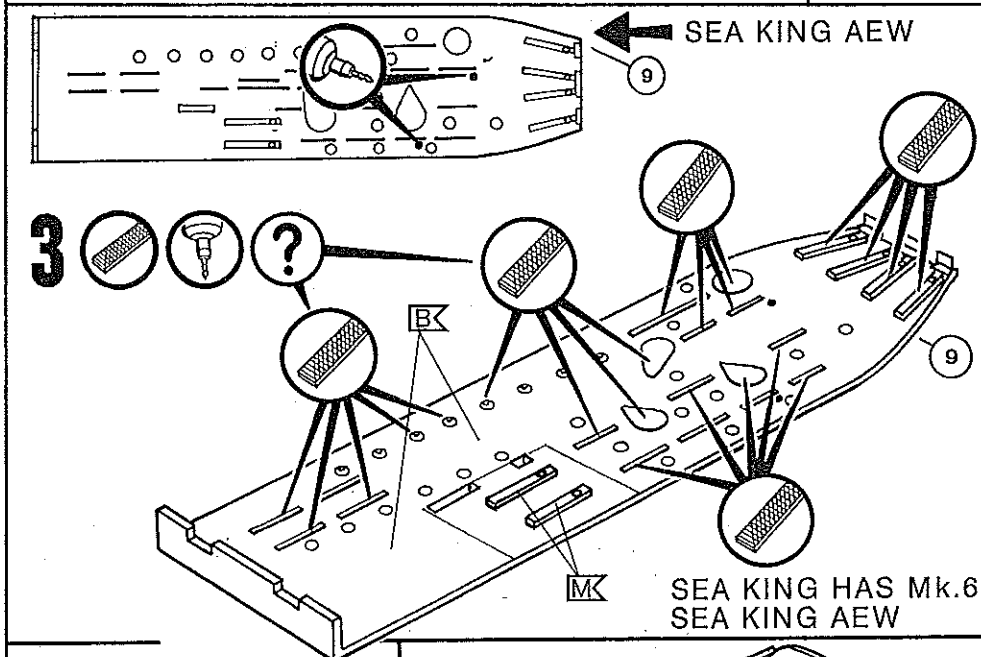
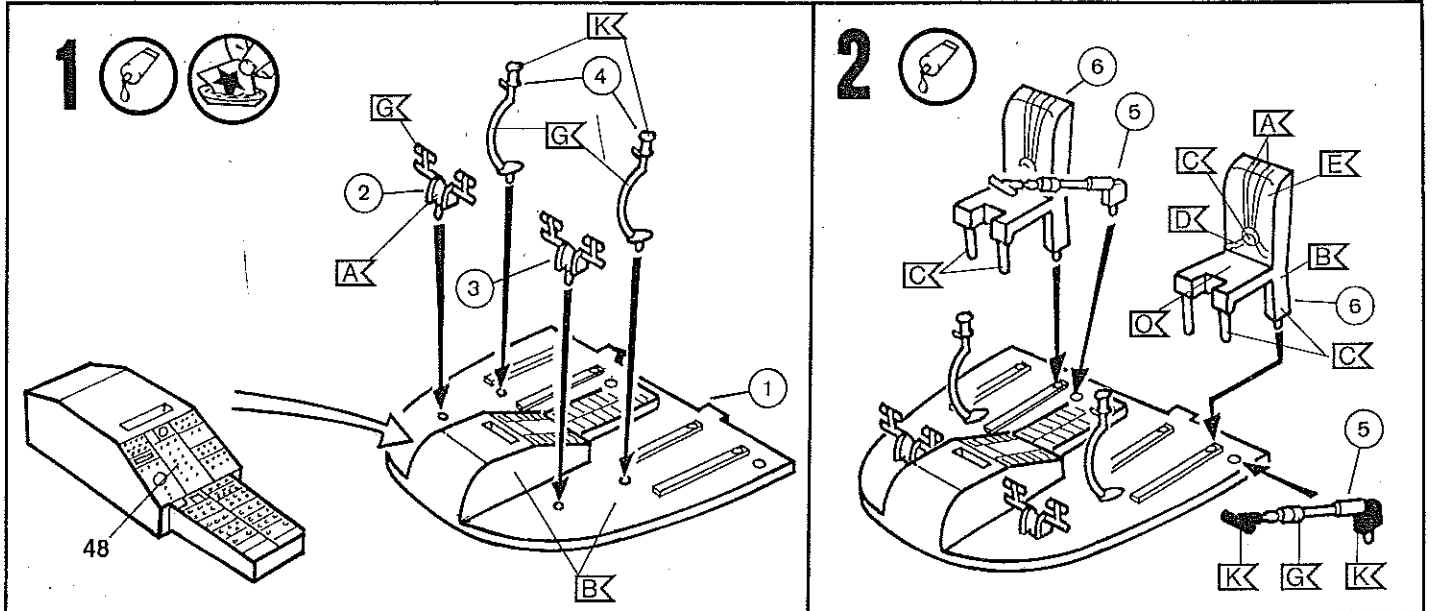

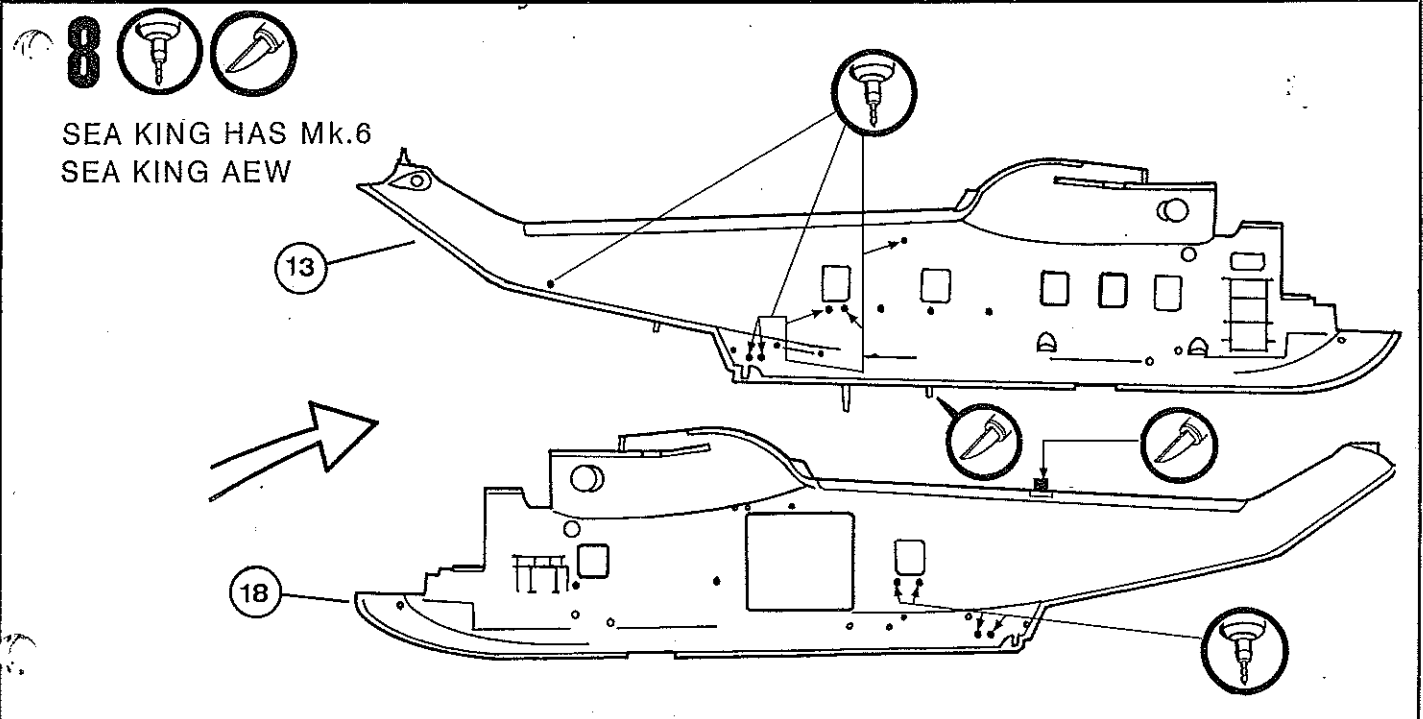
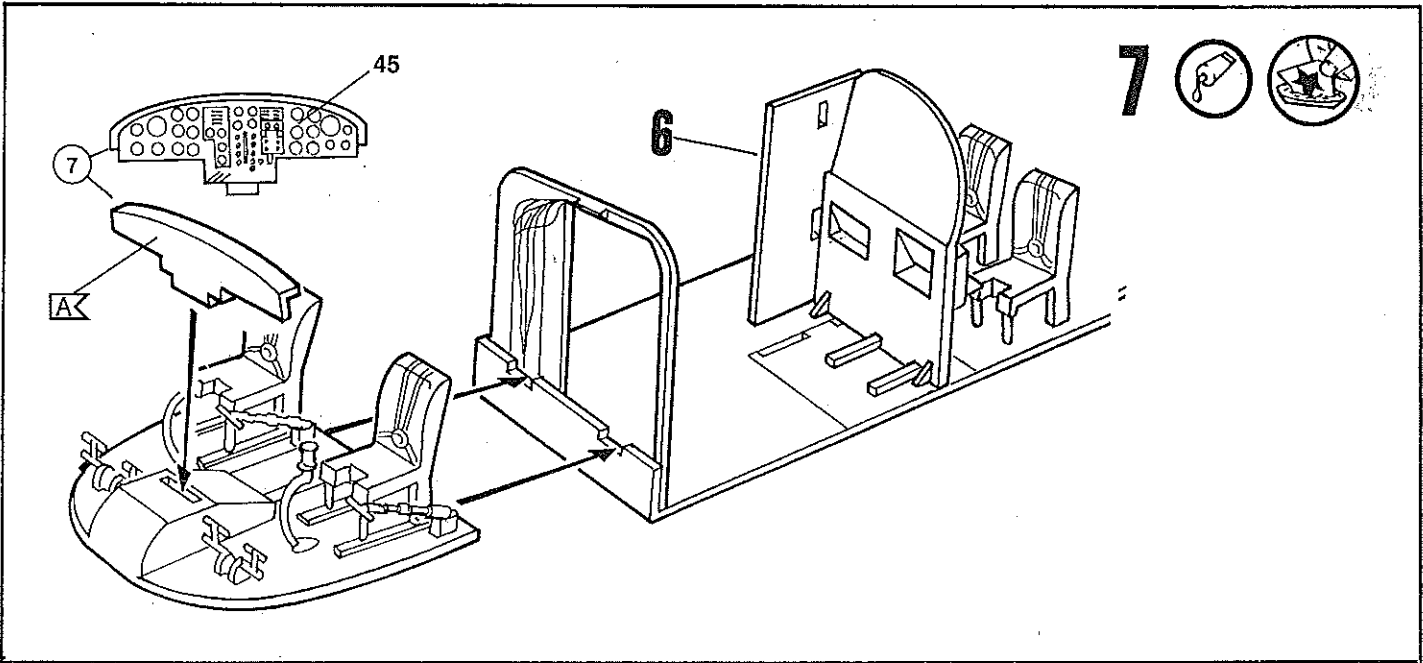

SEA KING HAS Mk.6
SEA KING AEW

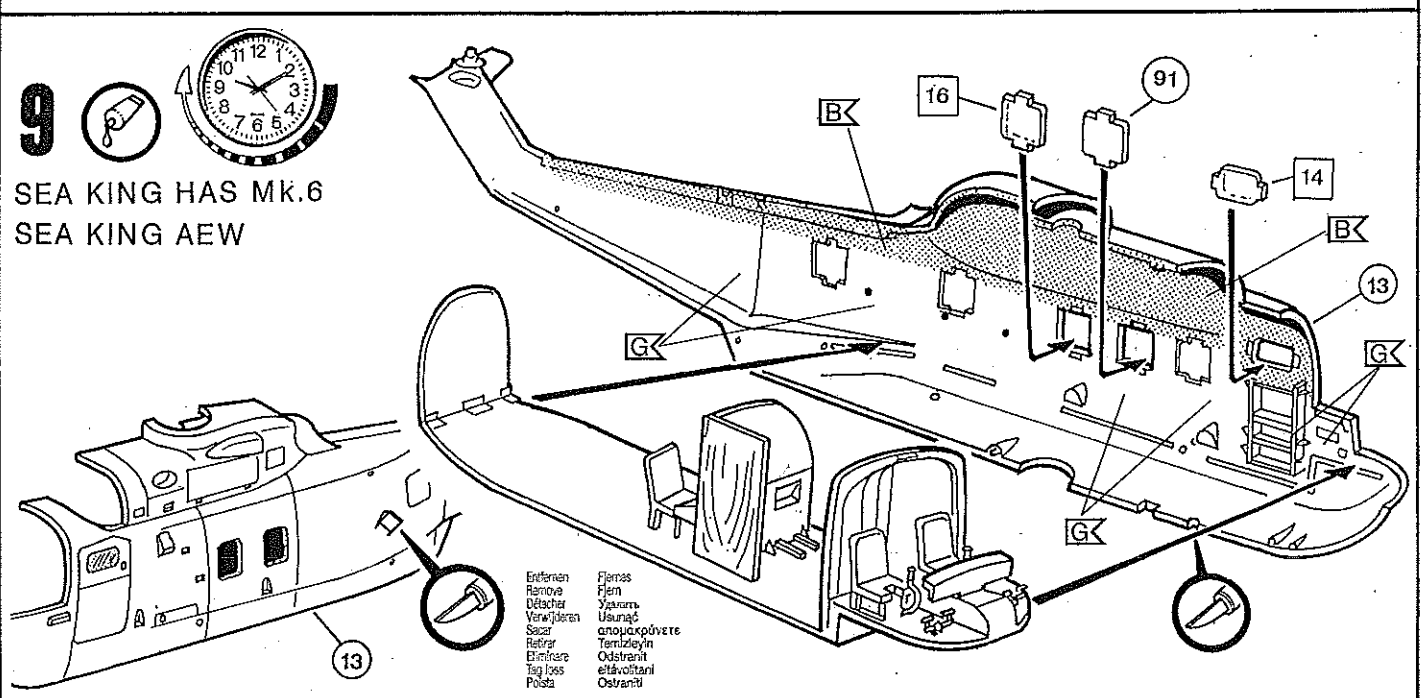

SEA KING HAS MK.6
SEA KING AEW

- | | |
|-------------|---------------|
| Entfernen | Fiornas |
| Remove | Flern |
| Détacher | Yıkamak |
| Verwijderen | Usunmaq |
| Sacar | ortopçuqovete |
| Retirar | Ternizleyin |
| Erinçire | Ostirant |
| Tag'ices | et'vostantl |
| Polsta | Ostrantl |

10

SEA KING HAS Mk.6

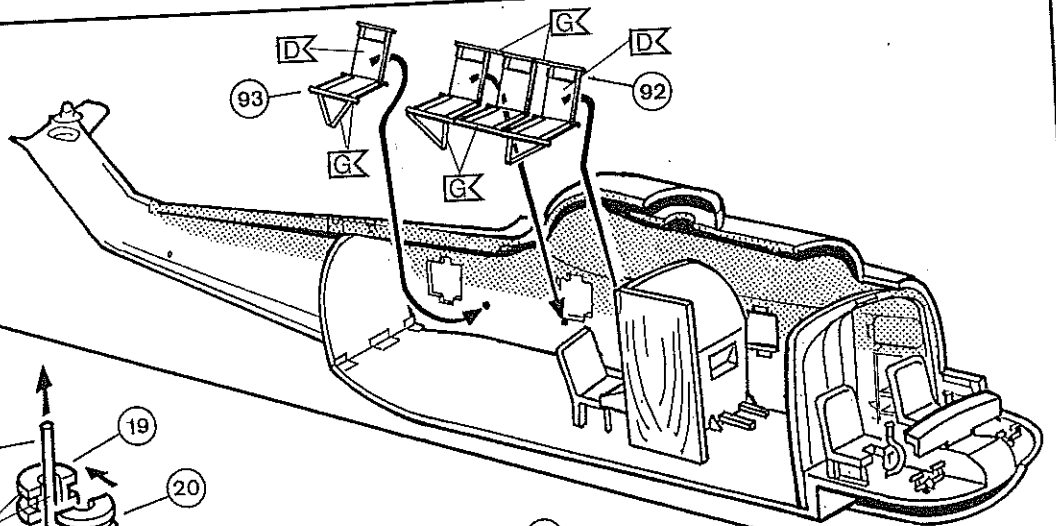

11

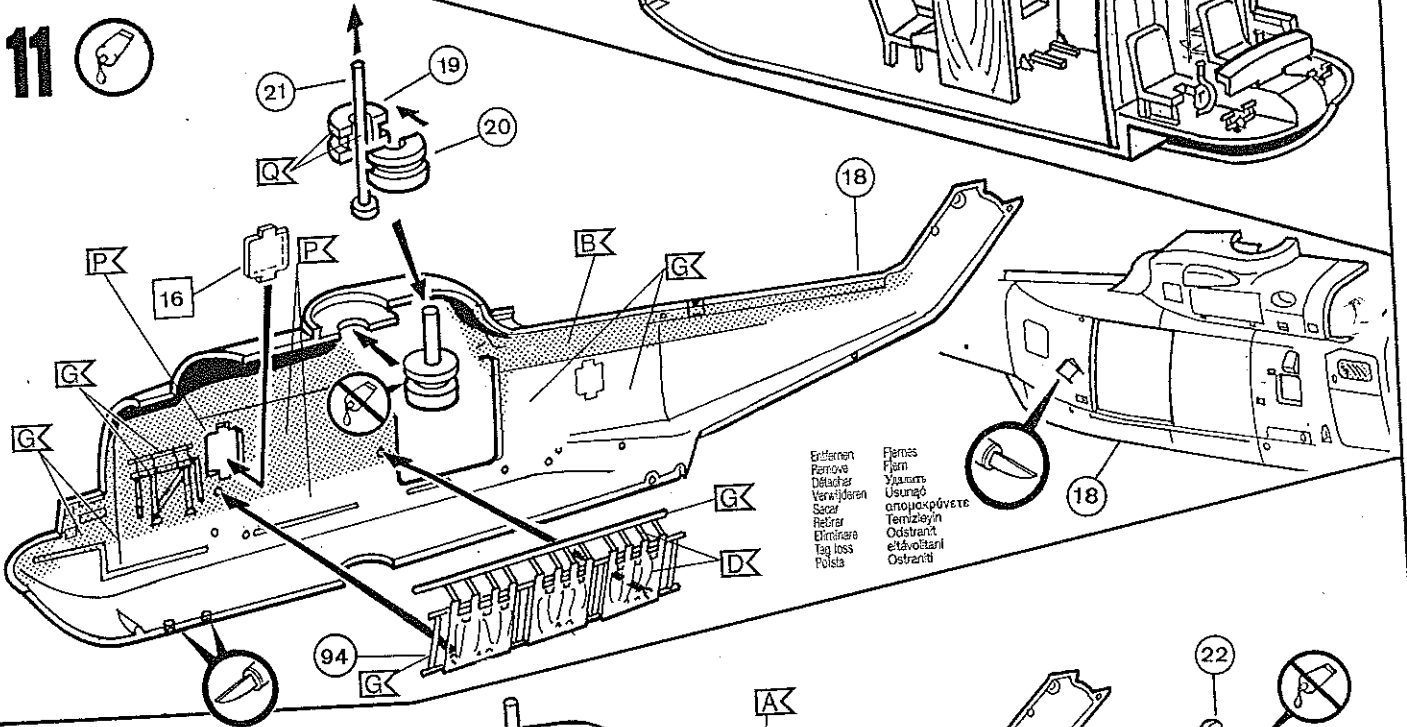

Entfernen
 Remove
 Deltachar
 Verwijderen
 Sacar
 Retirar
 Diminere
 Tag loss
 Poleta

Fijnes
 Fijn
 Yuzunq
 Usungq
 ornojokpovete
 Temizleyin
 Odstranit
 etävõitani
 Ostranit

12

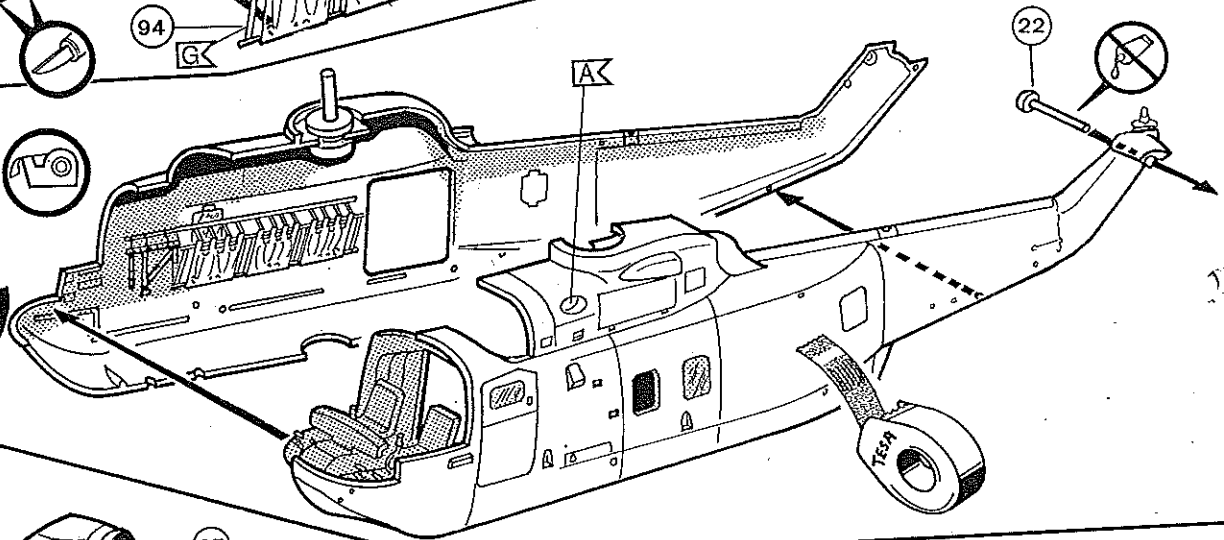
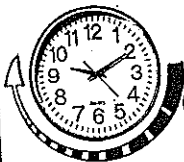

13

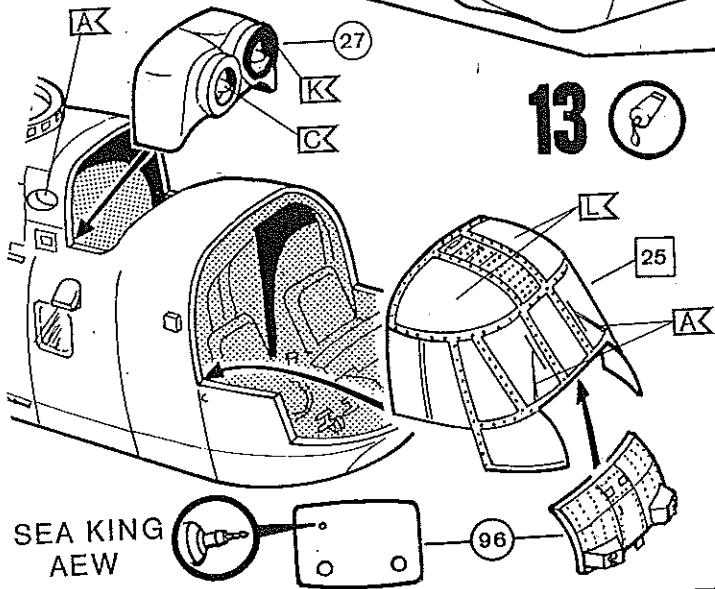

SEA KING
AEW

14

HAS - 810 Sqn.
AEW 2

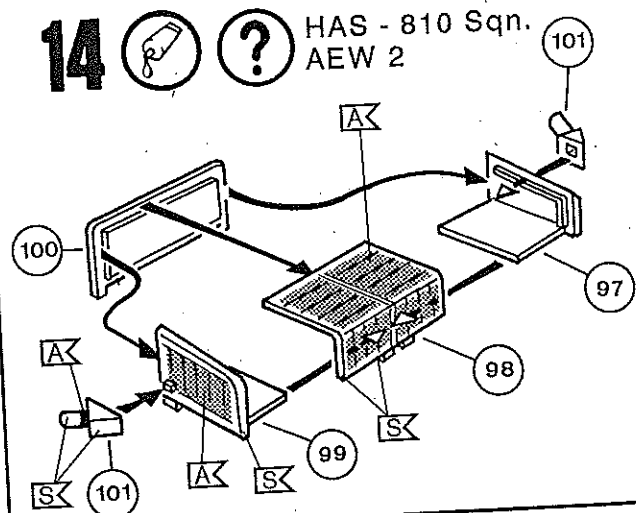

15



HAS - 810 Sqn.
AEW 2/849 Sqn.

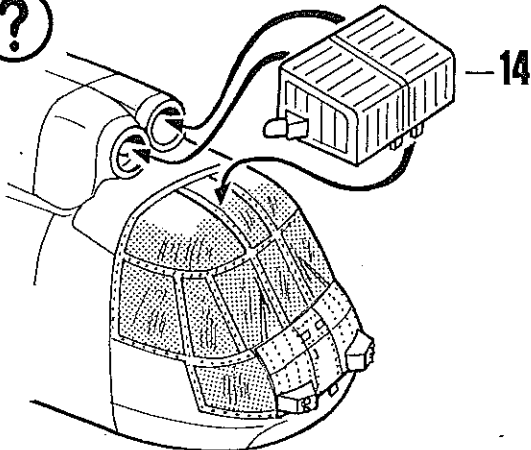

HAS - 814 Sqn.

16

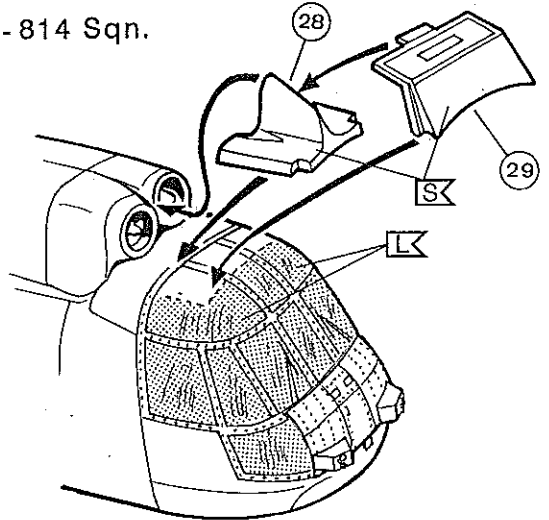

17



AK GK

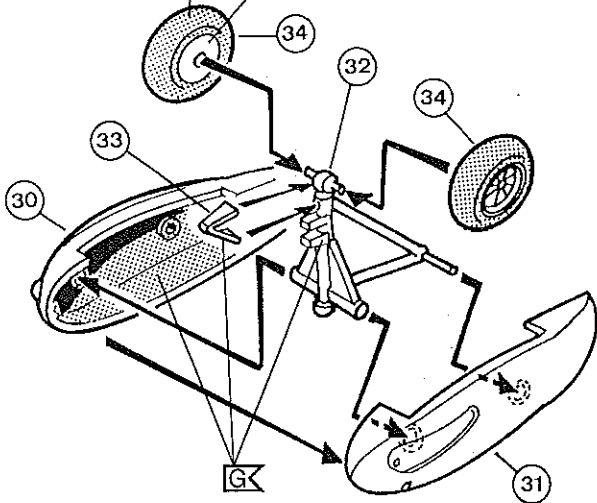

18

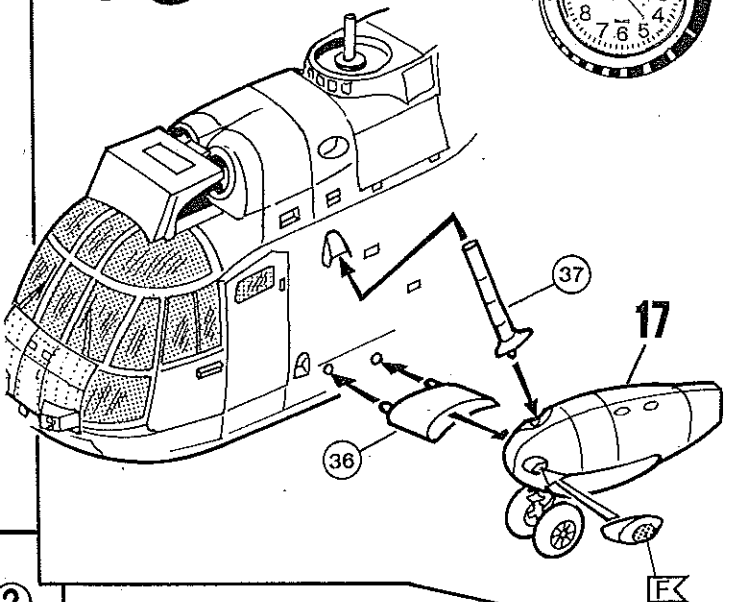

19



SEA KING HAS Mk.6 ?

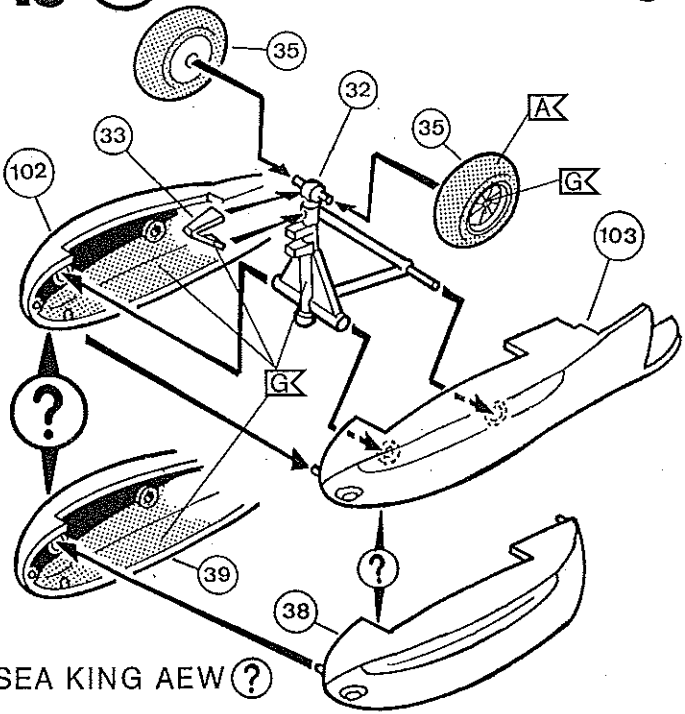

SEA KING AEW ?

20

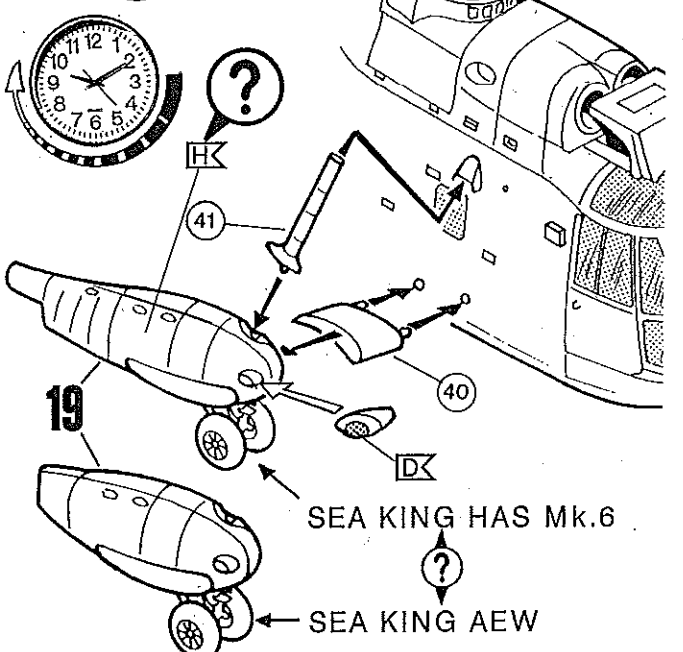

SEA KING HAS Mk.6

SEA KING AEW

21



HAS 6 - 814 Sqn.
KK + 1-6, 9-11, 13-20

↓
44

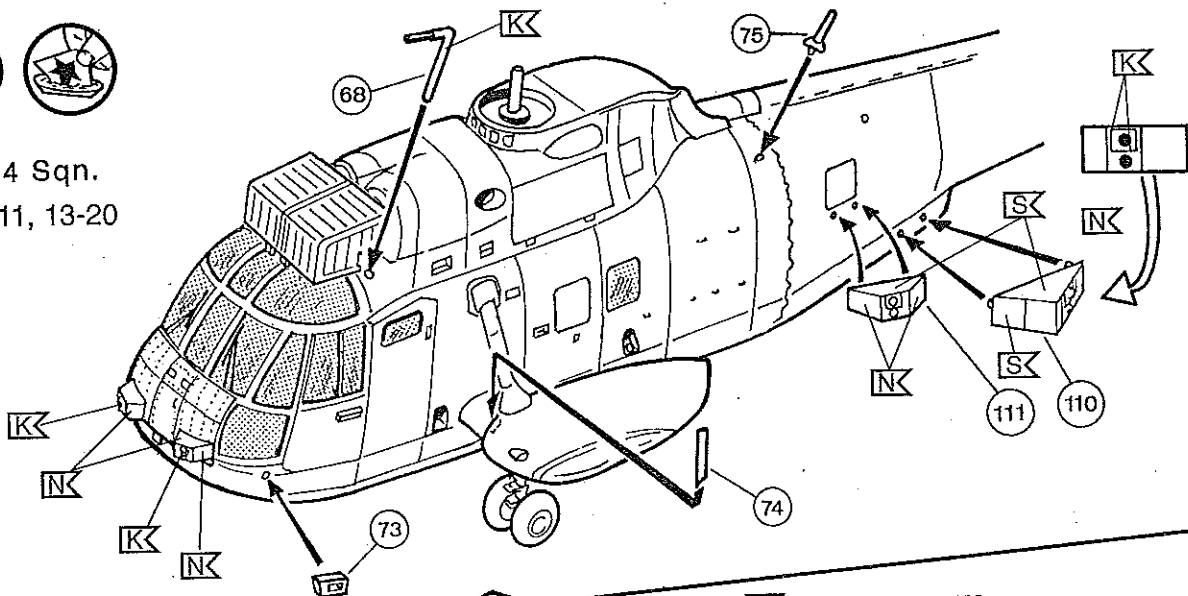

22

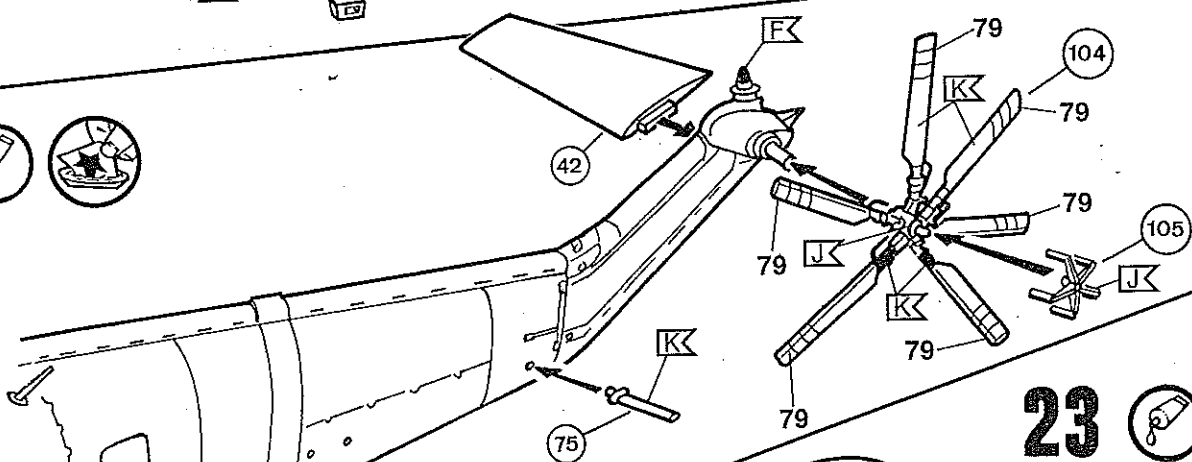

23



SEA KING AEW

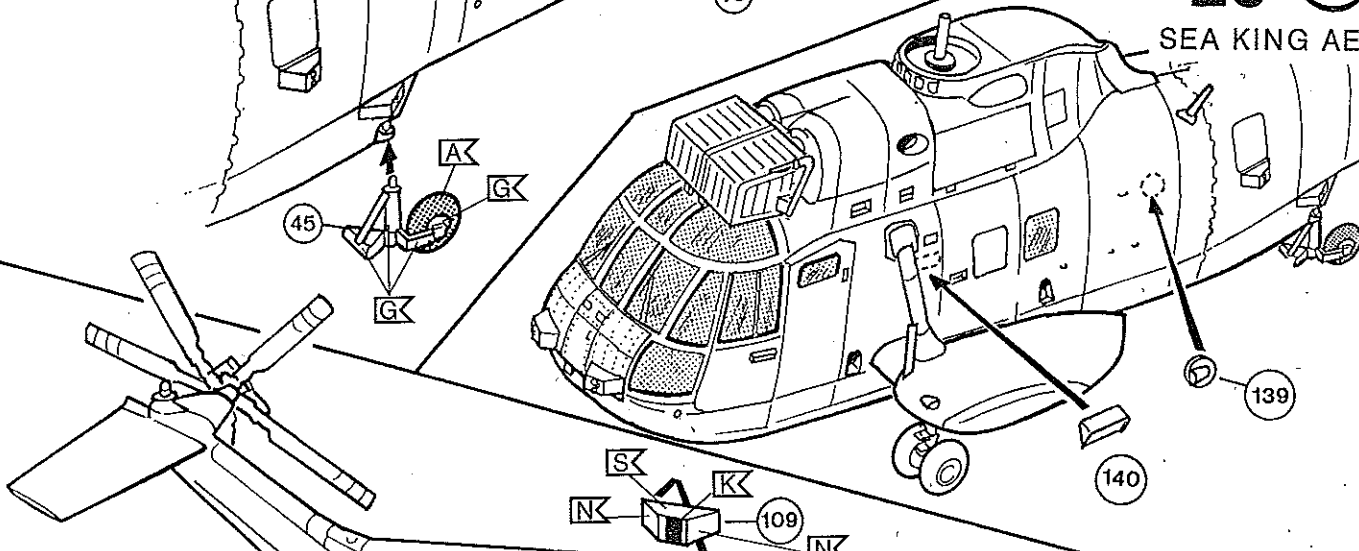

24

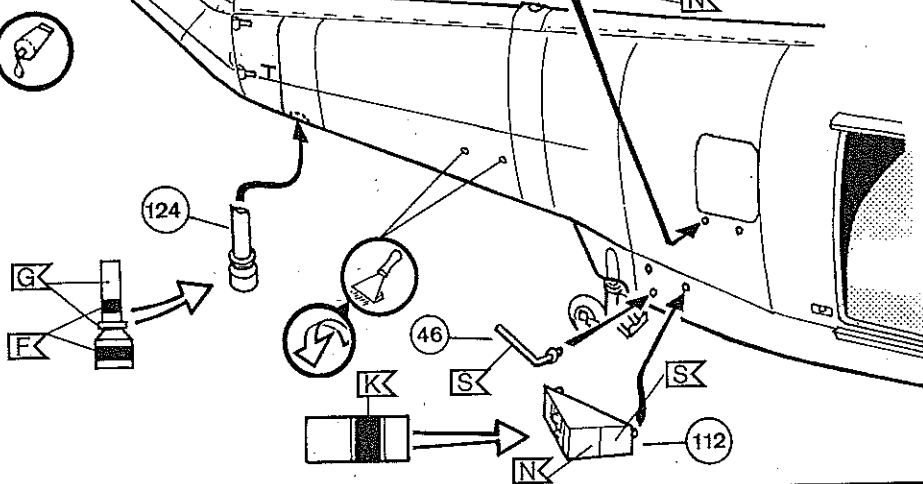

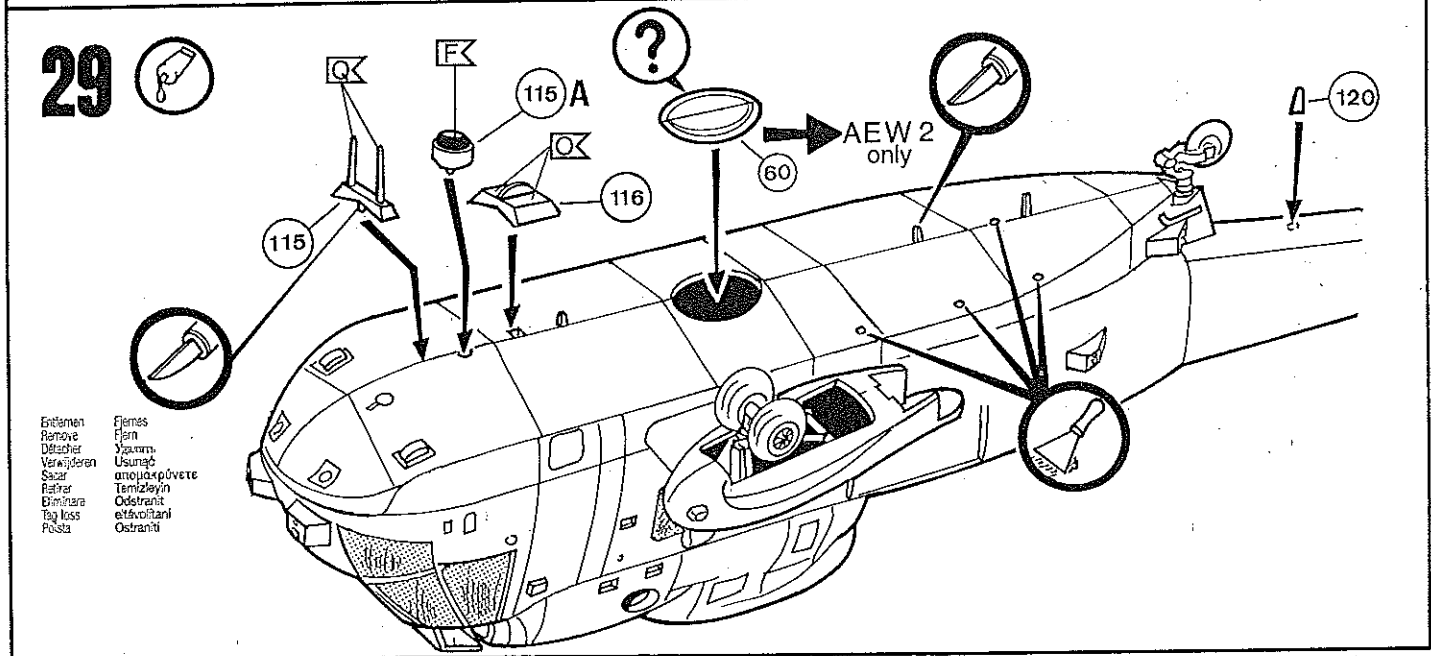
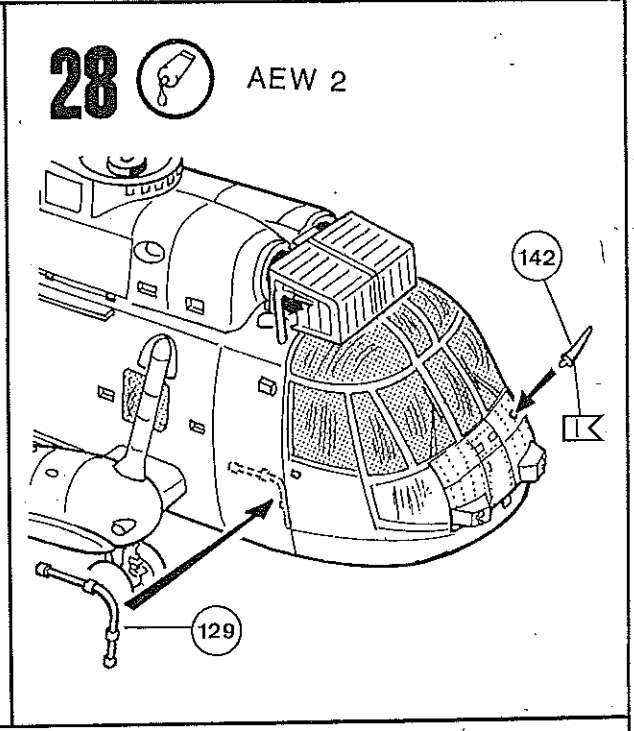
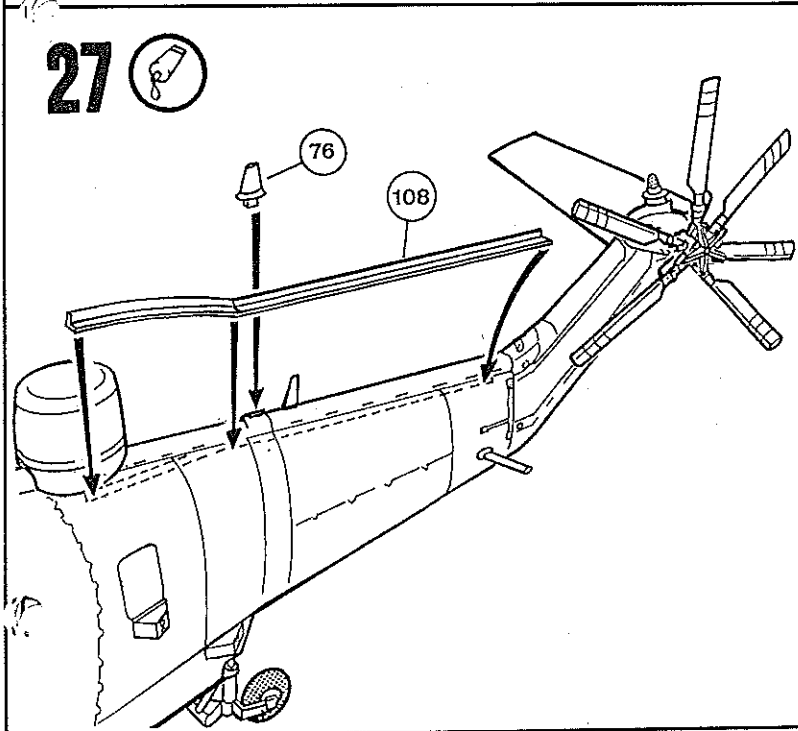
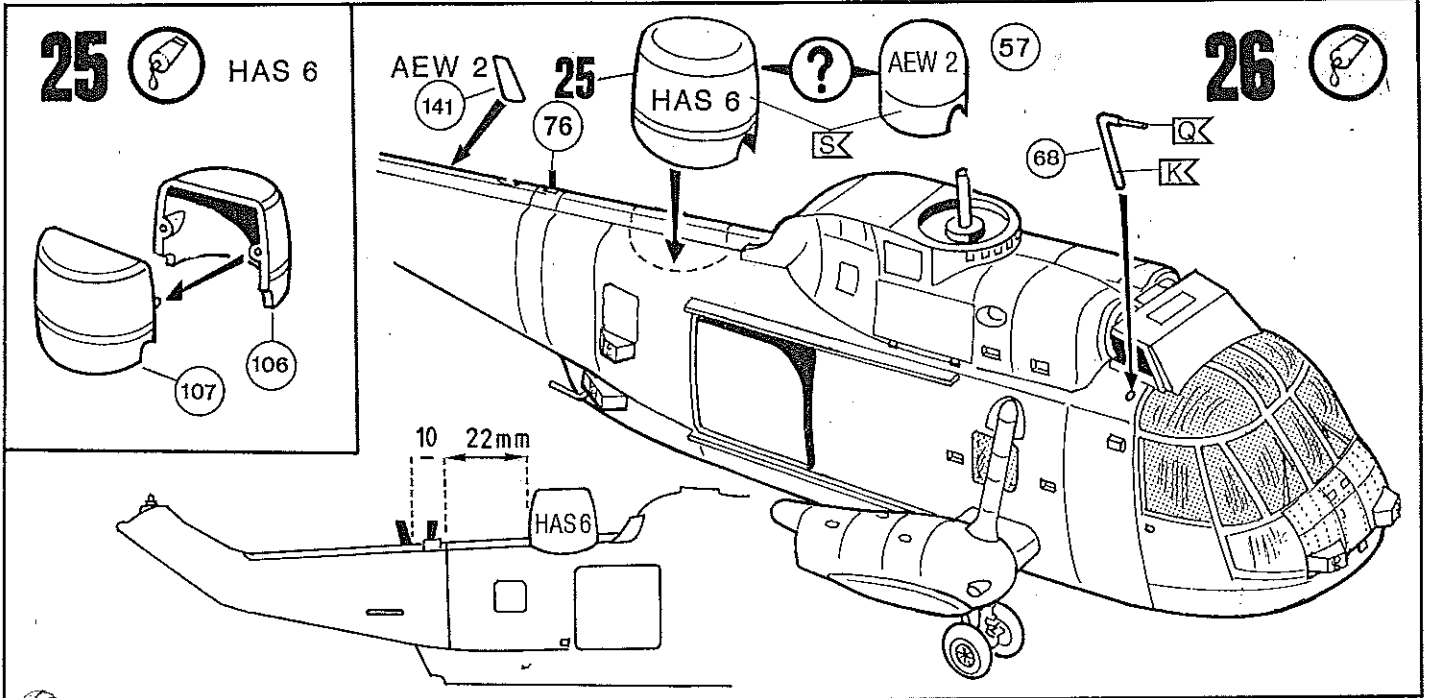

30



2X HAS 6

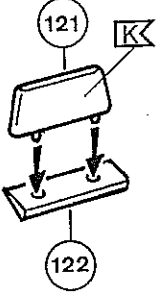

31

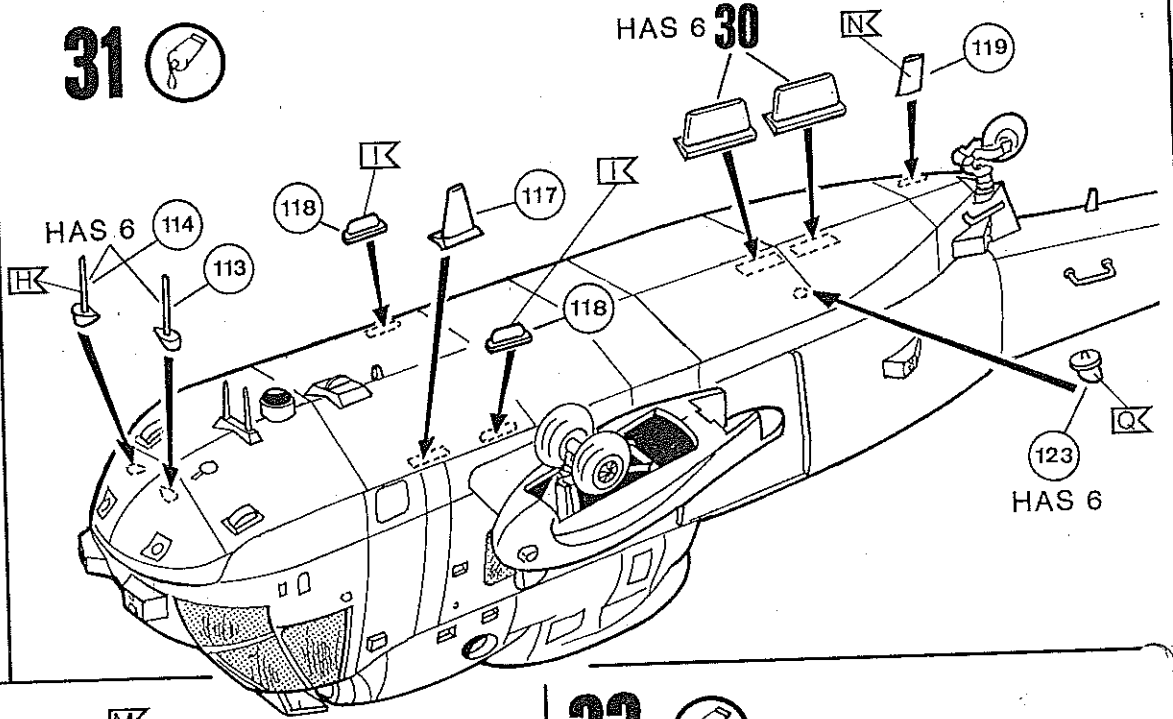

32



SEA KING AEW 2

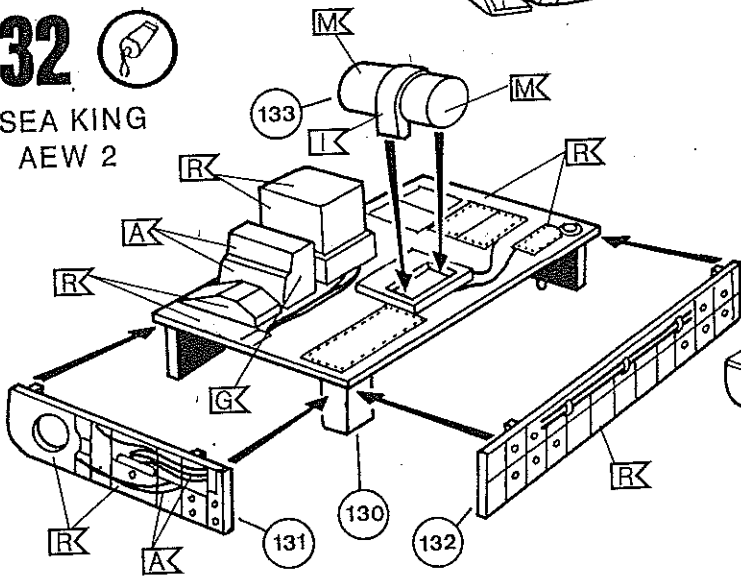

33



SEA KING AEW 2

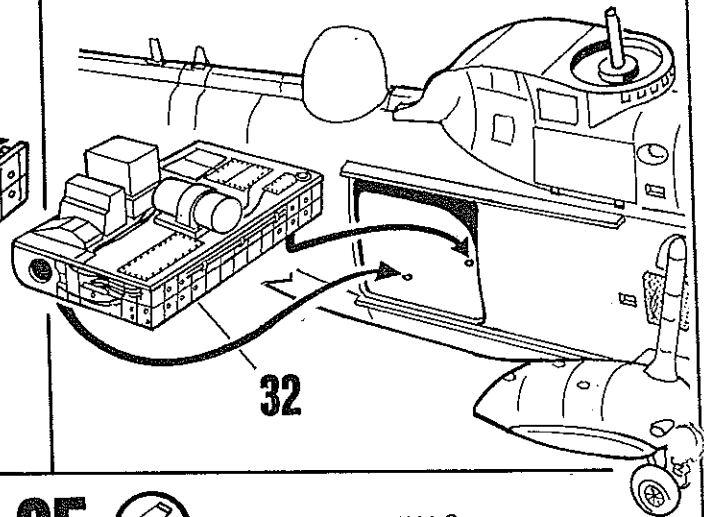

34



SEA KING AEW 2

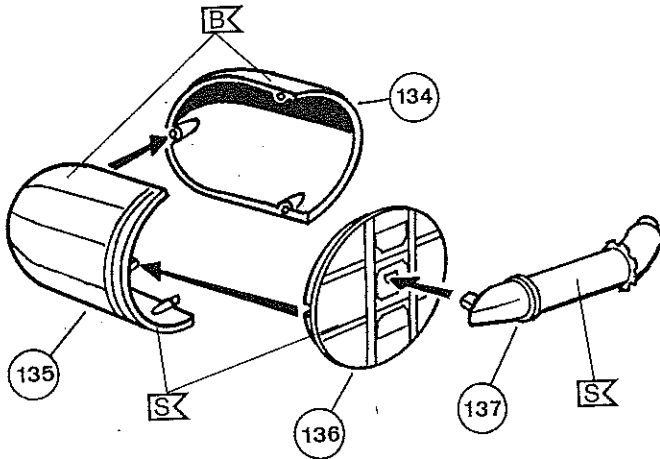

35



SEA KING AEW 2

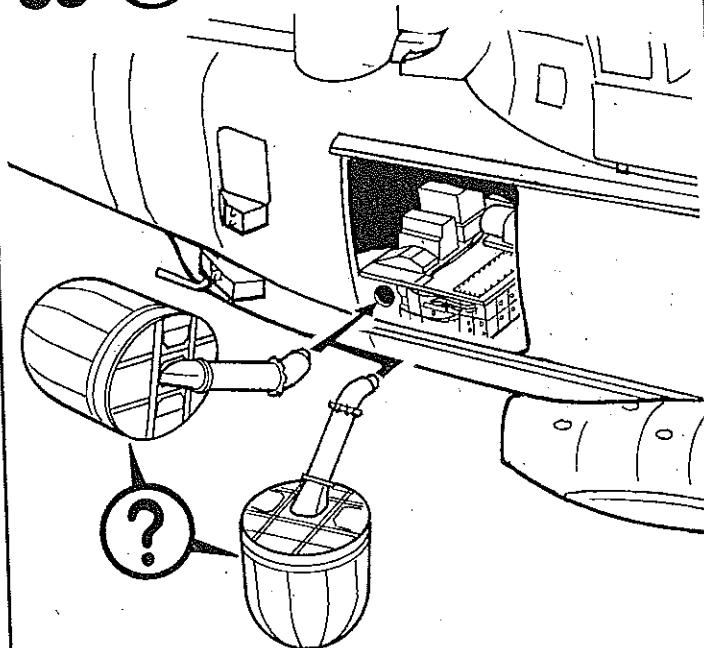

36

SEA KING AEW 2

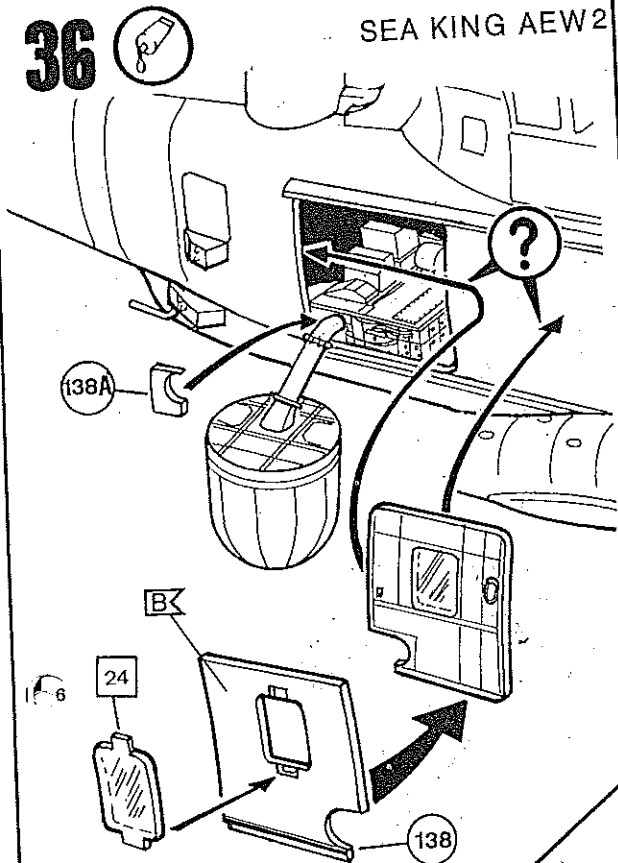

37

SEA KING HAS Mk.6

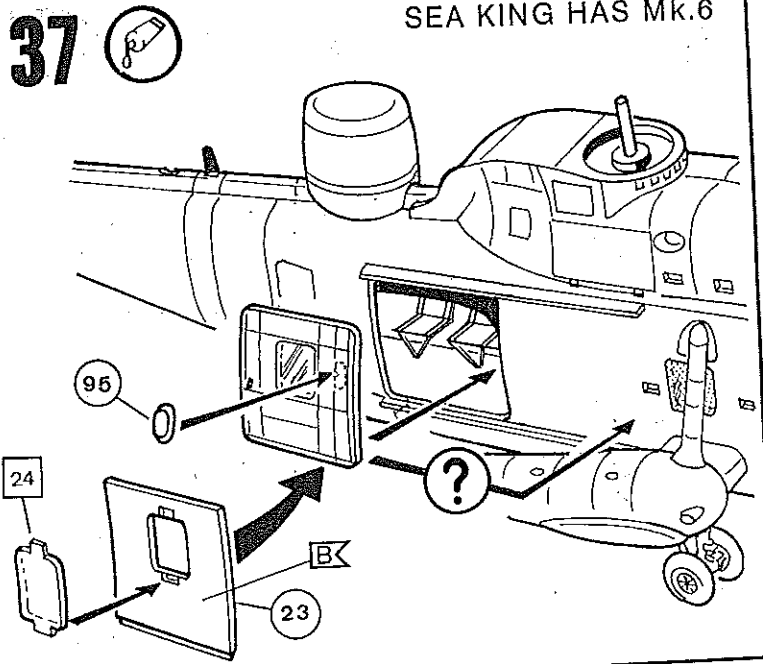

SEA KING HAS Mk.6

39

?

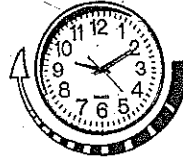
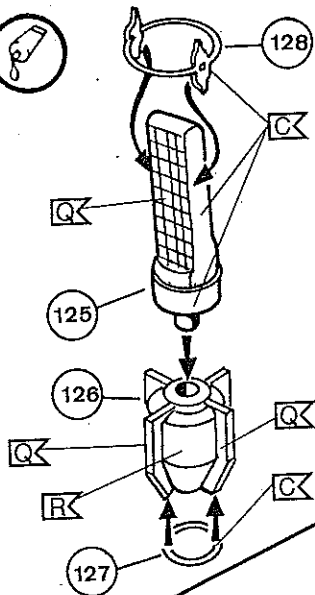

38

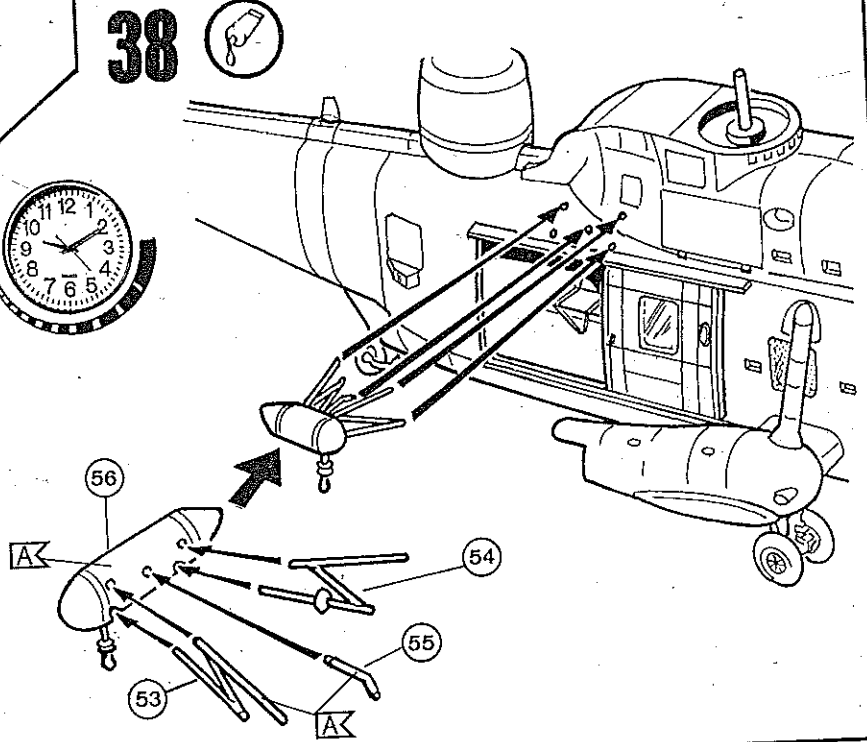

SEA KING HAS Mk.6

40

?

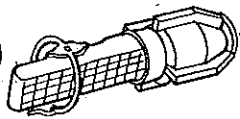

- Faden
- Thread
- Fil
- Draad
- Hilo
- Fios
- Fio
- Tred
- Lanka
- Tűt
- Szór
- Hím
- Nős
- Nős (szarvack)
- схворст
- лпшк
- Vlakno
- fonál
- Nit

Nicht enthalten
Not included
Non incluse

41

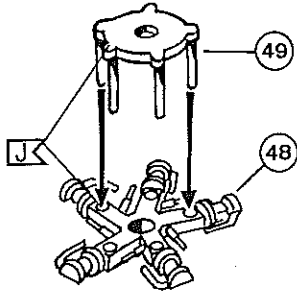

42

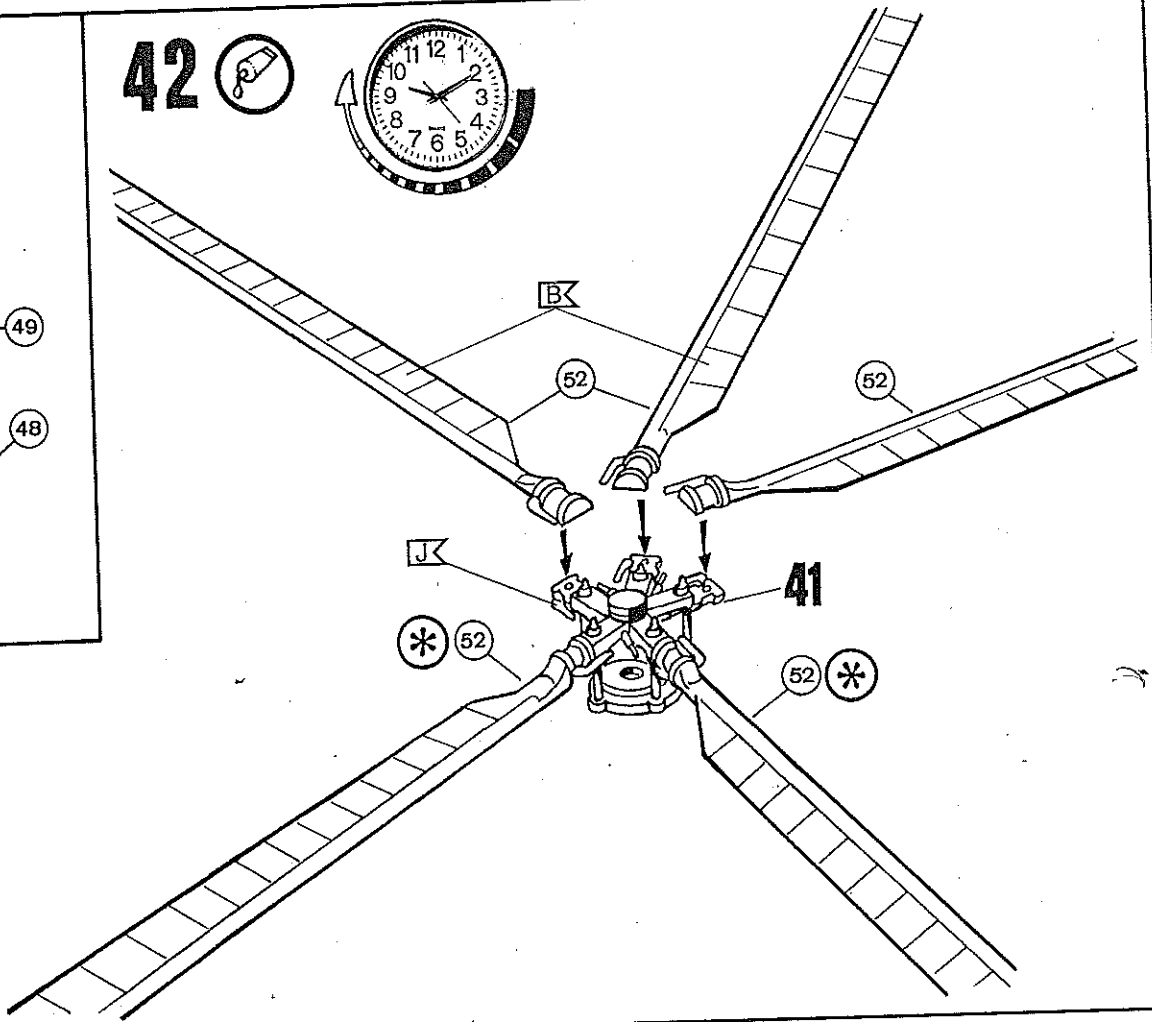
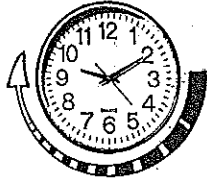

43

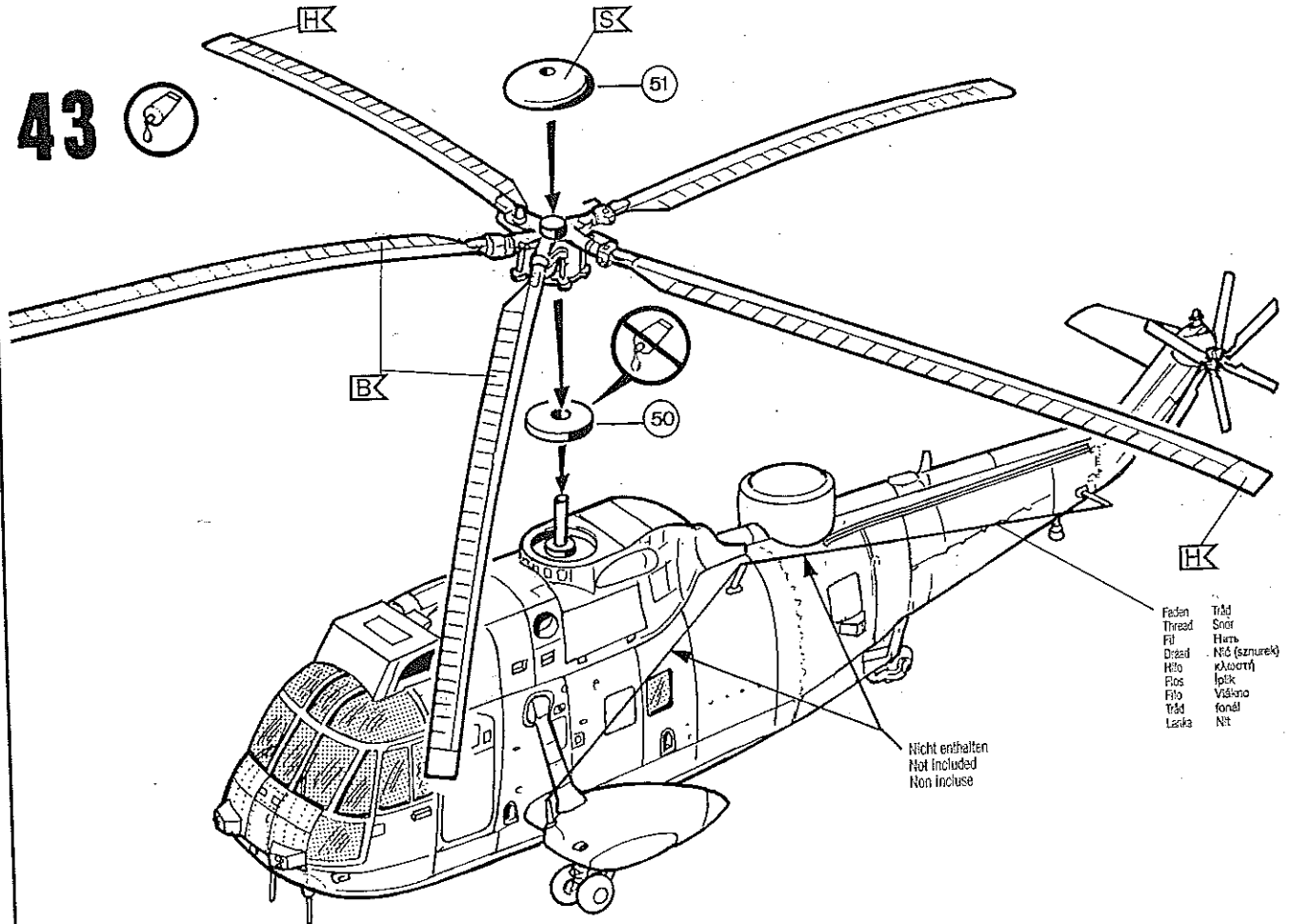

Nicht enthalten
Not included
Non include

- | | |
|--------|--------------|
| Faden | Tråd |
| Thread | Szék |
| Fil | Hír |
| Drad | N&C (szűrés) |
| Hilo | κλωστή |
| Fios | Ipik |
| Filo | Vidano |
| Tråd | fonál |
| Lanka | Nit |

44



Version A

Sea King HAS6, No.814 Squadron, Fleet Air Arm,
RFA Argus & RNAS Culdrose, 1999.

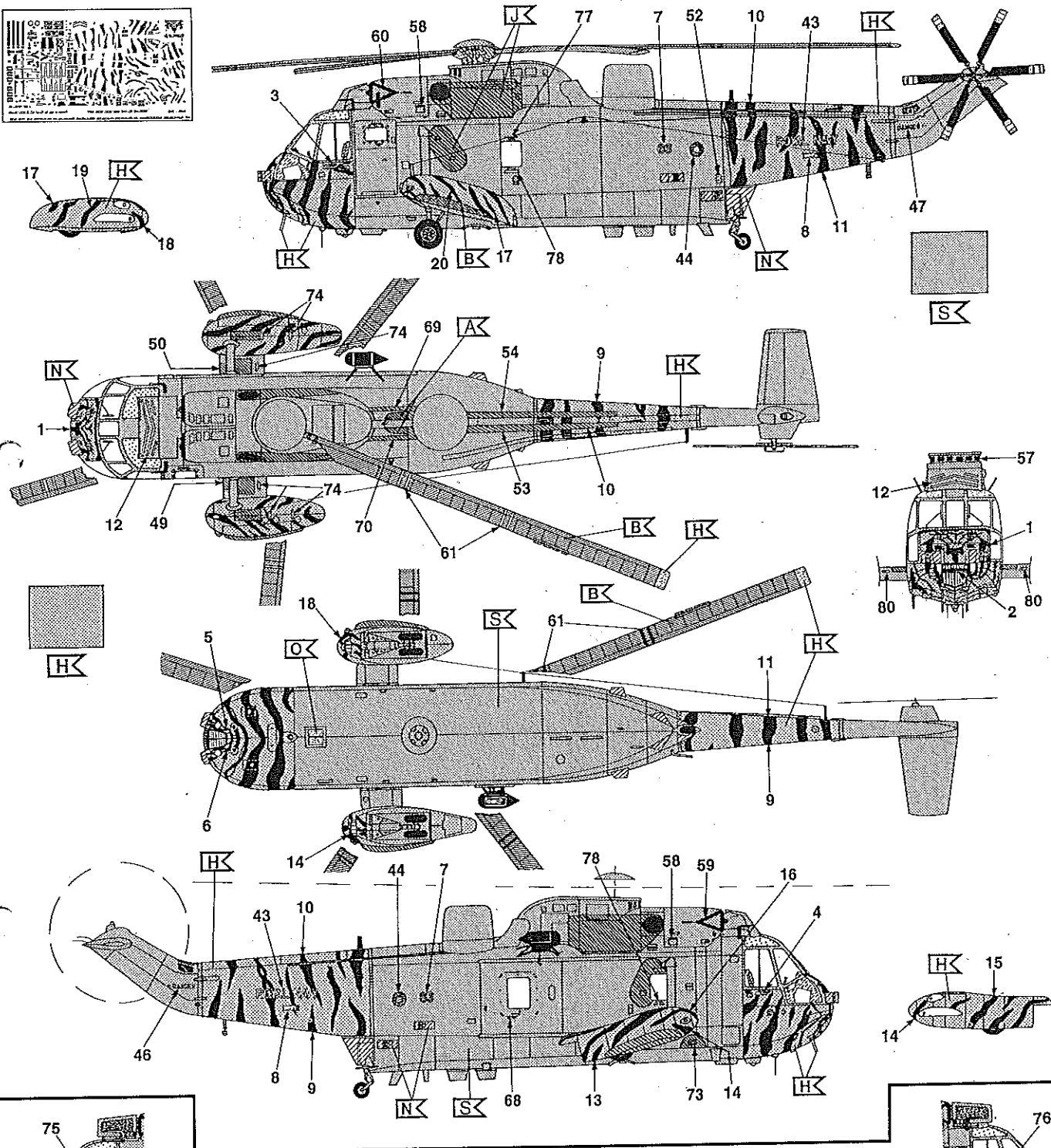
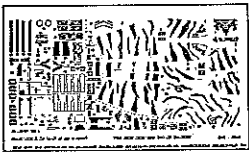

Version B

Sea King HAS6, No.810 Squadron,
'B' Flight, Fleet Air Arm, HMS
Campbelltown & RNAS Culdrose, 2000.

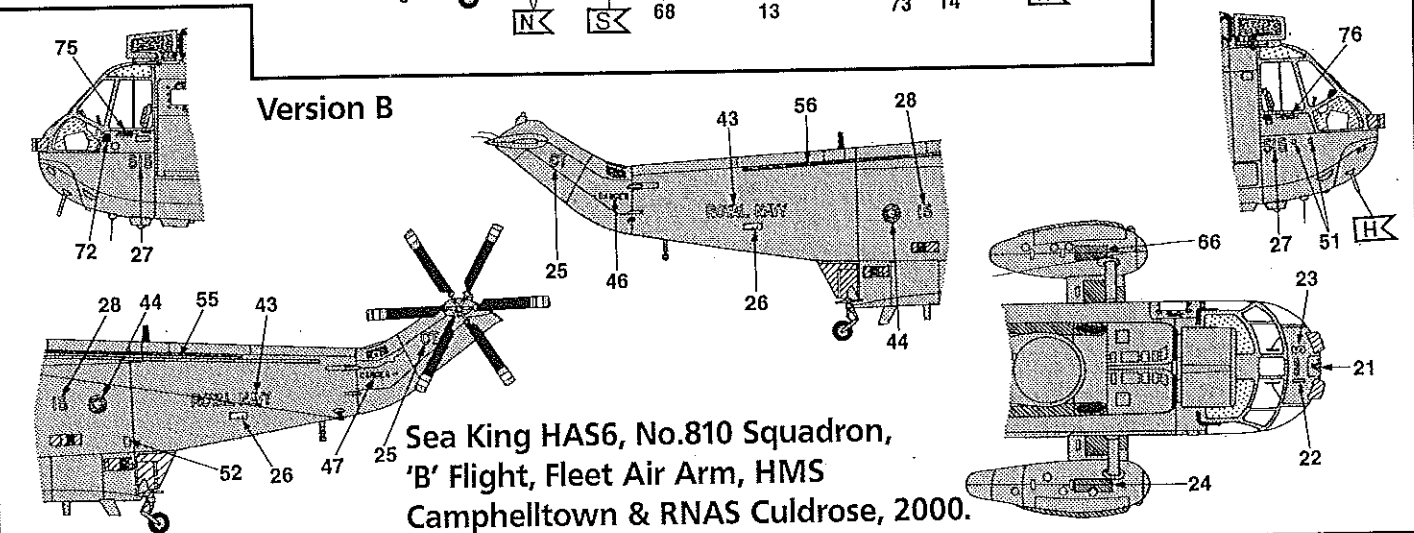

45



Sea King AEW 2, No.849 Squadron, 'B' Flight, HMS Illustrious & RNAS Culdrose, 2000.

Version C

