



VW NEW BEETLE (with Tuning Version)

07394 - 0389

©2002 BY REVELL AG.

PRINTED IN GERMANY



VW NEW BEETLE (mit Tuner Version)

Die Anfang der 90er Jahre entwickelte Designstudie "Concept 1" wurde 1994 auf der Motorshow in Detroit vorgestellt. Im März 1998 erfolgte die Auslieferung des Serienfahrzeugs in den USA, seit Herbst des gleichen Jahres wird er mit nicht minder positiven Ergebnissen in Europa verkauft. Nur noch äußerlich gleicht der 4092 mm lange Beetle seinem Urahn, dem VW Käfer. Seine Silhouette prägt die moderne Form, die vortrefflich das harmonische Zusammenspiel von sanften Linien und ansprechenden Wölbungen zum Ausdruck bringt. Das ansprechende Design setzt sich in den eingelassenen Front- und Heckleuchten fort, auch das Interieur wartet mit hochwertigen Kunststoffen und Textilien auf. Der New Beetle verfügt über Frontantrieb und einen Vierzylinder-Motor, der wahlweise als Benzinmotor mit 115 PS oder Turbodieselmotor mit 90 PS bestellt werden kann.

Die solide Bauweise, das originelle Design, modernste Technik und exzellente Qualität beschert dem New Beetle eine große Anhängerschaft und ließ ihn sehr schnell zu einem der populärsten modernen Autos auf der Straße werden. So ist es nur natürlich, dass sich auch die Tuning Szene für den Wagen interessiert, die sich in den letzten Jahren, insbesondere in den USA, zusehends dem Bereich Sport Compact widmet. Eine Vielzahl an New Beetles bekamen die komplette Tunerausstattung, nachdem sie beim VW Händler vom Hof gerollt waren. Die einzigartige Karosseriegestaltung des New Beetle ist geradezu prädestiniert für Änderungen, und viele moderne Firmen des Zubehörmarktes produzieren eine ganze Palette von hochtechnischen Motorzusatzteilen, ändern die Räder nach Kundenwunsch, verbessern die Aufhängung, liefern Karosseriebausätze und verkleiden Teile, die speziell für den neuen Beetle gemacht wurden.

Der Revell Bausatz kann - laut Bauanleitung oder wie gewünscht - wahlweise als Tuning Ausführung mit entsprechenden Teilen wie niedrigerer Radaufhängung, Seitenschwellern, Front- und Heckspoiler, Metalauspuffrohrspitze und entsprechendem Abziehbild oder als normales Serienfahrzeug gebaut werden.

VW NEW BEETLE (with Tuner version)

The Concept I design study developed at the beginning of the nineties was exhibited in 1994 at the Detroit Motor Show. In March 1998 production cars were delivered in the USA and from the autumn of the same year it was sold in Europe with no less positive results. The 4.09 m long Beetle bears only an external resemblance to its predecessor the VW Beetle. Its silhouette is characterised by a modern form that harmoniously coordinates the interplay of soft lines with pleasant curves. This attractive design is carried through into the inset front and rear lights and the interior with its quality synthetics and fabrics. The New Beetle has front-wheel drive and a 4-cylinder engine, that can be ordered as a 115 hp petrol engine or a 90 hp turbodiesel.

The robust construction, original design, latest technology and excellent quality of the New Beetle attracted a great following and it very quickly became one of the most popular modern cars on the road. So it is only natural that the tuning scene should show an interest in this car that, over the past few years, particularly in the USA, has come to the fore in the sports compact class. A great number of New Beetles were given the complete tuner kit, after they rolled off the premises of the VW dealers. The unique body-shape of the New Beetle is practically predestined for alterations and many modern accessory manufacturers produce a whole range of high-tech add-ons. They alter the wheels to customer requirements, improve the suspension, supply body kits and trim parts that are specially made for the New Beetle. The Revell model kit can be built in accordance with the instructions or as the tuner version with optional parts such as low wheel suspension, side sills, front and rear spoilers, metal exhaust pipe ends and appropriate decals or as the standard production model.

Form hergestellt und im Eigentum von Revell AG/Revell Monogram Inc. Widerrechtliche Nachahmungen werden gerichtlich verfolgt.
Ce produit est propriété de la société Revell AG/Revell Monogram Inc. Toute utilisation ou duplication frauduleuse fera l'objet de poursuites en justice.

Modelado y en propiedad de Revell AG/Revell Monogram Inc. Imitaciones ilícitas serán perseguidas por la ley.

Forma prodotta dalla Revell AG/Revell Monogram Inc. e di proprietà della stessa impresa, la quale procederà legalmente contro ogni imitazione abusiva.

Malli on Revell AG/Revell Monogram Inc. valmistama ja omaisuutta. Laittomaan kopiointiin tuliaan puuttumaan oikeudellisiin toimin.

Formen er produsert og eies av Revell AG/Revell Monogram Inc. Etterligning uten tillatelse vil bli gjenstand for rettslig forfølgelse.

Produkcja i prawa własności firmy Revell AG/Revell Monogram Inc. Nielegalne podrobienie jest zabronione pod odpowiedzialnością sądową.

Model, Revell AG/Revell Monogram Inc. firmasının mülkiyeti altında imal edilmiştir. Kanunna aykırı taklitler mahkemeye takip edilecektir.

A forma előállításja és a tulajdonjog birtokosa a Revell AG/Revell Monogram Inc. A jogellenes utánzatokat és hamisítványokat bíróságilag üldözik.

Mould manufactured by and property of Revell AG/Revell Monogram Inc. Illegal imitations are subject to prosecution.

Vorm vervaardigd door en eigendom van Revell AG/Revell Monogram Inc. Onrechtmatige nabootsingen worden gerechtelijk vervolgd.

Formas produzidas e de propriedade da Revell SA/Revell Monogram Inc. Cópias não autorizadas serão processadas juridicamente como determinado na lei.

Modellen tillverkad av och tillhör Revell AG/Revell Monogram Inc. All kopiering beivras enligt lagen om upphovsrätt.

Formen er fremstillet af Revell AG/Revell Monogram Inc. som også har ejendomsret. Lovstridige efterligninger søgges.

Модель изготовлена и является собственностью фирмы Revell AG/Revell Monogram Inc. Проникновенные подделки преследуются в судебном порядке.

Η μορφή κατασκευάστηκε και περιήλθε στην ιδιοκτησία της Revell AG/Revell Monogram Inc. Οι παράνομες αντιγραφές θα καταδικαστούν δικαστικά.

Tvár byl vytvořen firmou Revell AG/Revell Monogram Inc. a je jejím vlastnictvím. Proti nezákonným napodobením se bude postupovat soudní cestou.

Forma je proizvedena in je vlasništvo Revell AG/Revell Monogram Inc. Neovlašene kopije bodo pravno kaznjene.

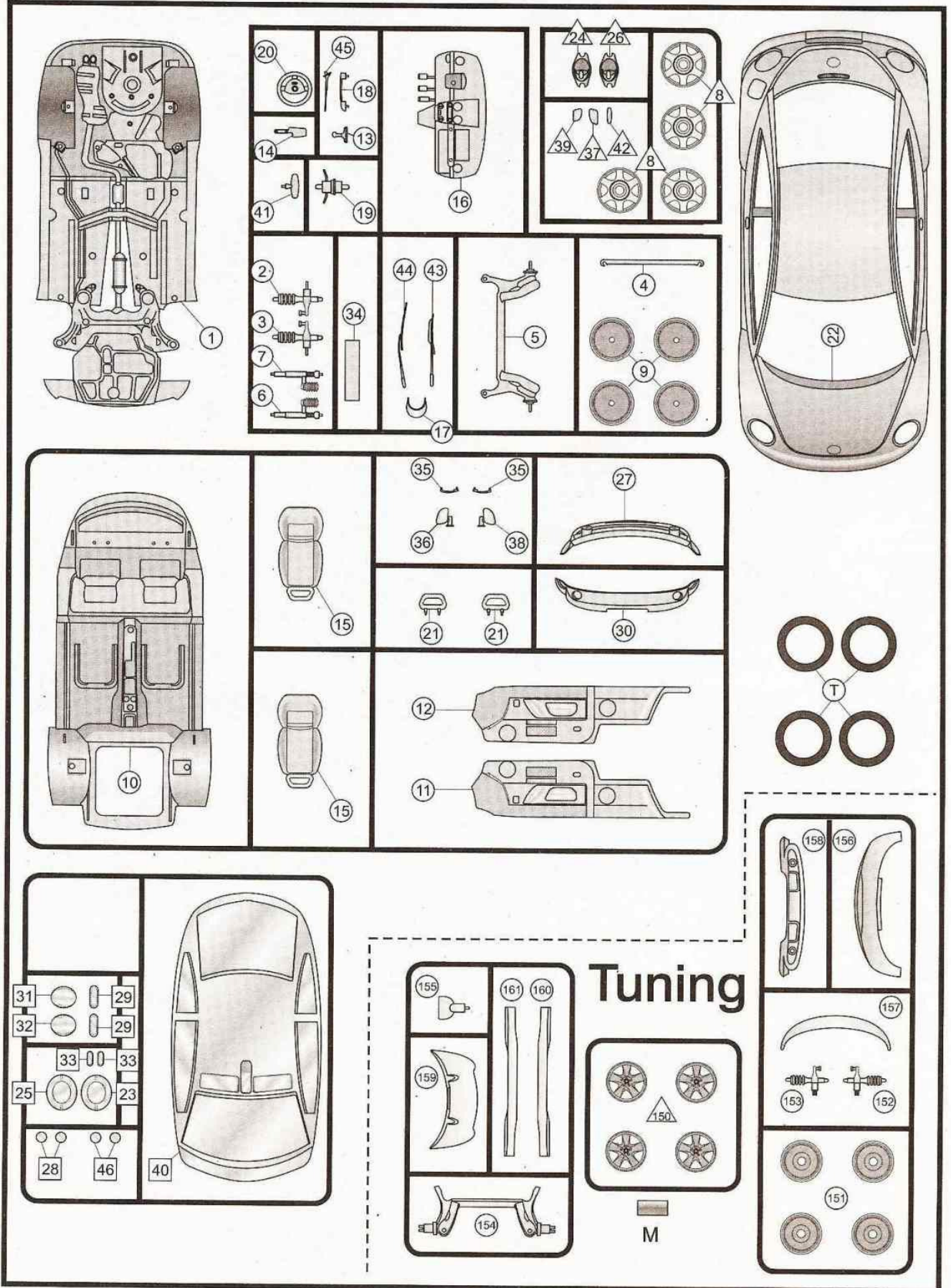

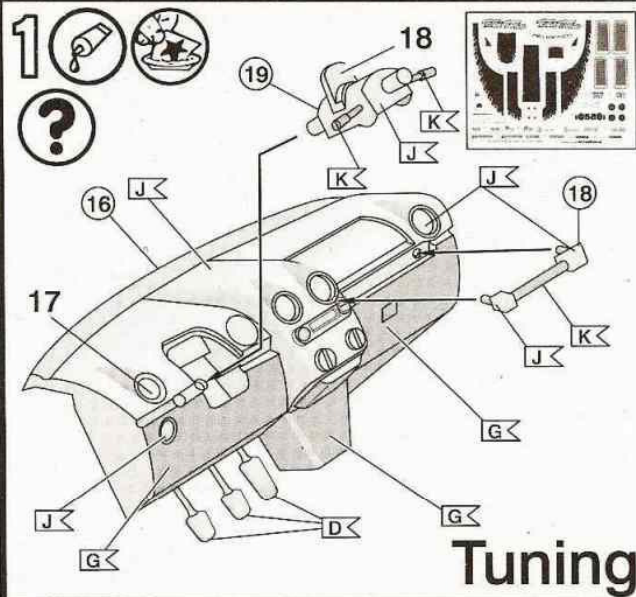

Tuning

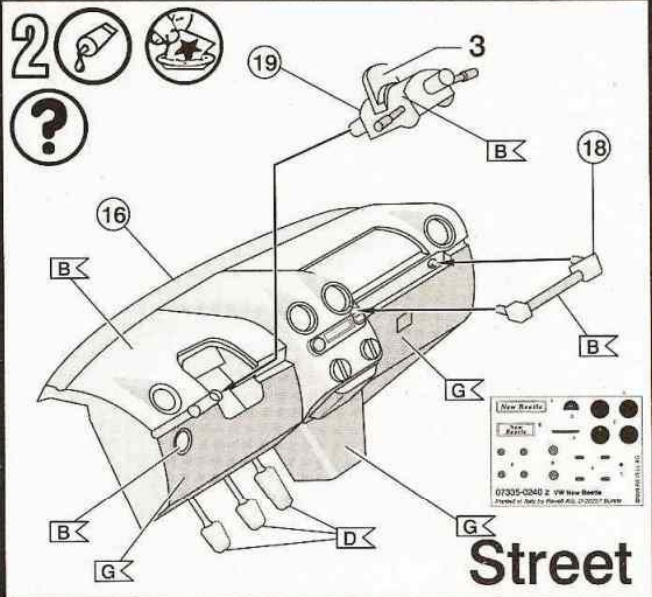

Street

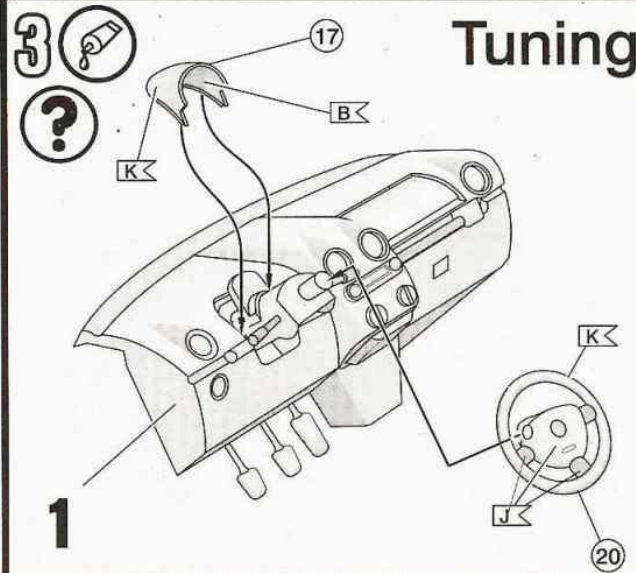

Tuning

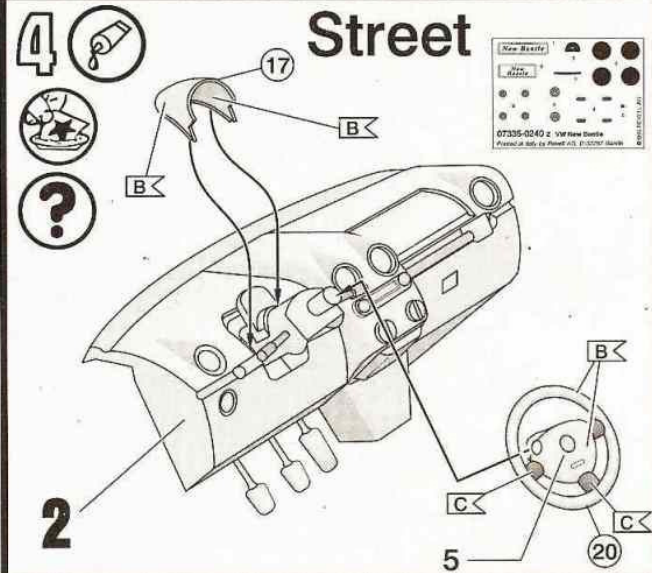

Street

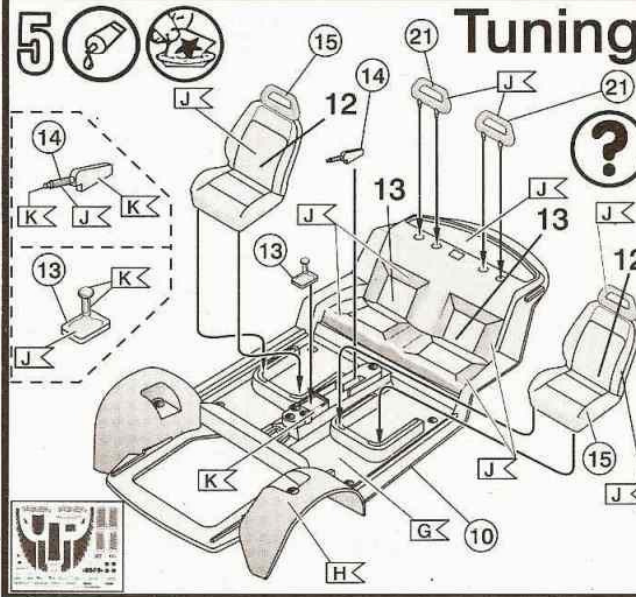

Tuning

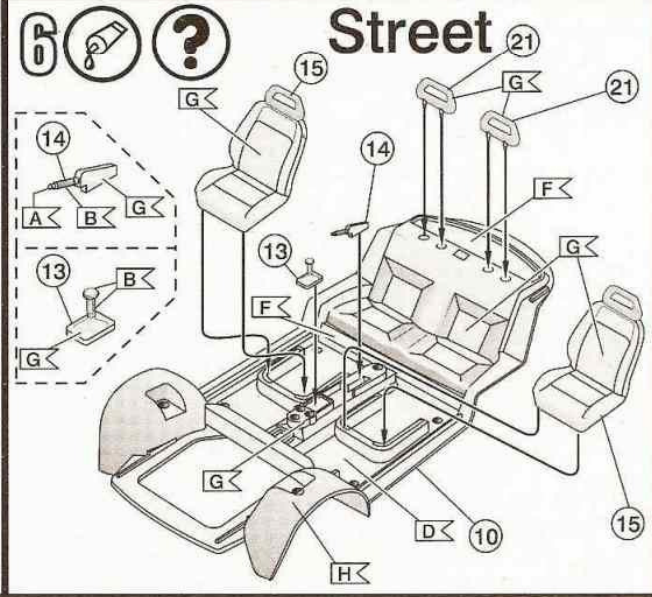

Street

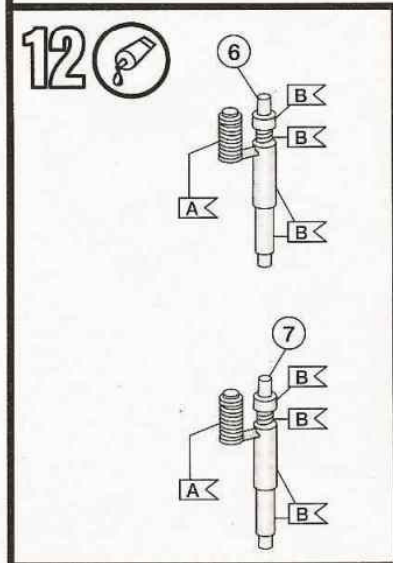
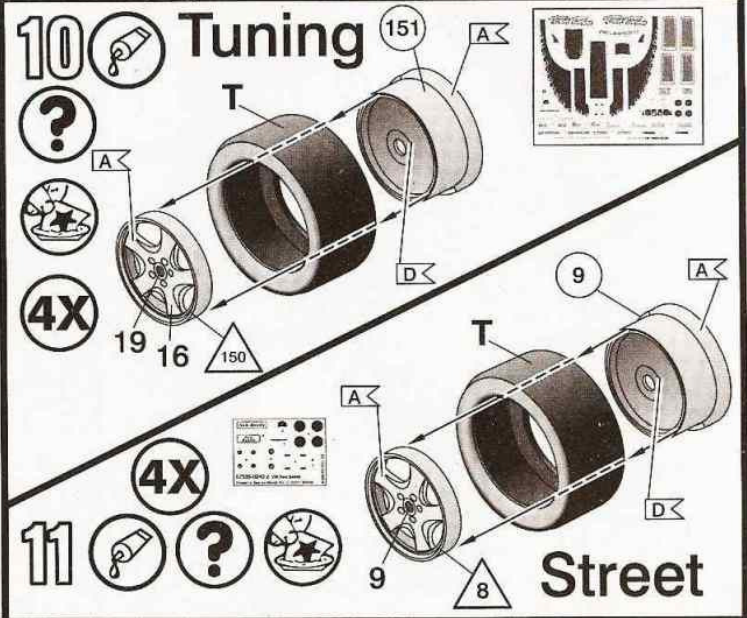
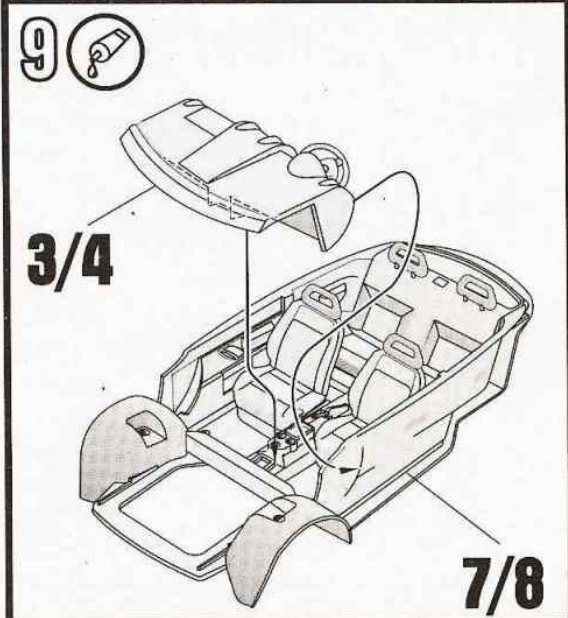
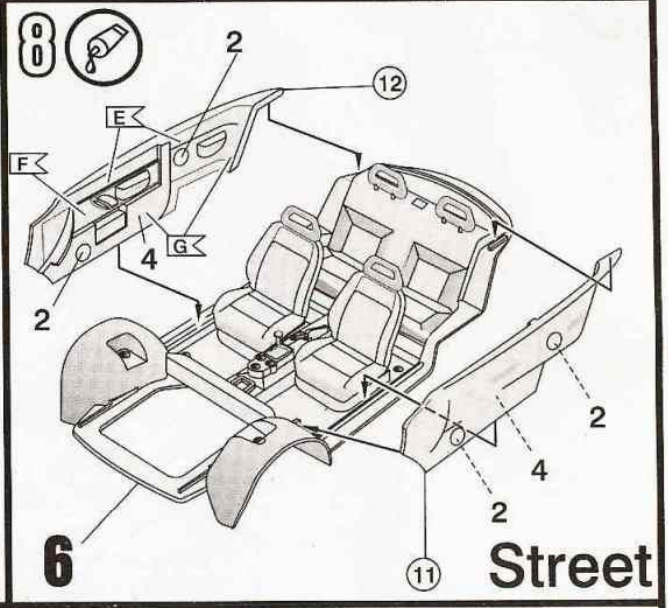
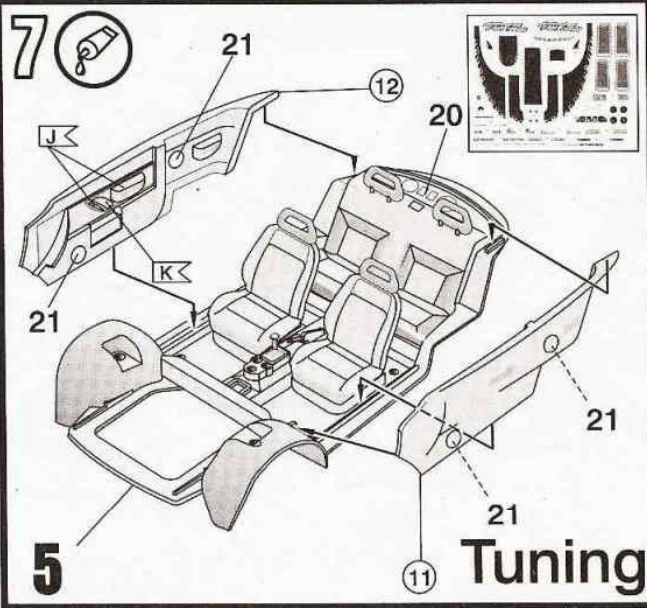

15

Tuning

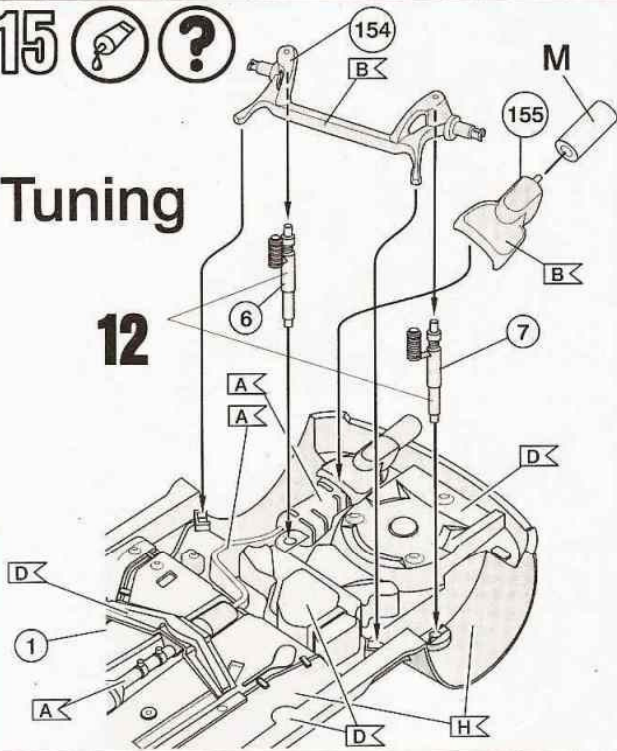

16

12 Street

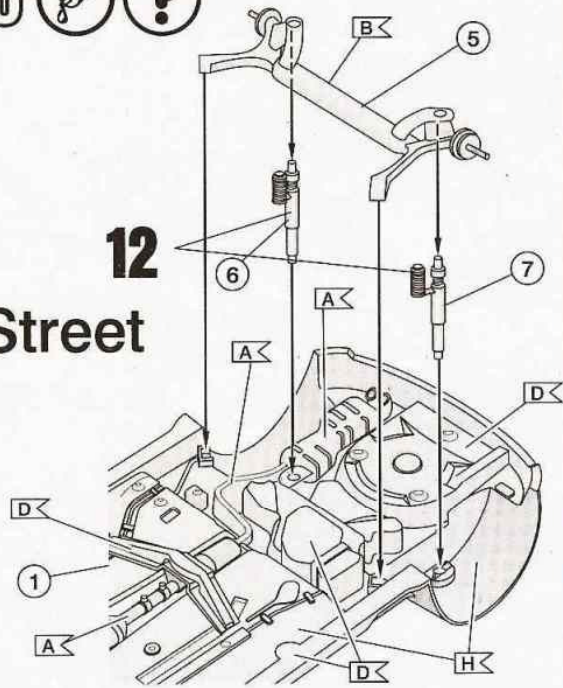

17

15

Tuning

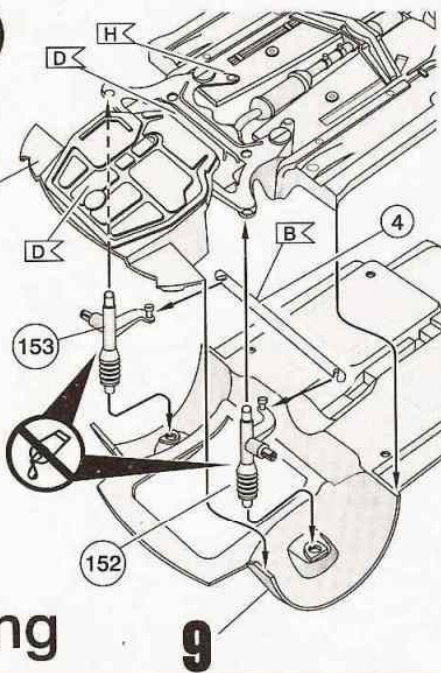

18

16

Street

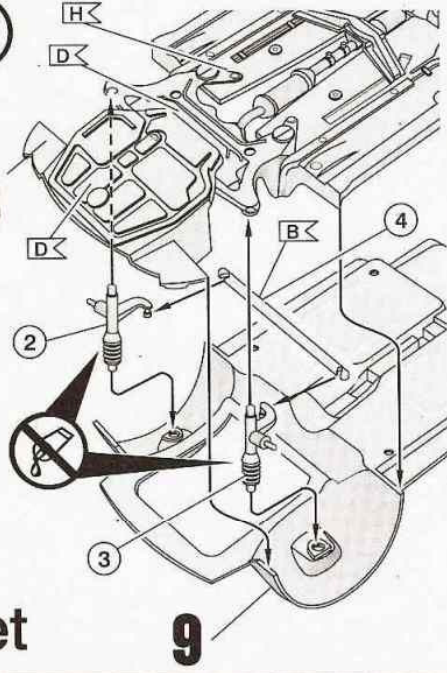

19

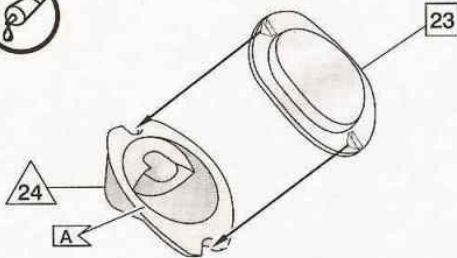

20

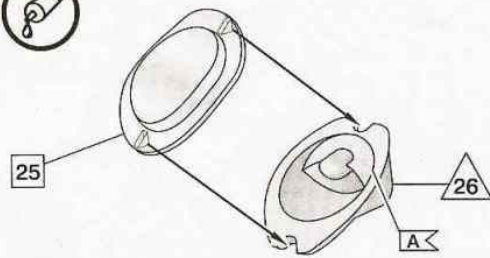

21

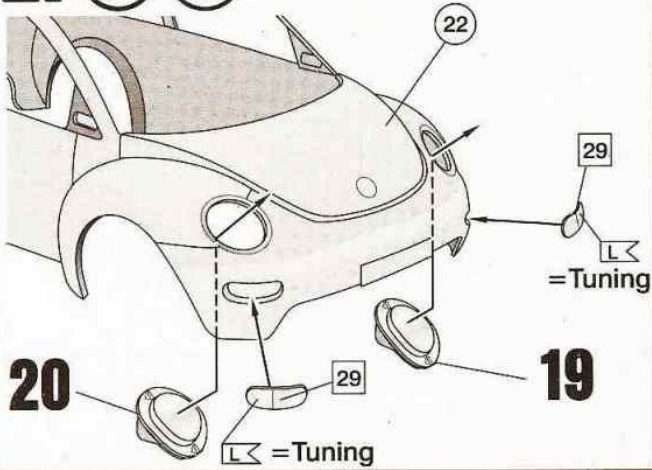

22

Tuning

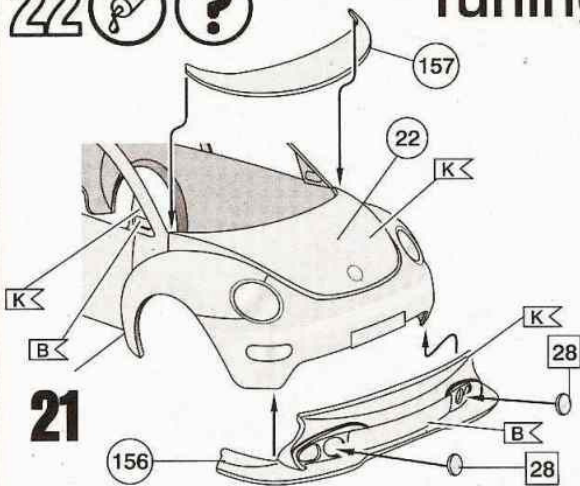

23

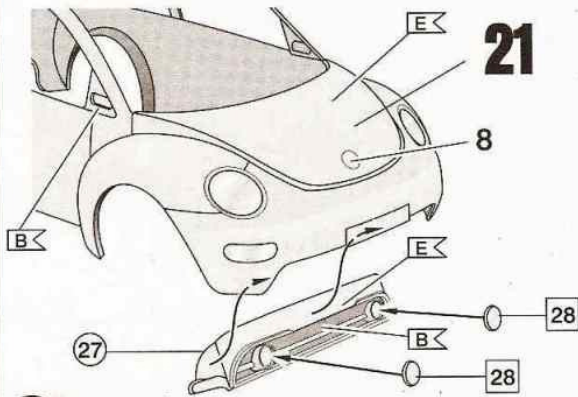

Street

24

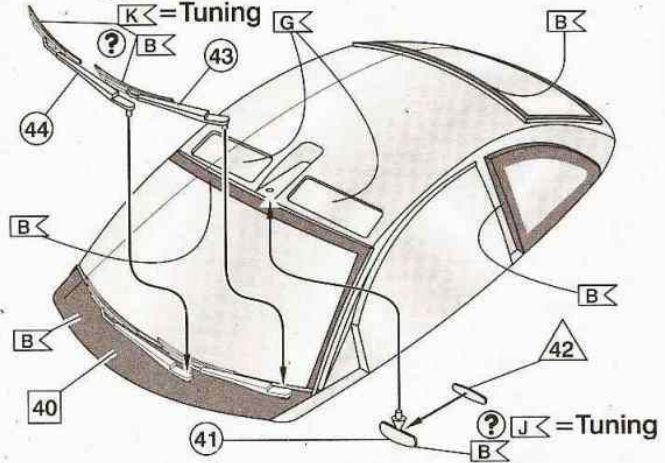

25

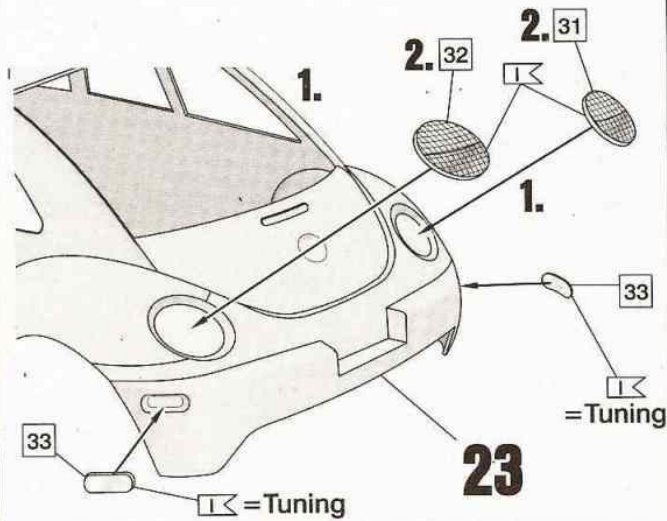

26



Tuning

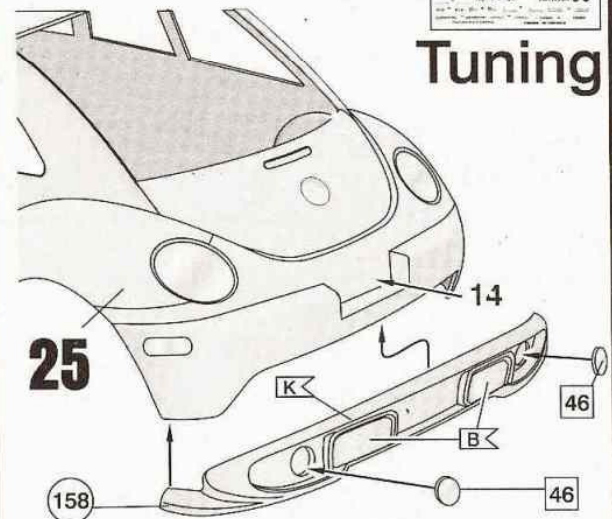

27   

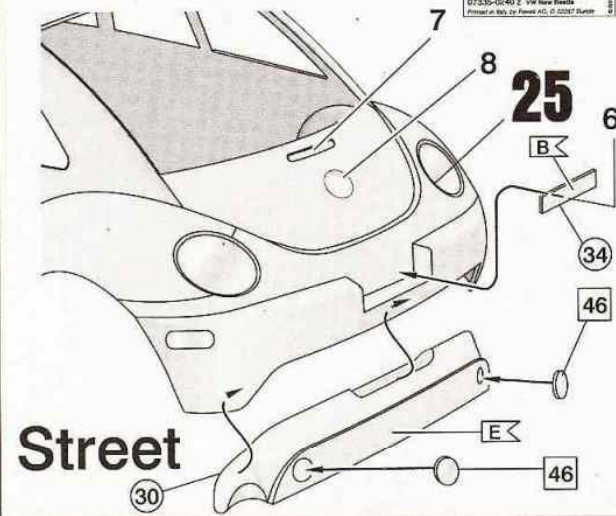
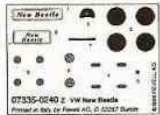

28  

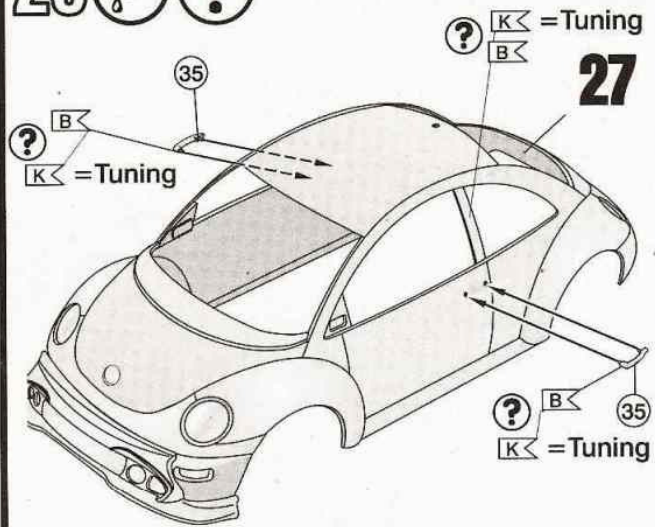

29  

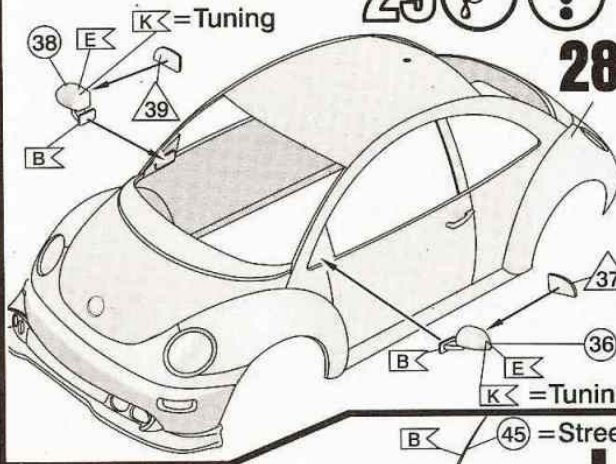

30 

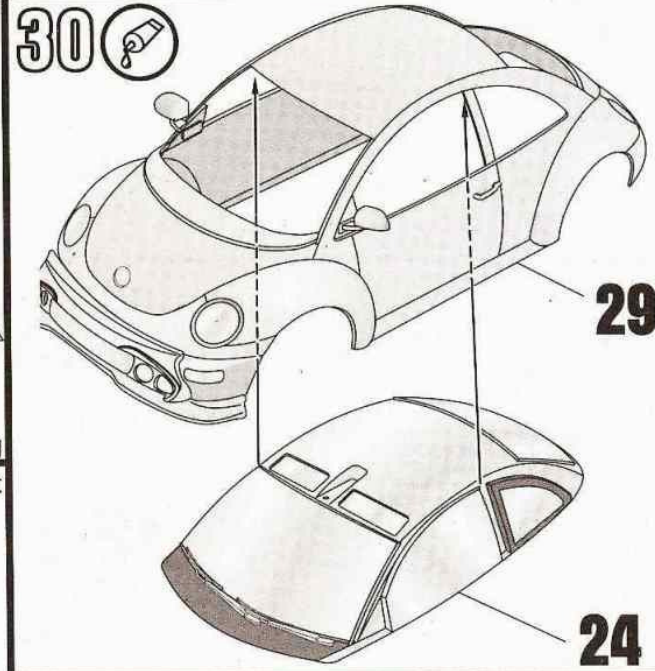

31 



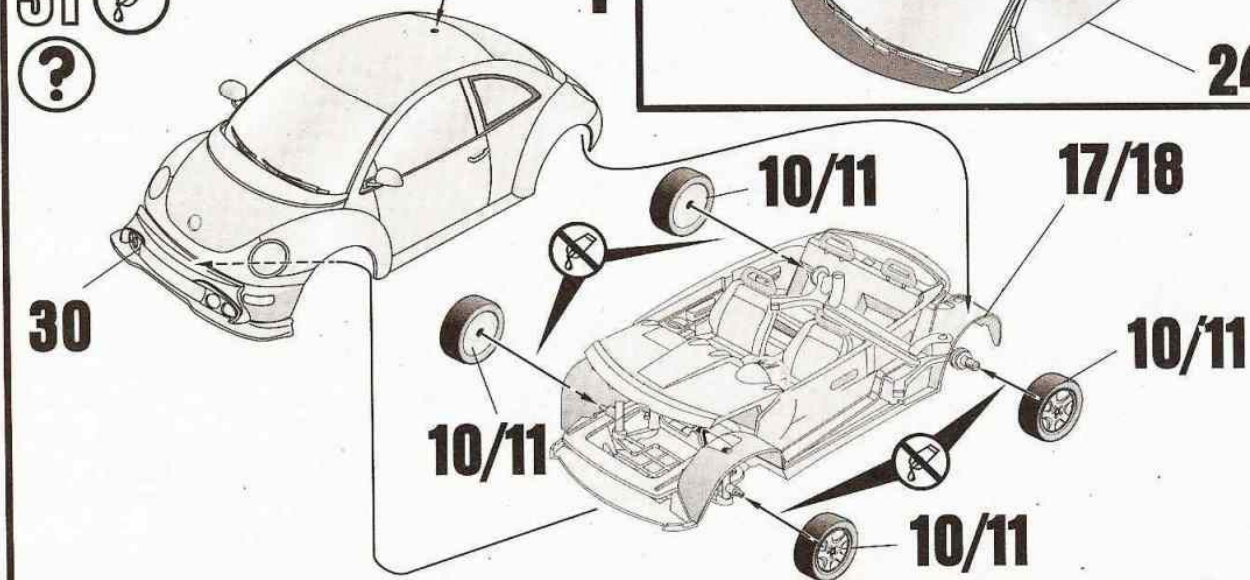

32   

Tuning

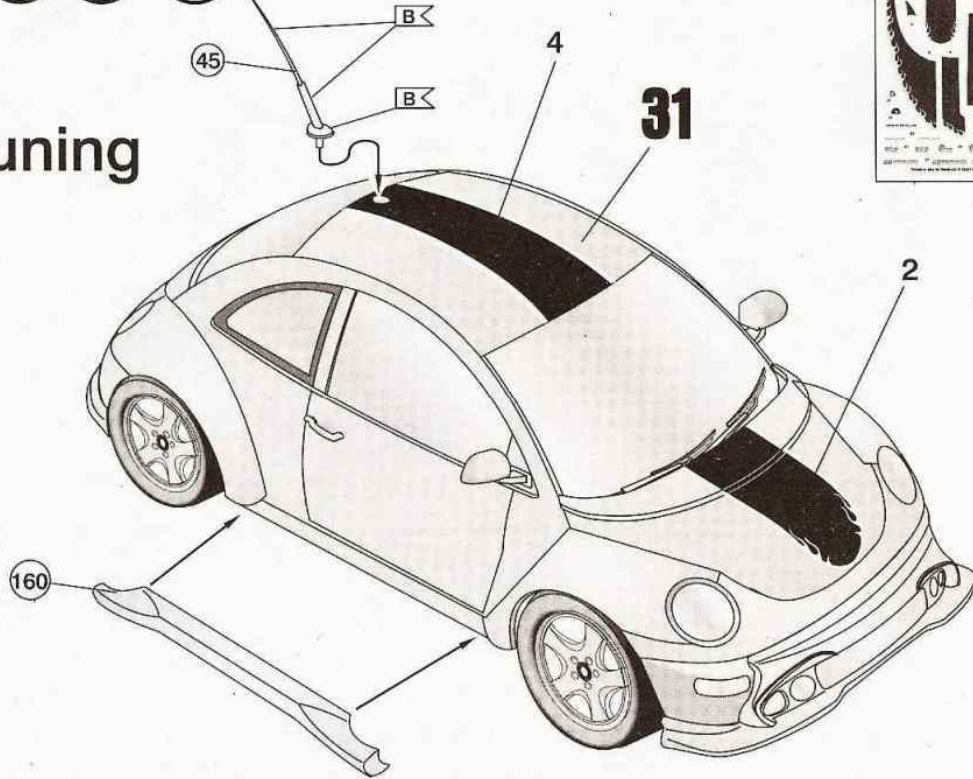

33   

Tuning

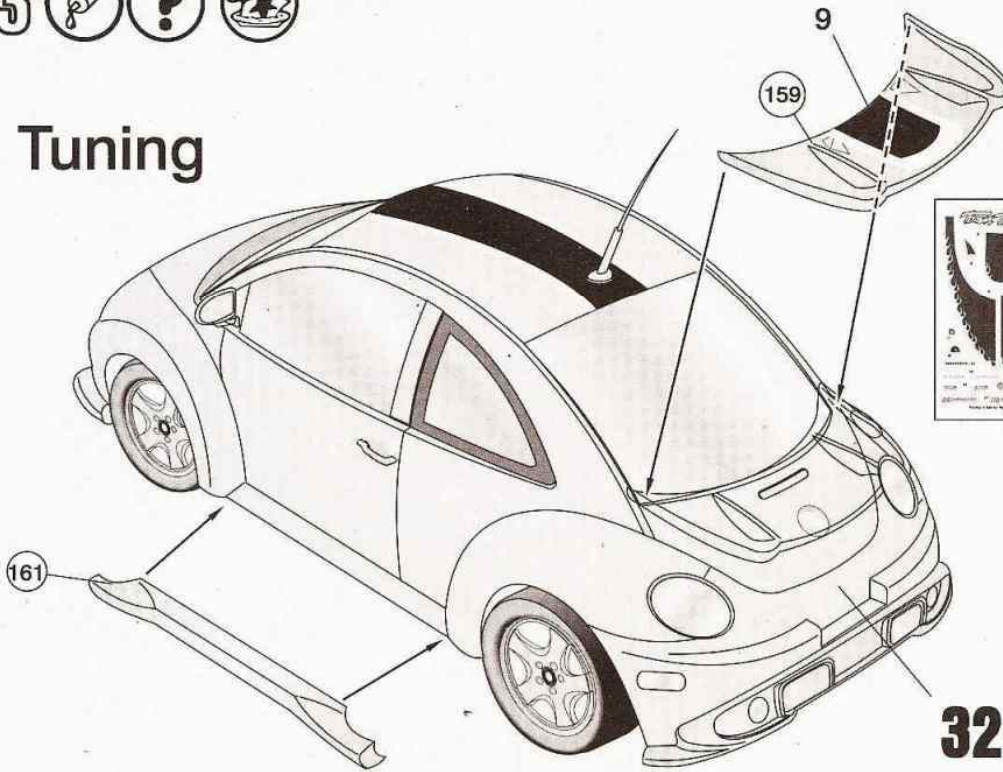

34 

? Tuning

? 5, 6, 7, 8, 10, 11, 22, 25, 28, 27, 24, 23

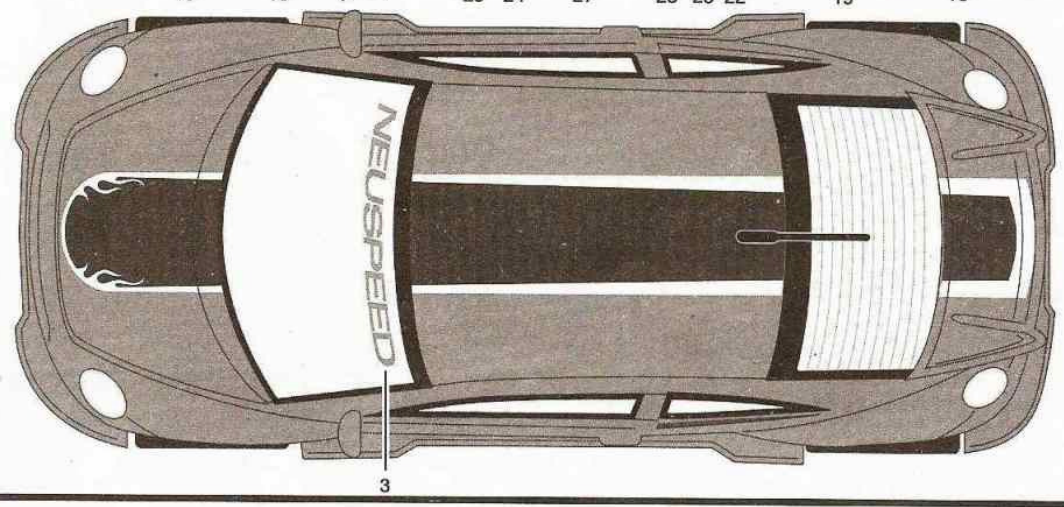
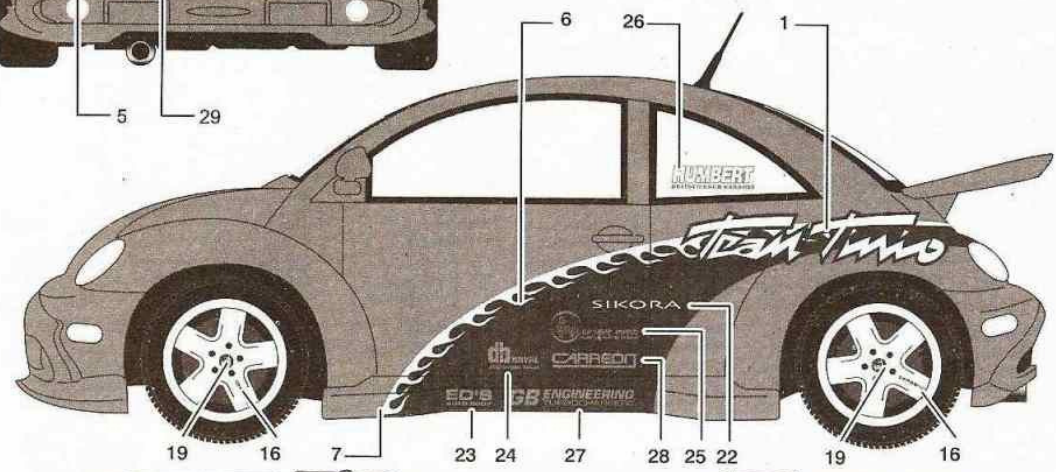
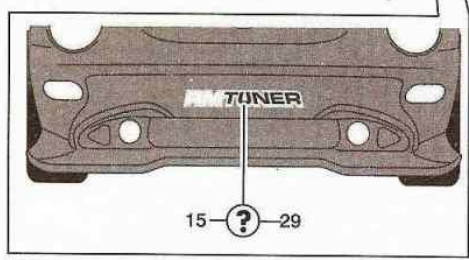
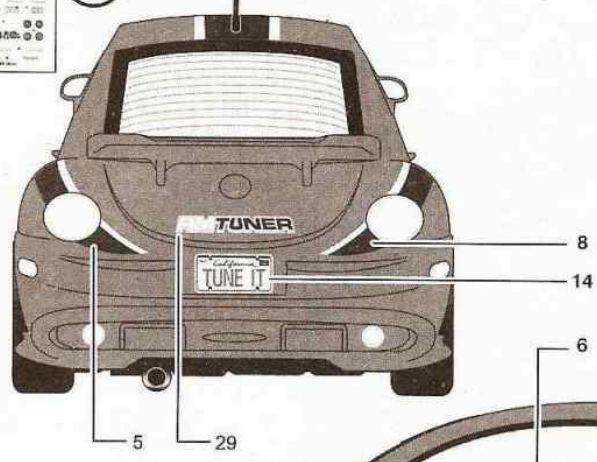
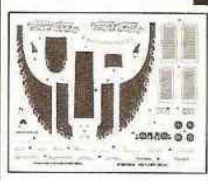
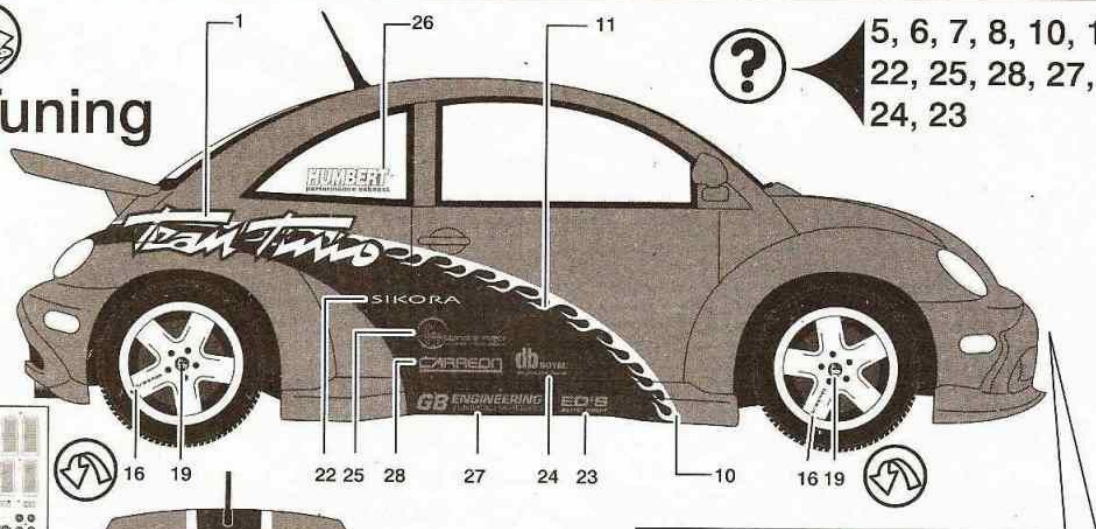

35 

 Street

