



KIT1555

85155500200



'65 Chevy® Impala™ SS™ Convertible

When it came to cars, the big, shiny convertible was every kid's idea of stylish transportation in the 1960's. In the magazine ads, the TV commercials and on the middle of the dealership showroom floor, it was usually a flashy ragtop you first saw. Even though Dad would sometimes wind up with the more useful 4 door sedan or station wagon, the gleam in a youthful eye usually contained a convertible.

For the American motoring public, Chevrolet® was their first choice. The best selling car for many years, the completely new 1965 Impala™ was "longer, lower, wider" just like the advertising copy went. The '65 model had less chrome than had been seen in years

which only accentuated the rounded, fluid lines of the new car. A wide range of powerplants were available from thrifty straight sixes to fire-breathing 409 V8s with 4 speed sticks.

The hottest of the Impala lineup was the SS™. When you checked this box on the order form, you got bucket seats and floor mounted shifter instead of the bench seat and steering column mounted transmission as well as special trim throughout. It's no wonder that all these years later the '65 Chevy convertible has become one of the most popular subjects for the "low 'n slow" crowd of lowrider builders. Some visions of stylish transportation never really change.



*** REPEAT SEVERAL TIMES**
* A REPETER PLUSIEURS FOIS



*** OPTIONAL PARTS**
* PIECES EN OPTION



*** DECAL**
* DECAL COMANIE



*** ALTERNATIVE ASSEMBLY**
* ENSEMBLAGE ALTERNATIVE



*** CEMENT TOGETHER**
* A COLLER



*** REMOVE AND THROW AWAY**
* A RETIRER ET JETER



*** DO NOT CEMENT**
* NE PAS COLLER

WARNING: PLASTIC GLUE COULD CATCH ON FIRE. IT COULD HURT YOU IF IT GETS ON YOUR SKIN OR IN YOUR EYES.

CONTAINS: METHYL ETHYL KETONE.

BE CAREFUL: Do not allow long contact with skin. Wash hands at once after use. Wear thick gloves when in use. Keep away from eyes. Do not smell or eat.

KEEP OUT OF THE REACH OF SMALL CHILDREN.

FIRST AID: If glue gets in your eyes wash with clean water for 5 to 10 minutes. If glue gets on your skin, wash with soap and water for 5 minutes. If you start to feel weak, sick, or your speech becomes slow; go outside then wash hands and remove any clothing with glue on it. If you still do not feel better seek your doctors attention.

For further health questions; contact a poison control center.

AVERTISSEMENT: LA COLLE PLASTIQUE RISQUE DE S'ENFLAMMER ET PEUT ETRE DANGEREUSE SI ELLE TOUCHE LA PEAU OU PENETRE DANS LES YEUX.

COMPOSITION: METHYLETHYLKETONE.

ATTENTION: Empêcher tout contact prolongé avec la peau. Se laver les mains immédiatement après utilisation. Porter des gants épais pendant l'utilisation. Ne pas approcher des yeux. Ne pas sentir ni avaler. Conserver hors de portée des jeunes enfants.

CONSERVER HORS DE PORTÉE DES JEUNES ENFANTS.

PREMIERS SECOURS: Si la colle pénètre dans les yeux, les laver à l'eau propre pendant 5 à 10 minutes. Si la colle adhère à la peau, laver celle-ci à l'eau savonneuse pendant 5 minutes. En cas de faiblesse, de nausées ou de diction pâteuse, sortir dehors, se laver les mains et ôter tout vêtement sur lequel adhère de la colle. Si l'on continue alors à ne pas se sentir bien, consulter un médecin. Pour d'autres questions en matière

READ THIS BEFORE YOU BEGIN

- Study the assembly drawings.
- Each plastic part is identified by a number.
- In the assembly drawings, some parts will be marked by a star (*) to indicate chrome plated plastic.
- For better paint and decal adhesion, wash the plastic parts in a mild detergent solution. Rinse and let air dry.
- Check the fit of each piece before cementing in place.
- Use only cement for polystyrene plastic.
- Scrape plating and paint from areas to be cemented.
- Allow paint to dry thoroughly before handling parts.
- Any unused parts may be discarded.

LIRE CE QUI SUIT AVANT DE COMMENCER

- Etudier les schémas de montage.
- Chaque pièce en plastique est identifiée par un numéro.
- Sur les schémas de montage, certaines pièces sont marquées d'une étoile (*) pour indiquer qu'elles sont en plastique chromé.
- Pour une meilleure prise de la peinture et des autocollants, laver les pièces en plastique avec une solution détergente peu concentrée. Les rincer et les laisser sécher à l'air.
- Vérifier que chaque pièce s'ajuste bien avant de la coller en place.
- N'utiliser que de la colle pour polystyrène.
- Gratter les parties à coller pour enlever le chrome et la peinture.
- Laisser la peinture bien sécher avant de manipuler les pièces.
- Toute pièce inutilisée peut être jetée.

This optional paint guide is provided to detail this kit. Ce guide facultatif de peinture est fourni pour détailler cette trousse.

Chevy Engine Orange	<i>Orange moteur Chevrolet</i>
Flat Black	<i>Noir mat</i>
Silver	<i>Argent</i>

If you have any questions or comments, call our hotline at: **(800) 833-3570** or, please write to:

Revell-Monogram Consumer Service Department, 725 Landwehr, Northbrook, Illinois 60062

Be sure to include the plan number (85155500200), part number, description, your return address and phone number.

Visit our website: www.revell-monogram.com

1

ENGINE ASSEMBLY

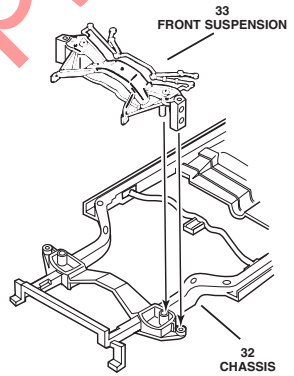
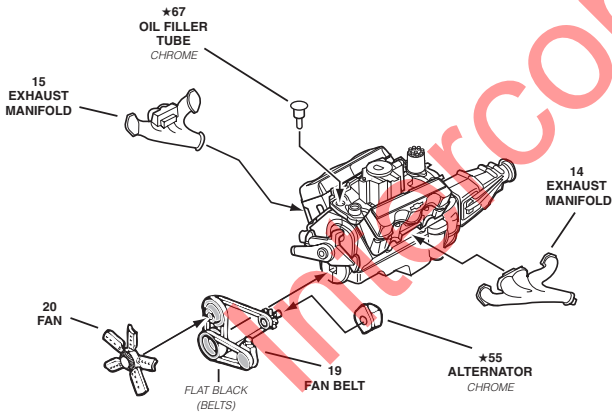
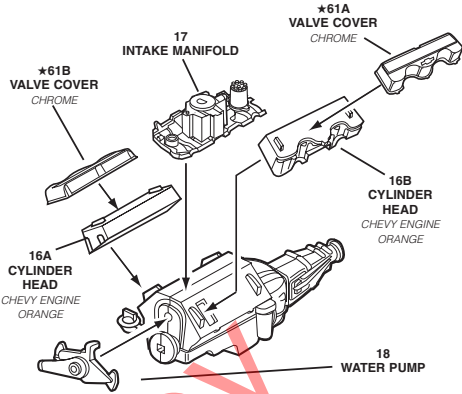
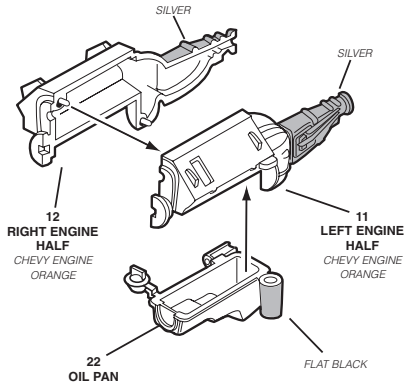

COMPLETED
ENGINE
ASSEMBLY

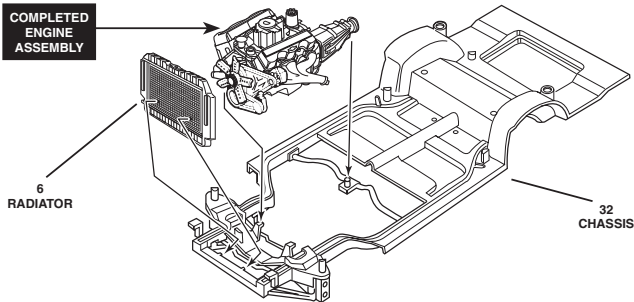

2

EXHAUST AND SUSPENSION ASSEMBLY

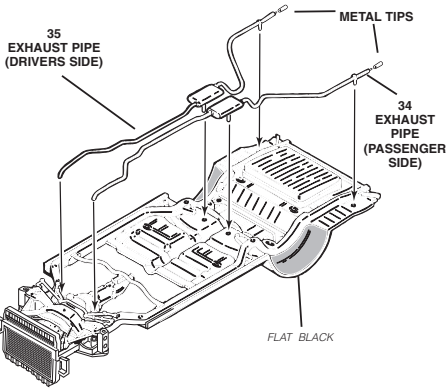

USE FOR RAISED VERSION

37C&D
RAISED REAR
SPRINGS



36
REAR AXLE

36B
DRIVESHAFT

37A
LOWERED LEFT
REAR SPRING

38B
LOWERED RIGHT
REAR SPRING

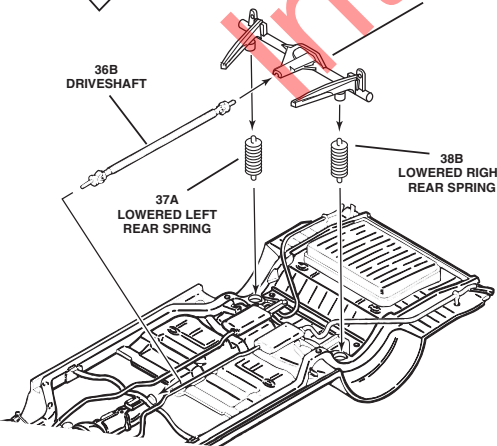

NOTE: PICK A RIDE HEIGHT FOR THE SHOCKS AND SPRINGS. ONCE THE RIDE HEIGHT IS PLACED YOU CANNOT BUILD THE OTHER VERSION

LOWERED

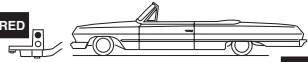

LOWERED

RAISED

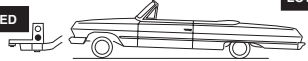

LOWERED



RAISED

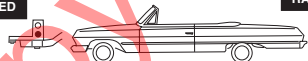

RAISED

USE FOR RAISED VERSION

41A&B
RAISED REAR
SHOCKS



41D
LOWERED LEFT
REAR SHOCK

41C
LOWERED LEFT
REAR SHOCK

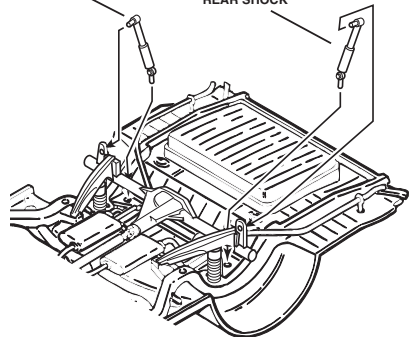

3

INTERIOR ASSEMBLY

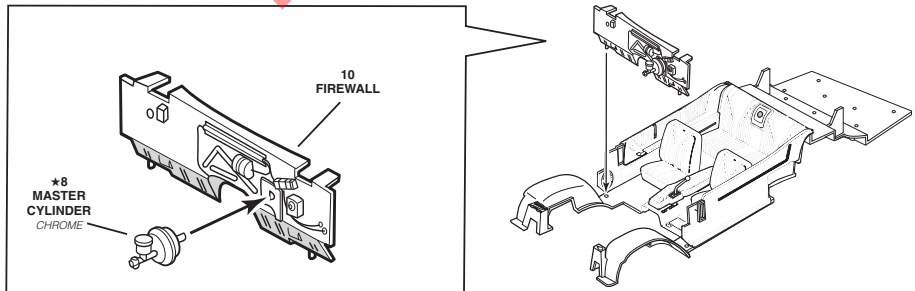
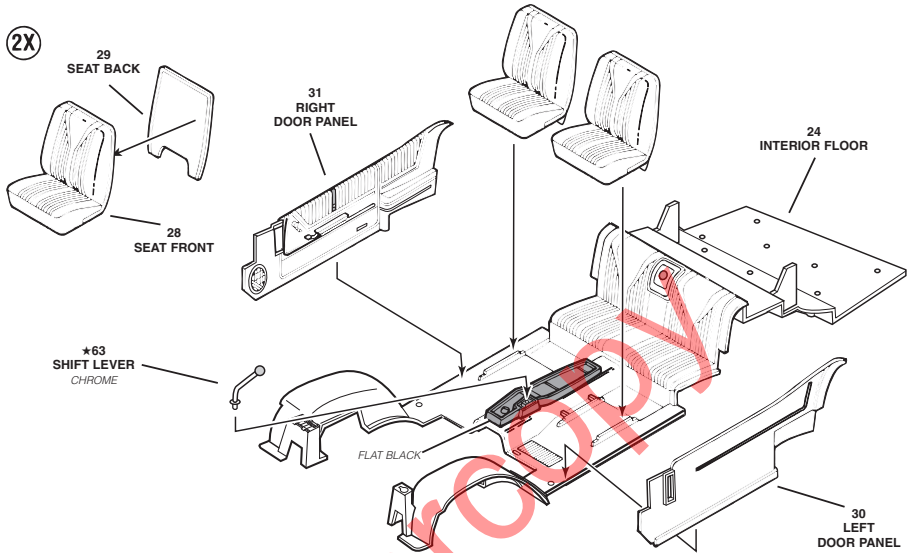

3

INTERIOR ASSEMBLY CONTINUED

25
DASHBOARD
PAIN'T TRIM SILVER

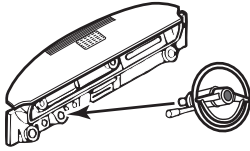

26
STEERING COLUMN

SILVER STALK

27
STEERING WHEEL
PAIN'T HORN RING SILVER

COMPLETED
DASHBOARD
ASSEMBLY

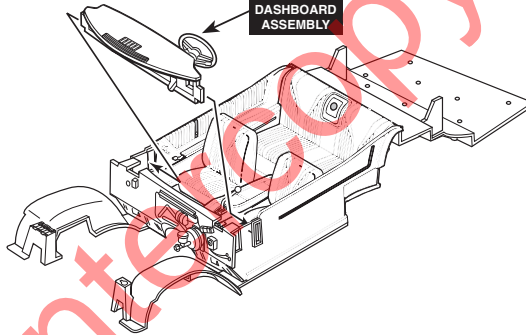

*69
PRE AMP
CHROME

40
BATTERY PACK
FLAT BLACK WITH SILVER CONTACTS

**60
HYDRAULIC
PUMPS
GOLD PLATED

40
BATTERY PACK
FLAT BLACK WITH SILVER CONTACTS

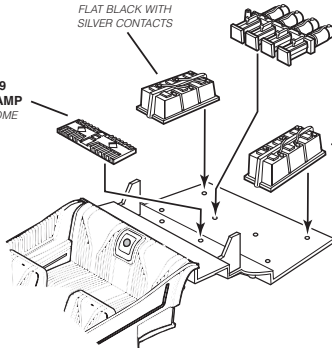

4

BODY AND CHASSIS ASSEMBLY

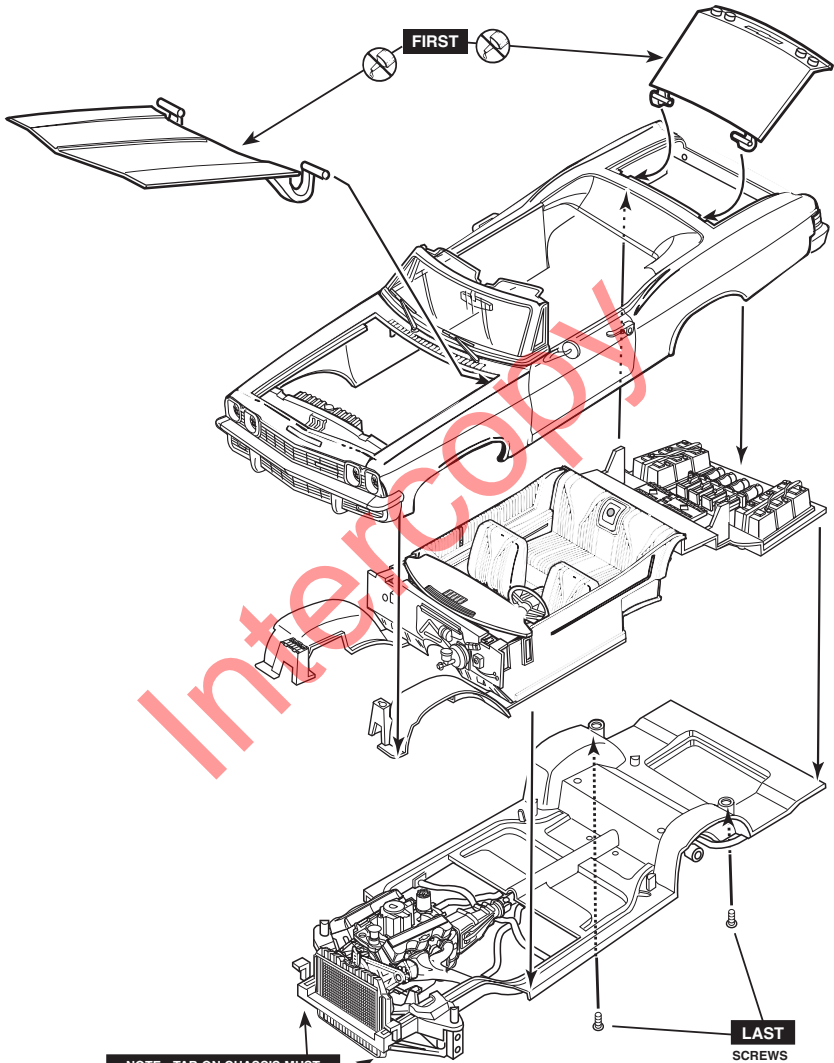

5

WHEEL ASSEMBLY

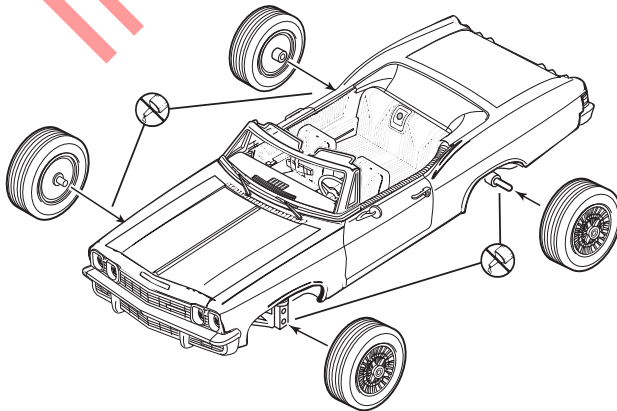
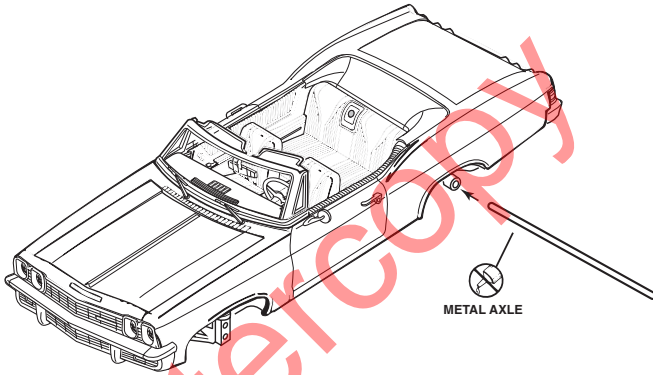
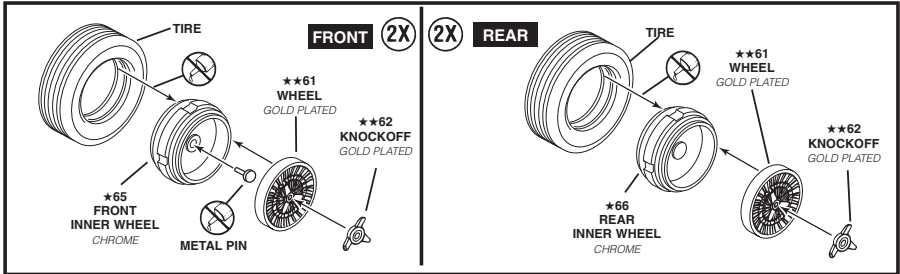

HOOD OMITTED FOR CLARITY

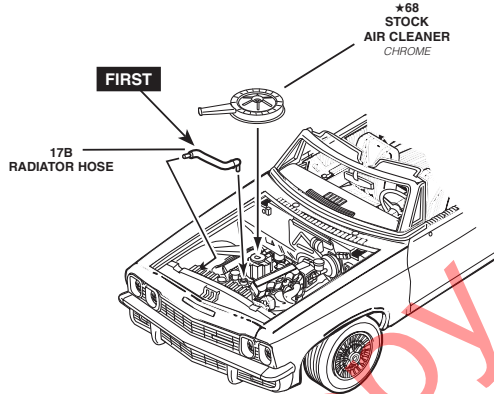

NOTE: THE CONTROL LEVER MAY BE GLUED TO A SEAT OR THE CONSOLE IN THE INTERIOR, OR A PIECE OF THREAD (NOT INCLUDED) MAY BE GLUED TO THE CONTROL LEVER AND UNDERNEATH THE DASH SO THE CONTROL LEVER CAN BE DISPLAYED OUTSIDE THE CAR.

