



KIT2187

85218700200

Ford Focus SVT Tuner Series 2'n 1

Truly a world car for the masses, the Ford Focus is produced in many different versions in many different countries. Here in the USA, with the top selling American vehicles list in the last few years dominated by trucks and sport utility vehicles, the Focus is a runaway sales success. Its combination of good fuel mileage and sizable cargo space makes it a very practical car. Practical cars, however, aren't always the most fun type of car to drive

if you tend to lean that way. That's where Ford engineers went to work and built in tight, neutral handling characteristics. The higher performing 170 horsepower version of the Focus four cylinder engine found in the SVT model transforms this practical car into a serious pocket rocket. It's no wonder that so many into the tuner car scene have picked up on the Focus SVT.



* REPEAT SEVERAL TIMES
* A REPETER PLUSIEURS FOIS



* OPTIONAL PARTS
* PIECES EN OPTION



* DECAL
* DECAL COMANIE



* ALTERNATIVE ASSEMBLY
* ENSEMBLAGE ALTERNATIVE



* CEMENT TOGETHER
* A COLLER



* REMOVE AND THROW AWAY
* A RETIRER ET JETER



* DO NOT CEMENT
* NE PAS COLLER

READ THIS BEFORE YOU BEGIN

- * Study the assembly drawings.
- * Each plastic part is identified by a number.
- * In the assembly drawings, some parts will be marked by a star (★) to indicate chrome plated plastic.
- * For better paint and decal adhesion, wash the plastic parts in a mild detergent solution. Rinse and let air dry.
- * Check the fit of each piece before cementing in place.
- * Use only cement for polystyrene plastic.
- * Scrape plating and paint from areas to be cemented.
- * Allow paint to dry thoroughly before handling parts.
- * Any unused parts may be discarded.

DECAL APPLICATION INSTRUCTIONS

1. Cut desired decal from sheet.
2. Dip decal in water for a few seconds.
3. Place wet decal on paper towel.
4. Wait until decal is movable on paper backing.
5. Place decal in position on model, face up and slide backing away.
6. Press out air bubbles with a soft damp cloth.
7. Milkyness that may appear is for better decal adhesion and will dry clear. Wipe away any excess adhesive.
8. Do not touch decal until fully dry.
9. Allow the decals 48 hours to dry before applying clear coat.

NOTE: Decals are compatible with setting solutions or solvents.

LIRE CE QUI SUIT AVANT DE COMMENCER

- * Etudier les schémas de montage.
- * Chaque pièce en plastique est identifiée par un numéro.
- * Sur les schémas de montage, certaines pièces sont marquées d'une étoile (★) pour indiquer qu'elles sont en plastique chromé.
- * Pour une meilleure prise de la peinture et des autocollants, laver les pièces en plastique avec une solution détergente peu concentrée. Les rincer et les laisser sécher à l'air.
- * Vérifier que chaque pièce s'ajuste bien avant de la coller en place.
- * N'utiliser que de la colle pour polystyrène.
- * Gratter les parties à coller pour enlever le chrome et la peinture.
- * Laisser la peinture bien sécher avant de manipuler les pièces.
- * Toute pièce inutilisée peut être jetée.

DIRECTIVES D'APPLICATION DES AUTOCOLLANTS

1. Découper l'autocollant désiré de la feuille.
2. Tremper l'autocollant dans de l'eau pendant quelques secondes.
3. Placer l'autocollant mouillé sur une serviette en papier.
4. Attendez que l'autocollant puisse être déplacé sur son support en papier.
5. Mettre l'autocollant en position sur le modèle face sur le dessus et faire glisser le support pour l'enlever.
6. Appuyer avec un chiffon doux humide pour éliminer les bulles d'air.
7. La substance laiteuse qui peut apparaître est destinée à améliorer l'adhésion de l'autocollant et devient incolore au séchage. Essuyer pour enlever tout excédent d'adhésif.
8. Ne pas toucher l'autocollant tant qu'il n'est pas bien sec.
9. Laisser l'autocollant sécher pendant 48 heures avant d'appliquer une couche transparente.

REMARQUE: Les autocollants sont compatibles avec les solutions de fixation ou les solvants.

This optional paint guide is provided if you choose to detail paint your model.

Ce guide de peinture vous sera fourni si vous choisissez de peindre votre modèle en détail.

Aluminium	Aluminium
Flat Black	Noir mat
Flat Dark Gray	Gris foncé mat
Flat Intermediate Blue	Bleu intermédiaire mat
Flat Yellow	Jaune mat
Gloss Black	Noir brillant
Gloss Dark Blue	Bleu foncé brillant
Gloss Yellow	Jaune brillant
Semigloss Black	Noir satiné
Satin White	Blanc satiné
Silver	Argent
Steel	Acier
Turn Signal Amber	Feu clignotant de direction ambre

If you have any questions or comments, call our hotline at: **(800) 833-3570**
or, please write to:

Revell-Monogram Consumer Service Department, 725 Landwehr Road, Northbrook, Illinois 60062

Be sure to include the plan number (85218700200), part number, description, your return address and phone number.

Visit our website: www.revell-monogram.com

1

ENGINE ASSEMBLY

NOTE: ITALICIZED COLOR CALLOUTS ARE FOR THE STOCK VERSION AND THE BOLD ITALICIZED CALLOUTS ARE FOR THE CUSTOM VERSION

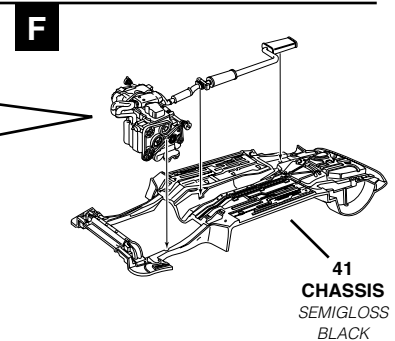
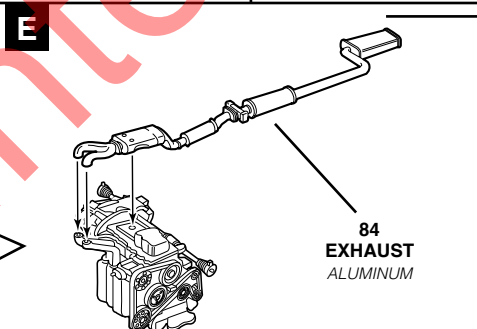
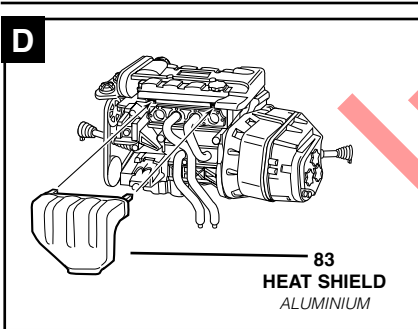
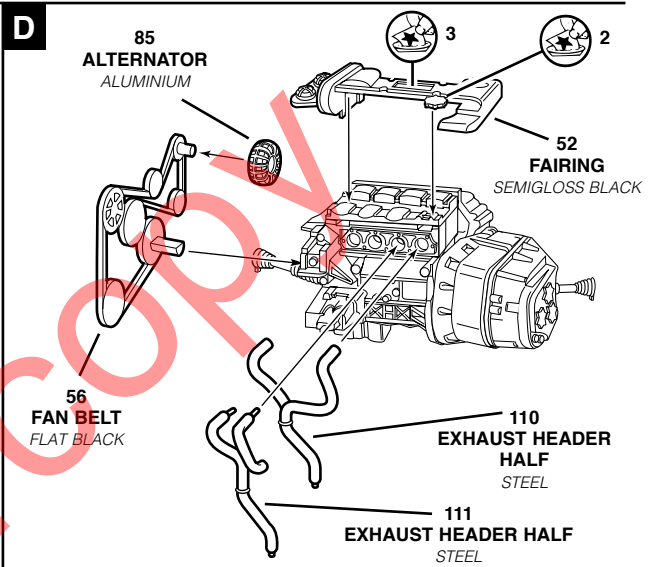
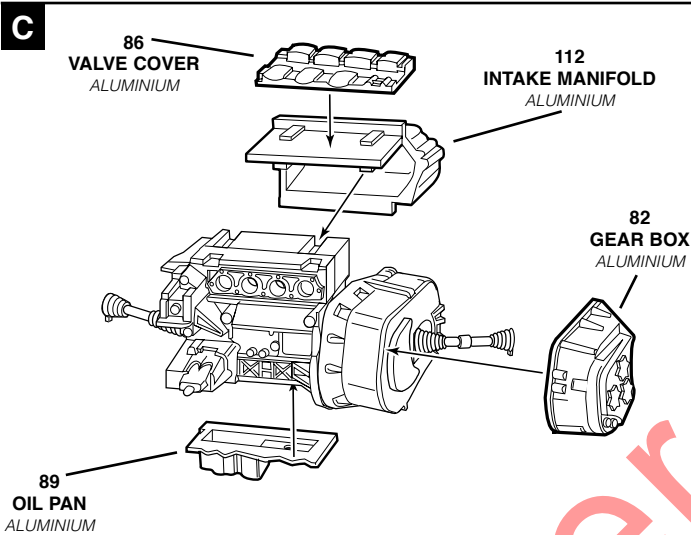
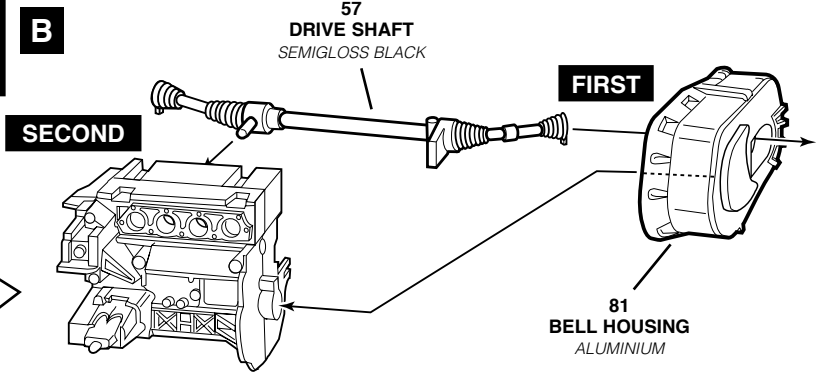
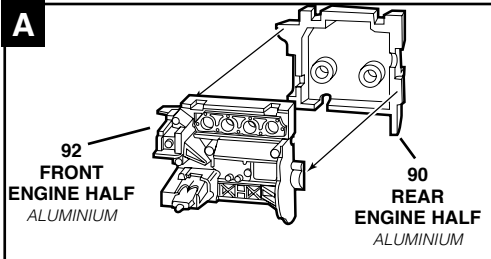

2

SUSPENSION ASSEMBLY

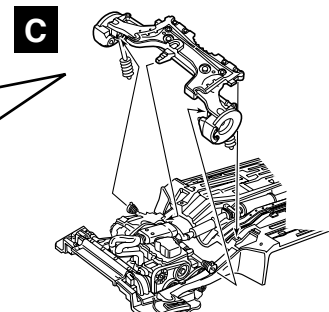
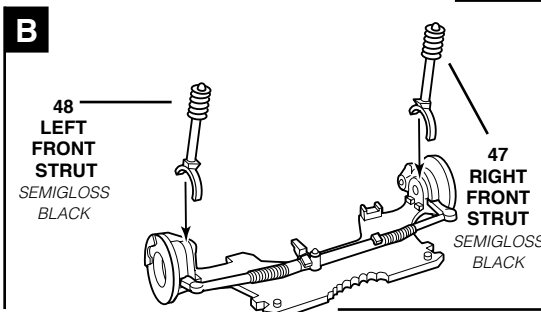
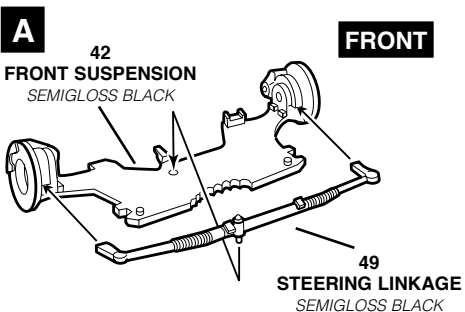

2

SUSPENSION ASSEMBLY CONTINUED

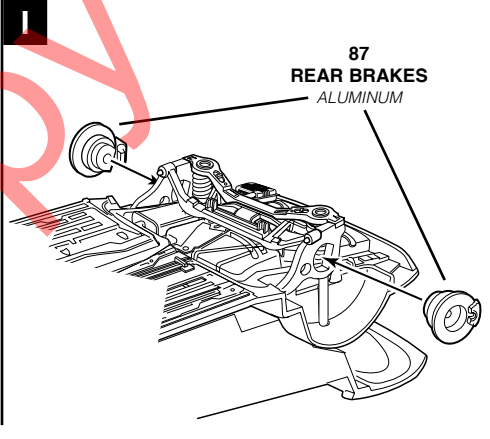
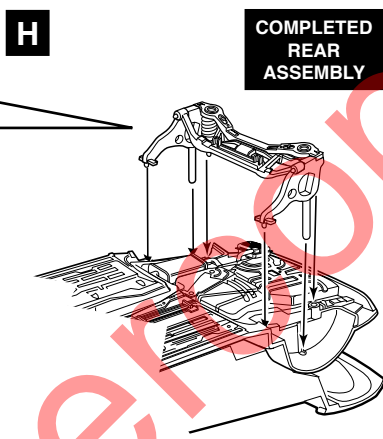
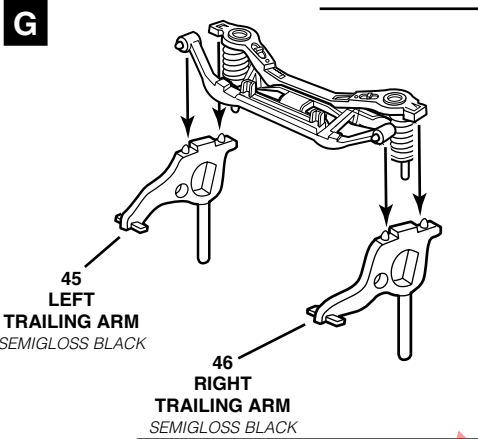
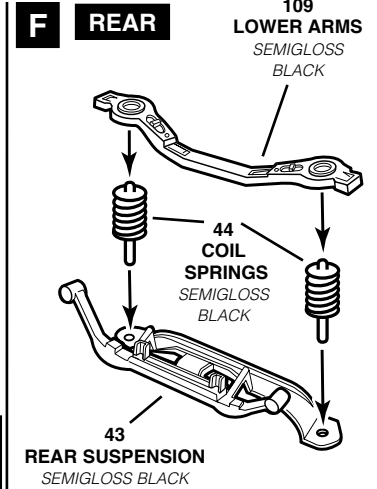
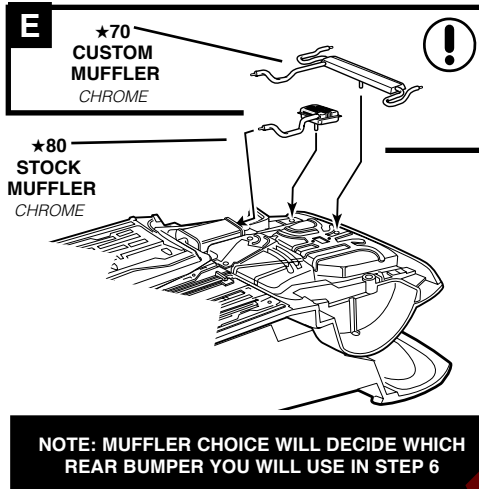
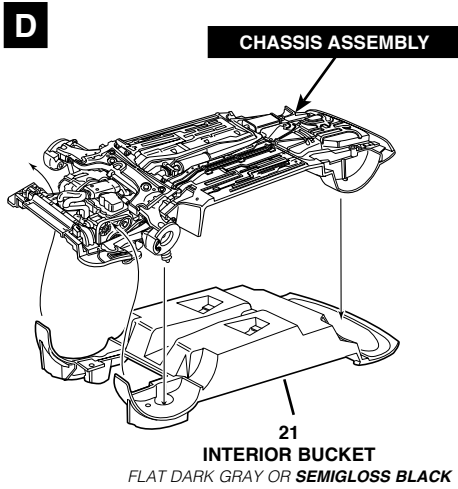

3

ENGINE COMPARTMENT ASSEMBLY

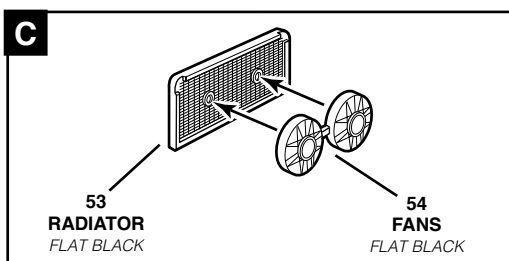
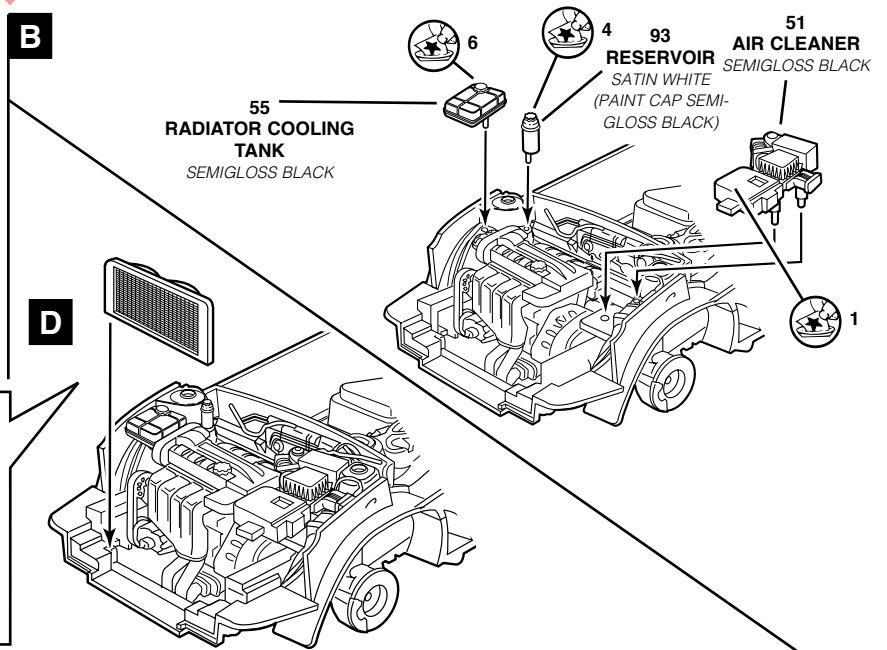
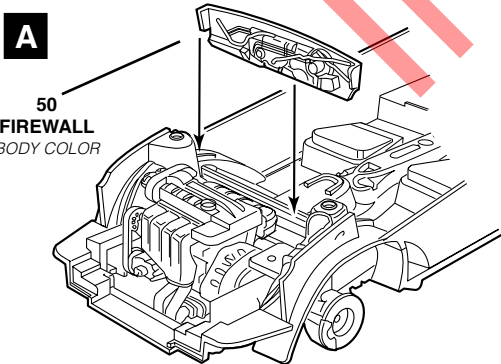

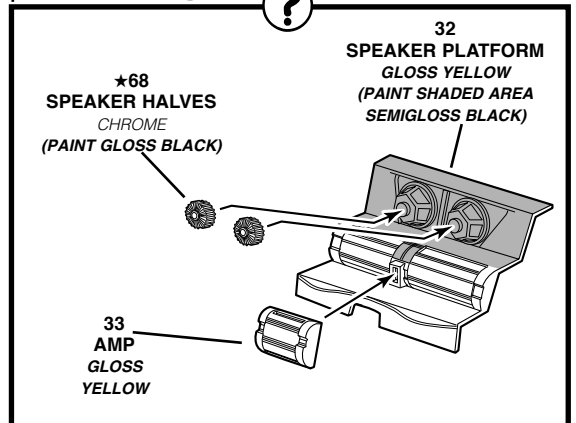
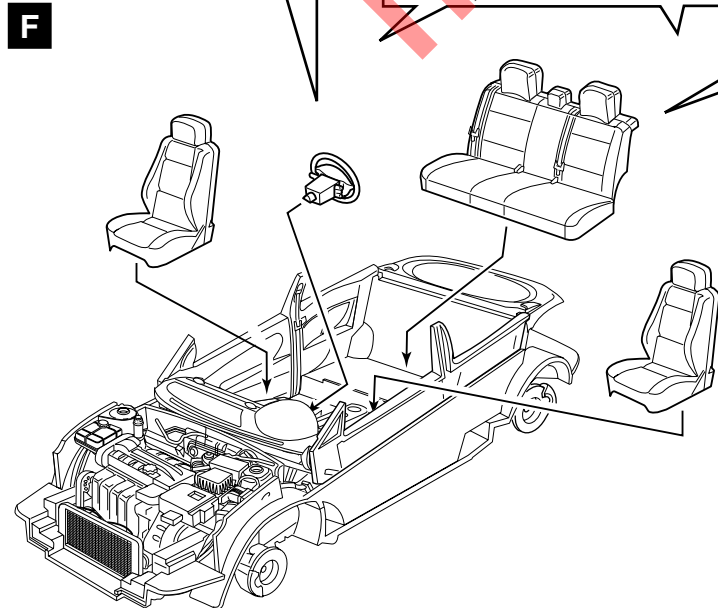
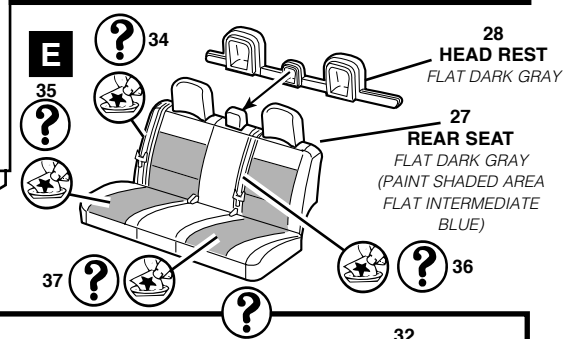
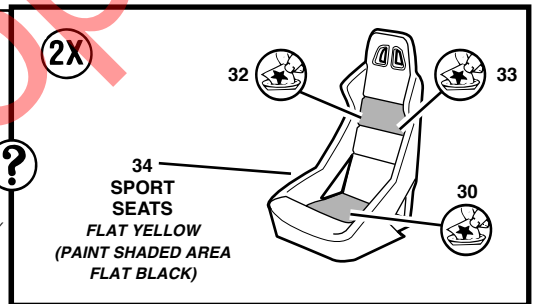
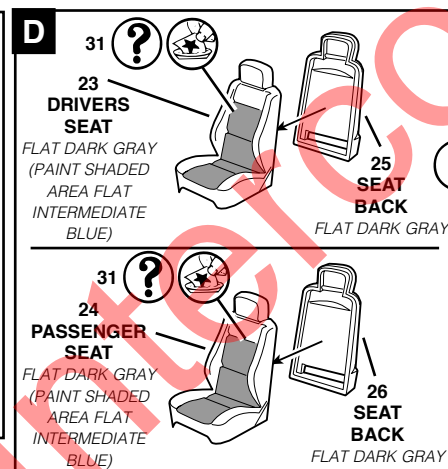
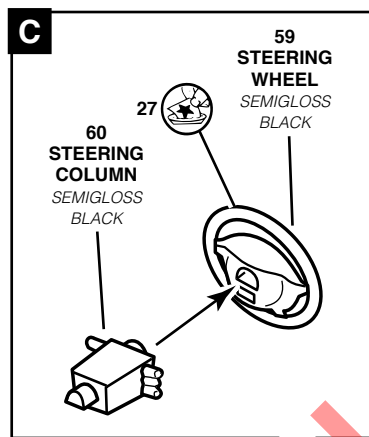
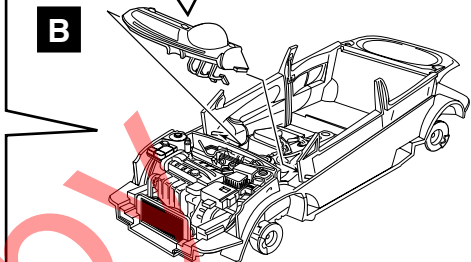
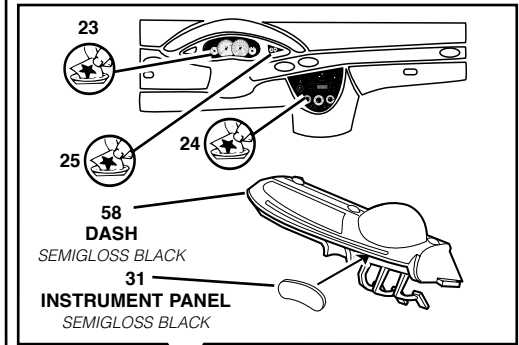
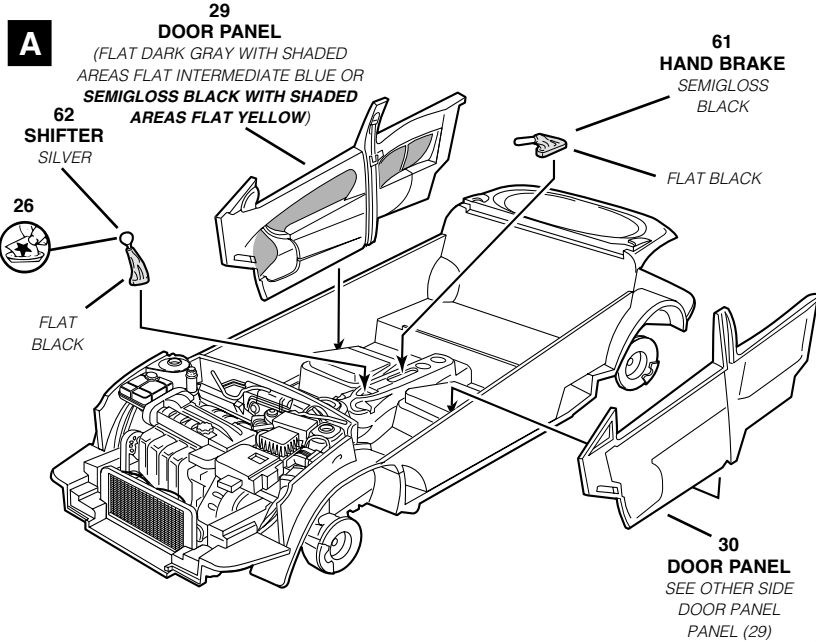

5

VISOR AND SIDE SILLS ASSEMBLY

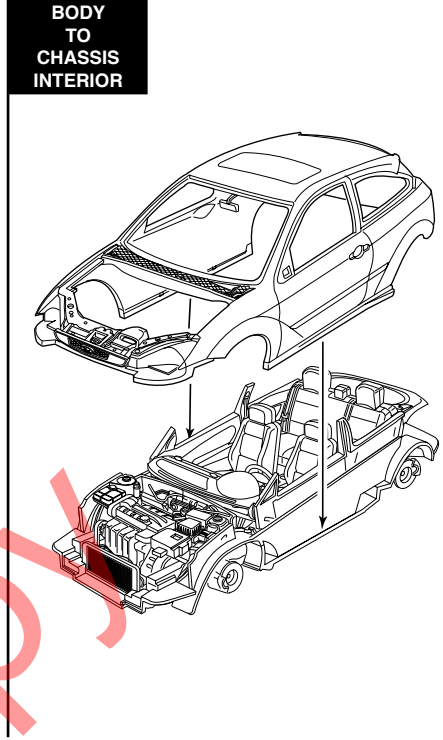
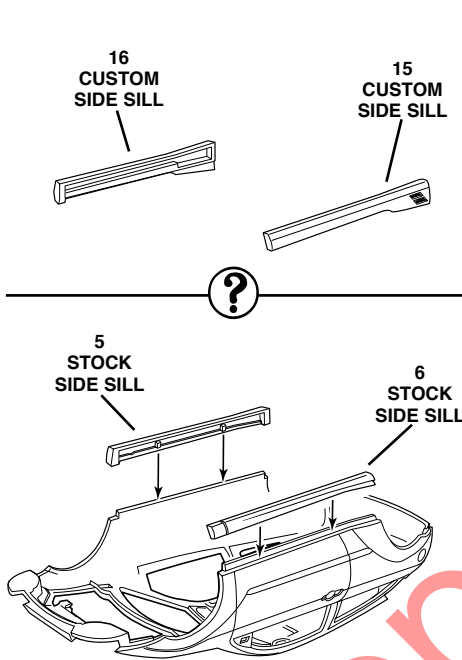
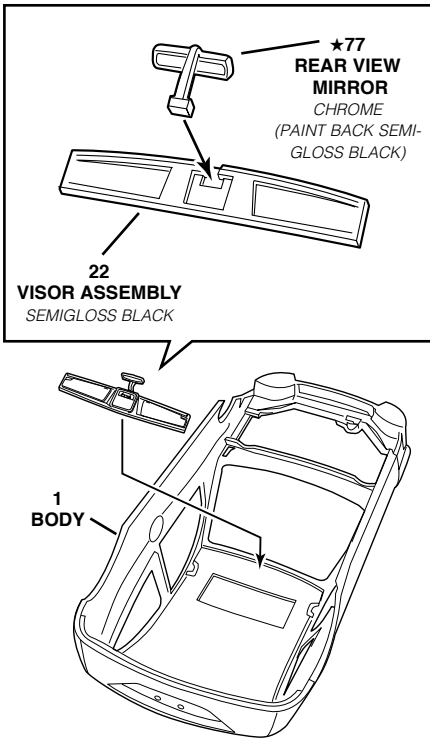

6

BODY ASSEMBLY

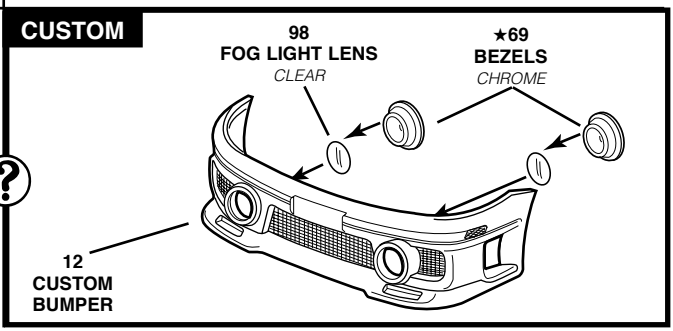
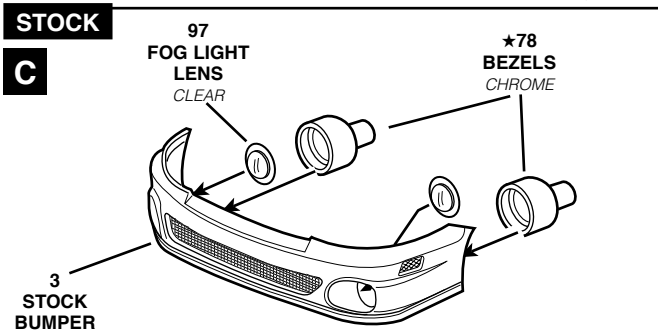
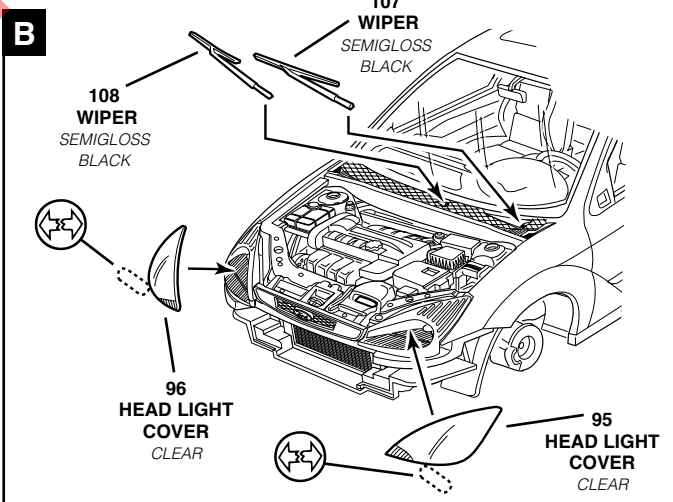
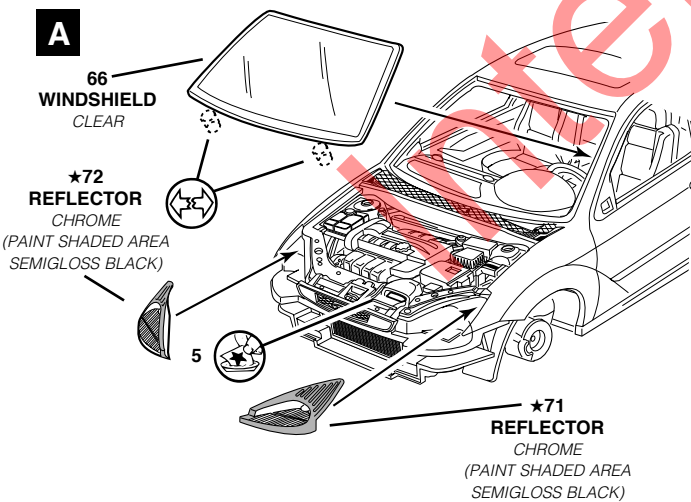

D

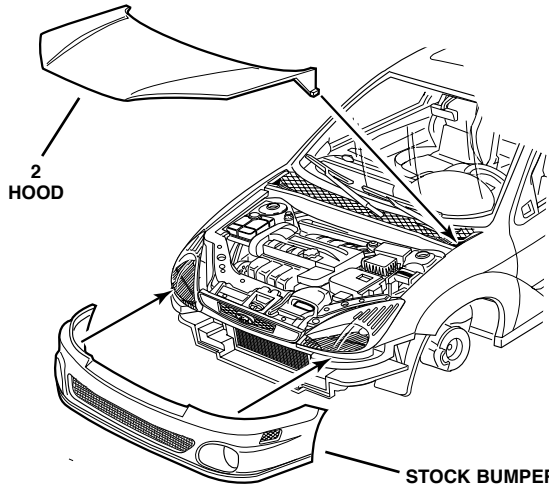
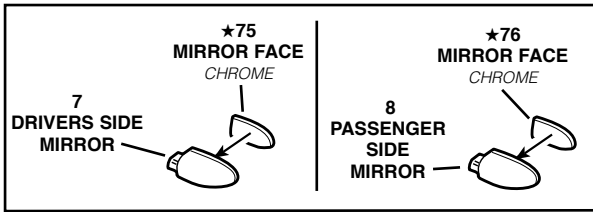

E

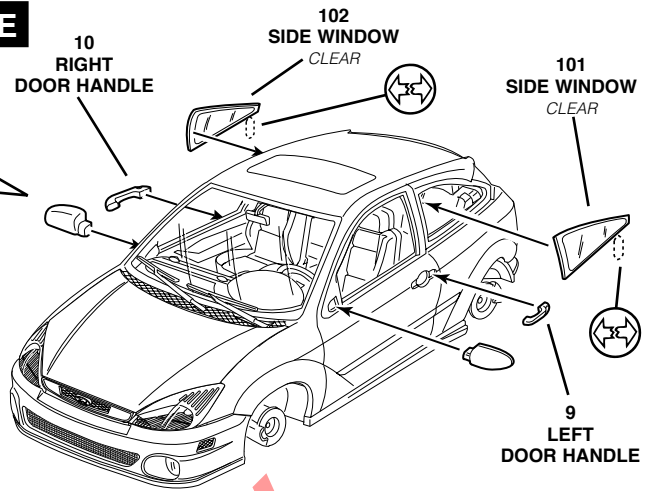

14 CUSTOM SPOILER

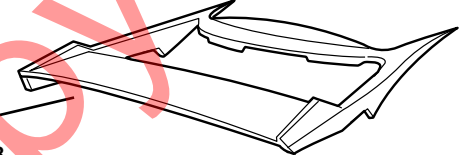

F

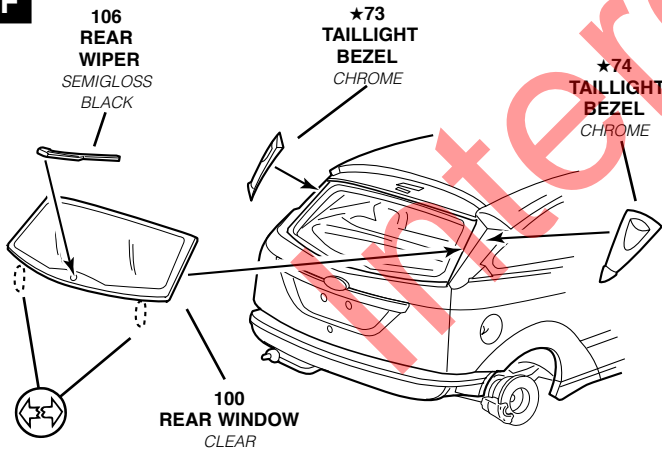

G

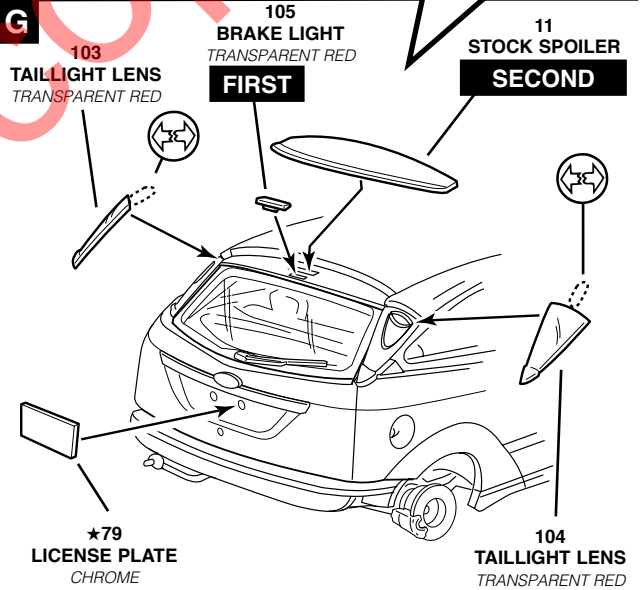

H

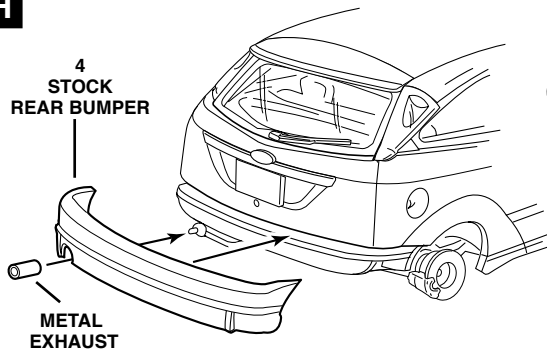

13 CUSTOM REAR BUMPER

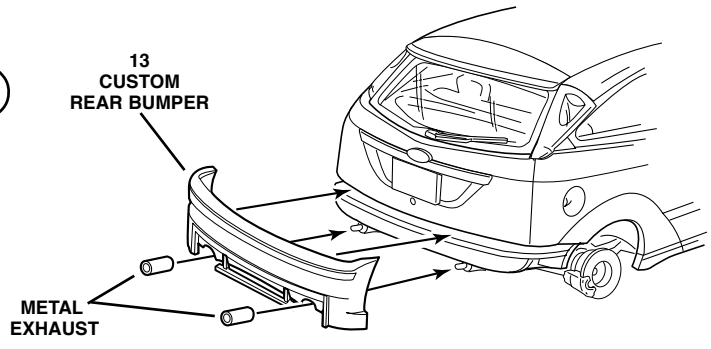

7

WHEEL ASSEMBLY

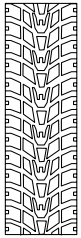
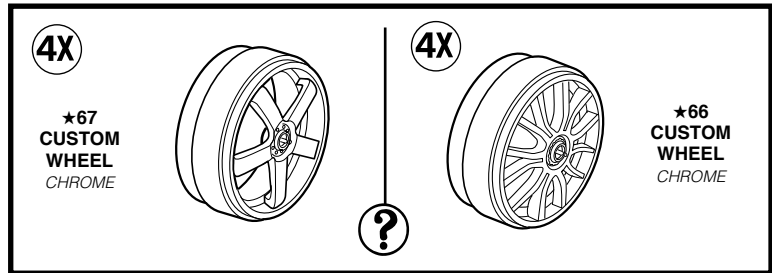
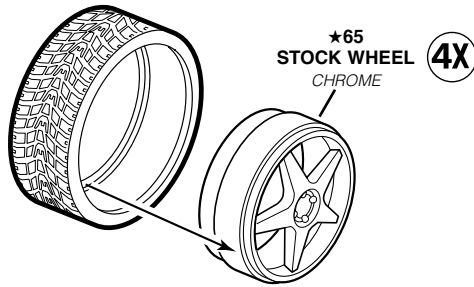

TREAD PATTERN:
V FACES TO THE REAR
ON ALL FOUR

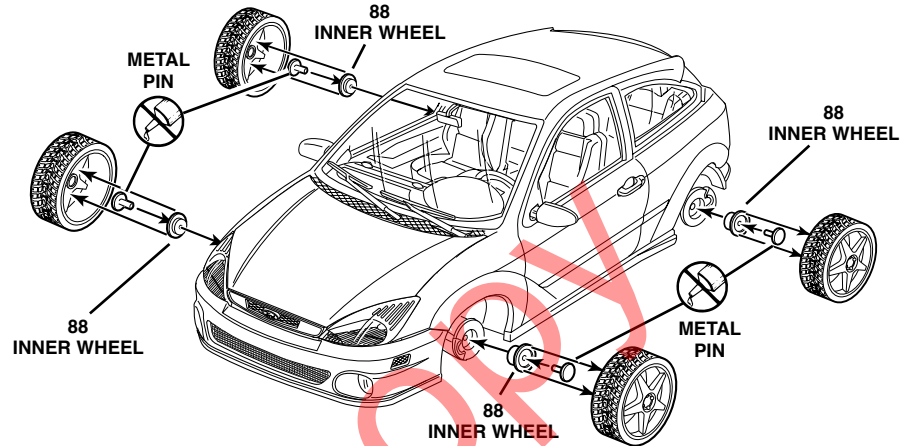

8

DECAL PLACEMENT

NOTE: INSTEAD OF USING DECALS 8, 9, 10 & 11 USE TURN SIGNAL AMBER OVER SILVER

Stock Version

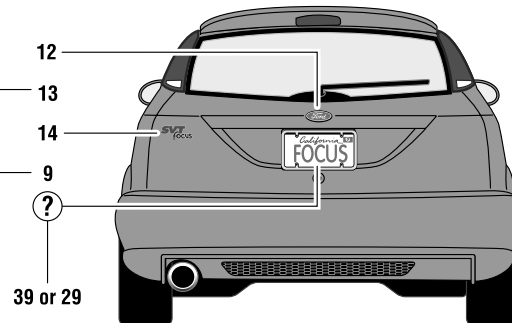
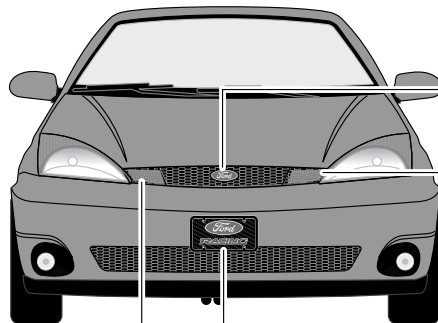
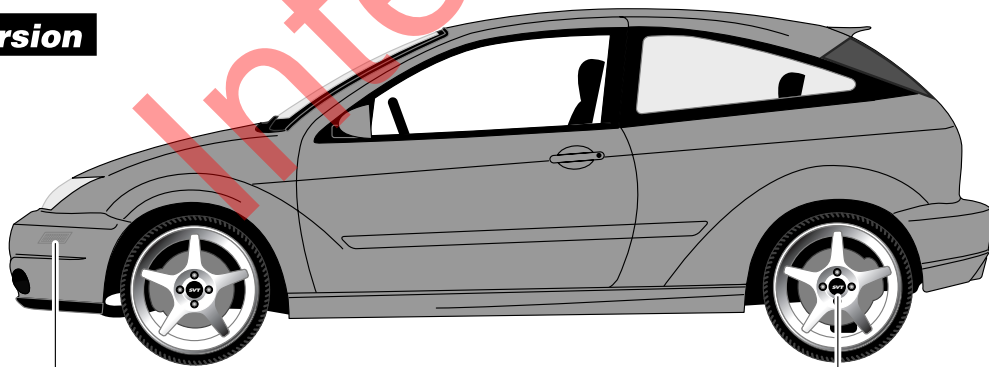

8 ? 38 or 29 (Do not dip in water, carefully cut decal out and use white glue to attach)



NOTE: INSTEAD OF USING DECALS 8, 9, 10 & 11 USE TURN SIGNAL AMBER OVER SILVER

Tuner Version #1

10
(Repeat for other side using #11)

18
(Repeat for other side using #16)

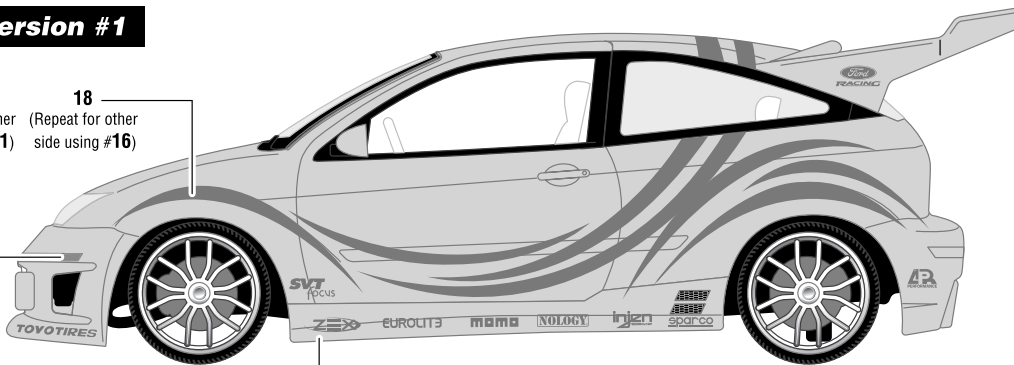

Optional Sponsor Decals
(May be applied to both sides)

6X ?

7
(Apply Hood Pin decals last)

?

20
(Carbon Fiber hood decal can be used with both tuner versions)

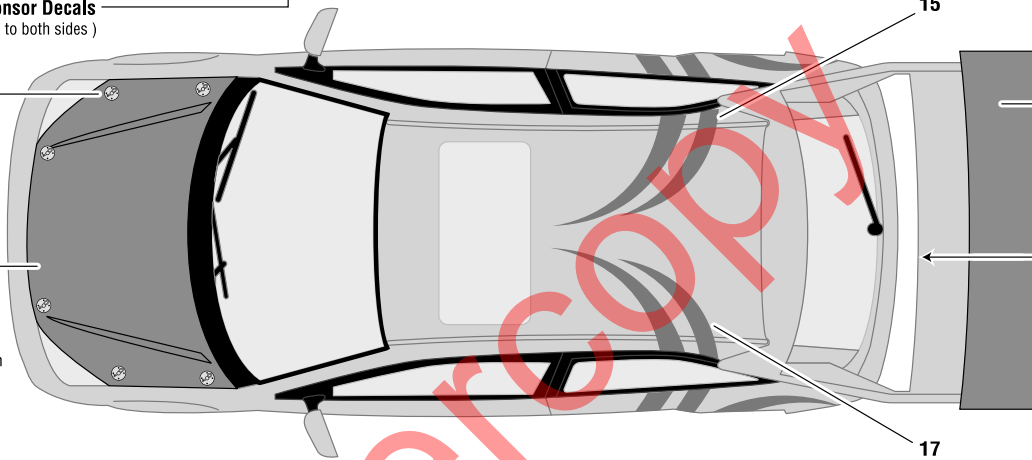

19
(Carbon Fiber hood decal may be used with both tuner versions)

?

Note: Decal will overlap on bottom front section

Note: Slight Curve

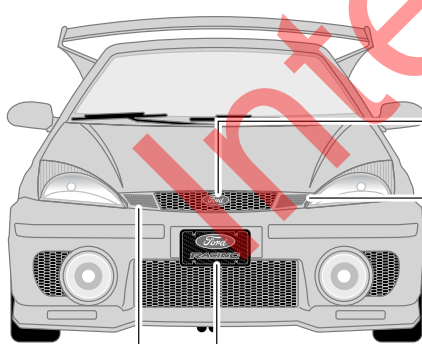

12

13

14

9

?

39 or 29

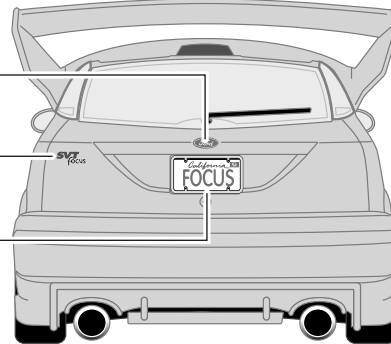

8

?

38 or 29 (Do not dip in water, carefully cut decal out and use white glue to attach)

Tuner Version #2

10
(Repeat for other side using #11)

21
(Repeat for other side using #22)

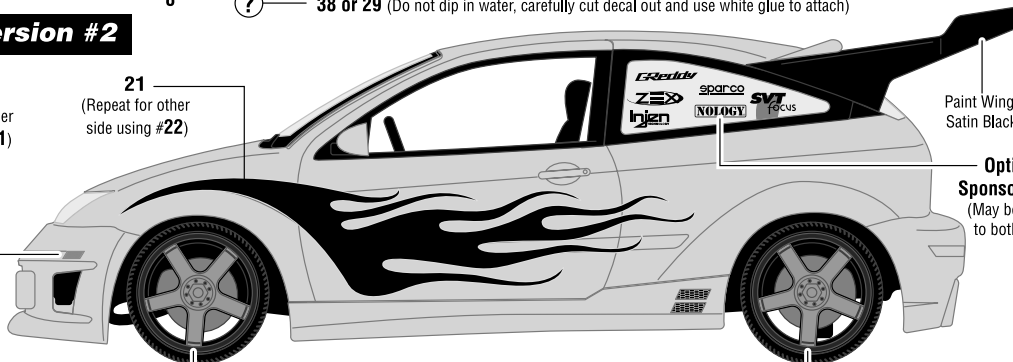

Paint Wing Satin Black

Optional Sponsor Decals
(May be applied to both sides)

Paint Wheels Satin Black