



'85 Fiero GT

The Pontiac Fiero had a history of only five model years-1984 through 1988. Even though over fifteen years have passed since the last Fiero rolled off the production line, the car still has a sizable following of fiercely loyal enthusiasts.

The story behind the Fiero's development actually started with then Pontiac general manager John DeLorean in 1967. Still fresh from the success of the Pontiac GTO™, another car he championed, DeLorean liked the idea of a mid-engined small car with a non-metal body. GM management, already dealing with issues in the development of the already delayed next generation Corvette®, killed the idea.

That's where things stayed until 1978, when the Pontiac division revived the mid-engined car idea. At this time, the US was in the middle of a gasoline shortage and American car manufacturers found themselves low on fuel efficient cars that the public actually wanted to buy. The Fiero was to be positioned as an exciting car that still was an economy car. Names considered at the time for the new car included Pegasus, Sprint and Fiamma, that last name an Italian word that the marketing staff thought would not go over well with the public. Still, when a GM employee stumbled upon "Fiero" in an Italian dictionary (it means "very proud"), everyone gave it a thumbs up.

When the Fiero first appeared in late 1983 as a '84 model, it had but one engine choice, a 2.5 liter 4 cylinder. While many immediately complained

that the car did not have nearly enough power, for many others it was just perfect as it was. While Pontiac hoped to sell 80,000 units in the car's first year, actual sales turned out to be over 100,000, insuring the Fiero's profitability. Another high point was the announcement that the Fiero would be the Pace Car for the following year's Indy 500®, the only mid-engined car and one of the very few 4 cylinder cars to pace the race. In addition, 2,000 Pace Car replicas were offered to the public.

Development moved along quickly after that, with the GT model being introduced early in 1985. The GT, the subject of this Revell kit, included a 2.8 liter V6 engine for more power, larger wheels and tires and the rounded front end that first appeared on the Pace Car. A year later, the fastback body style was introduced.

Things took a strange turn in the 1988 model year. Many thought the '88s were the best Fieros yet and new colors and options including leather interior and the rare T-Tops (only 1,250 built) were made available. A prototype '89 model was even built. Yet, GM discontinued the Fiero suddenly after the 1988 models. To this day, many Fiero enthusiasts debate as to why the car was dropped. The last two Fieros were produced on August 16, 1988 and were both given to employees at the plant. The Fiero story didn't end on that day, however, and many clubs and companies offering parts and technical assistance still abound.



* REPEAT SEVERAL TIMES
* A REPETER PLUSIEURS FOIS



* OPTIONAL PARTS
* PIECES EN OPTION



* DECAL
* DECAL COMANIE



* ALTERNATIVE ASSEMBLY
* ENSEMBLAGE ALTERNATIVE



* CEMENT TOGETHER
* A COLLER



* REMOVE AND THROW AWAY
* A RETIRER ET JETER



* DO NOT CEMENT
* NE PAS COLLER

READ THIS BEFORE YOU BEGIN

- * Study the assembly drawings.
- * Each plastic part is identified by a number.
- * In the assembly drawings, some parts will be marked by a star (★) to indicate chrome plated plastic.
- * For better paint and decal adhesion, wash the plastic parts in a mild detergent solution. Rinse and let air dry.
- * Check the fit of each piece before cementing in place.
- * Use only cement for polystyrene plastic.
- * Scrape plating and paint from areas to be cemented.
- * Allow paint to dry thoroughly before handling parts.
- * Any unused parts may be discarded.

DECAL APPLICATION INSTRUCTIONS

1. Cut desired decal from sheet.
2. Dip decal in water for a few seconds.
3. Place wet decal on paper towel.
4. Wait until decal is movable on paper backing.
5. Place decal in position on model, face up and slide backing away.
6. Press out air bubbles with a soft damp cloth.
7. Milkiness that may appear is for better decal adhesion and will dry clear. Wipe away any excess adhesive.
8. Do not touch decal until fully dry.
9. Allow the decals 48 hours to dry before applying clear coat.

NOTE: Decals are compatible with setting solutions or solvents.

LIRE CE QUI SUIT AVANT DE COMMENCER

- * Etudier les schémas de montage.
- * Chaque pièce en plastique est identifiée par un numéro.
- * Sur les schémas de montage, certaines pièces sont marquées d'une étoile (★) pour indiquer qu'elles sont en plastique chromé.
- * Pour une meilleure prise de la peinture et des autocollants, laver les pièces en plastique avec une solution détergente peu concentrée. Les rincer et les laisser sécher à l'air.
- * Vérifier que chaque pièce s'ajuste bien avant de la coller en place.
- * N'utiliser que de la colle pour polystyrène.
- * Gratter les parties à coller pour enlever le chrome et la peinture.
- * Laisser la peinture bien sécher avant de manipuler les pièces.
- * Toute pièce inutilisée peut être jetée.

DIRECTIVES D'APPLICATION DES AUTOCOLLANTS

1. Découper l'autocollant désiré de la feuille.
2. Tremper l'autocollant dans de l'eau pendant quelques secondes.
3. Placer l'autocollant mouillé sur une serviette en papier.
4. Attendez que l'autocollant puisse être déplacé sur son support en papier.
5. Mettre l'autocollant en position sur le modèle face sur le dessus et faire glisser le support pour l'enlever.
6. Appuyer avec un chiffon doux humide pour éliminer les bulles d'air.
7. La substance laiteuse qui peut apparaître est destinée à améliorer l'adhésion de l'autocollant et devient incolore au séchage. Essuyer pour enlever tout excédent d'adhésif.
8. Ne pas toucher l'autocollant tant qu'il n'est pas bien sec.
9. Laisser l'autocollant sécher pendant 48 heures avant d'appliquer une couche transparente.

REMARQUE: Les autocollants sont compatibles avec les solutions de fixation ou les solvants.

This optional paint guide is provided if you choose to detail paint your model.

Ce guide de peintures vous sera fourni si vous choisissez de peindre votre modèle en détail.

Aluminum	<i>Aluminium</i>
Flat Black	<i>Noir mat</i>
Gloss Black	<i>Noir brillant</i>
Red	<i>Rouge</i>
Silver	<i>Argent</i>
Steel	<i>Acier</i>
Tan	<i>Havane</i>
Transparent Red	<i>Transparent Red</i>
Turn Signal Amber	<i>Feu clignotant de direction ambre</i>
White	<i>Blanc</i>

If you have any questions or comments, call our hotline at: **(800) 833-3570** or, please write to:

Revell-Monogram Consumer Service Department, 725 Landwehr Road, Northbrook, Illinois 60062

Be sure to include the plan number (85224200200), part number, description, your return address and phone number.

Visit our website: www.revellmonogram.com

1

ENGINE ASSEMBLY

A

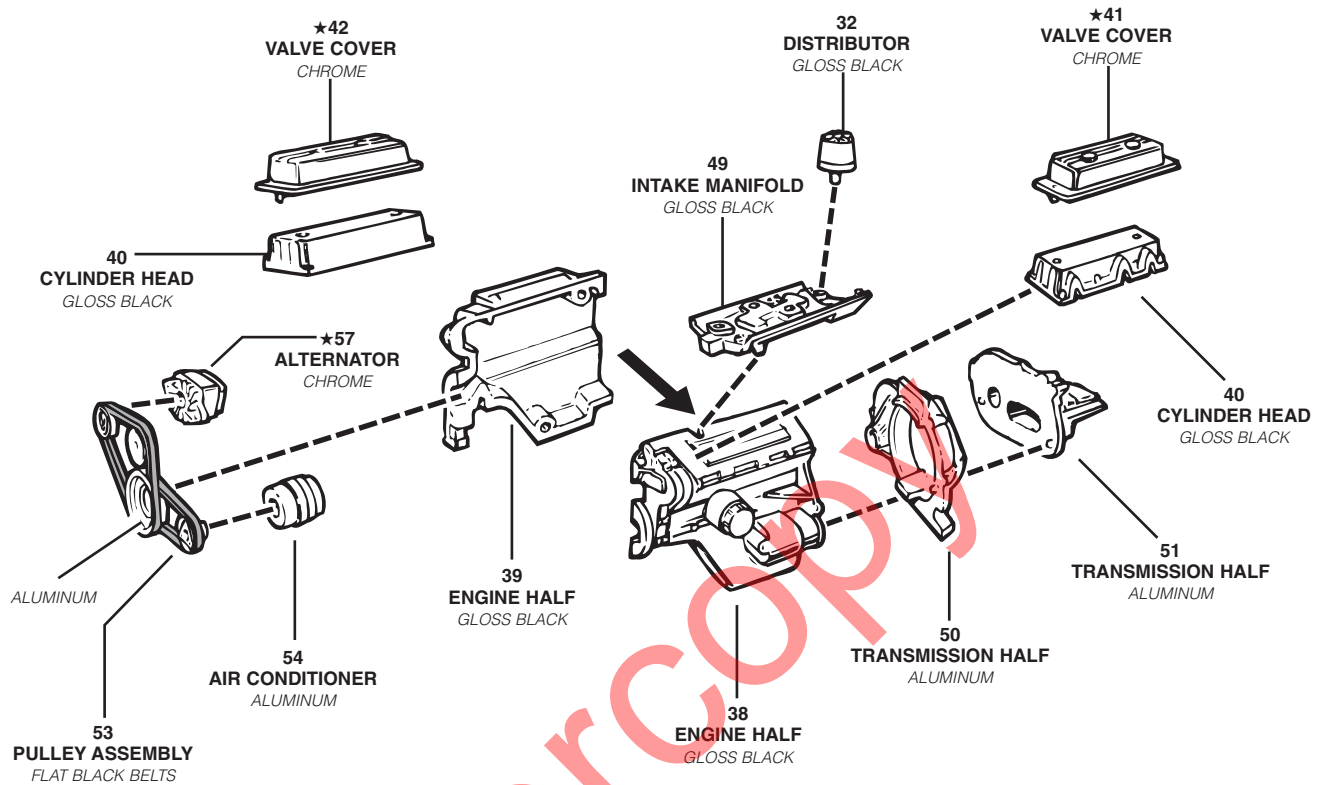

B

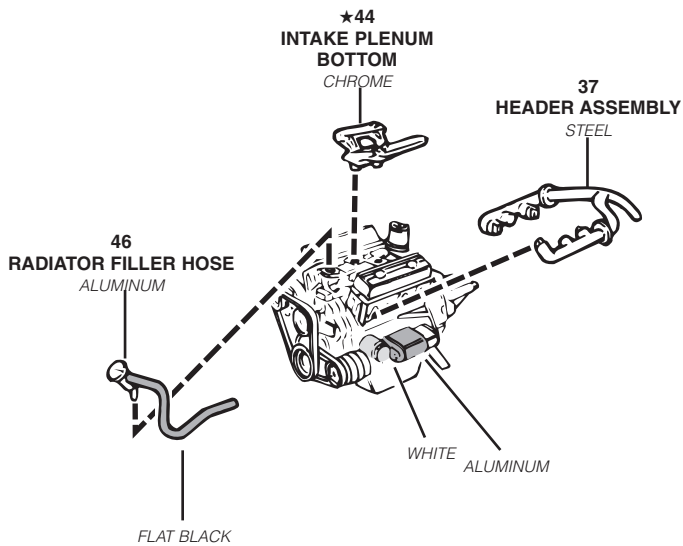

C

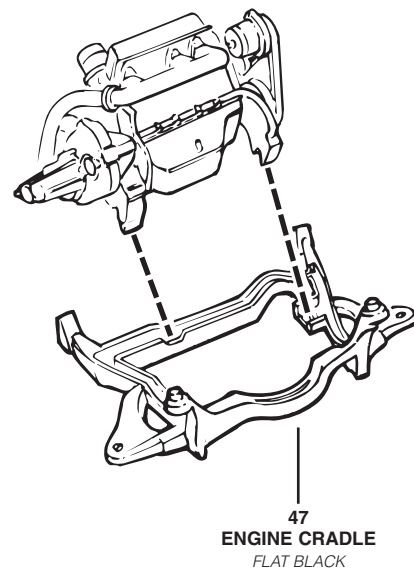

2

REAR CHASSIS ASSEMBLY

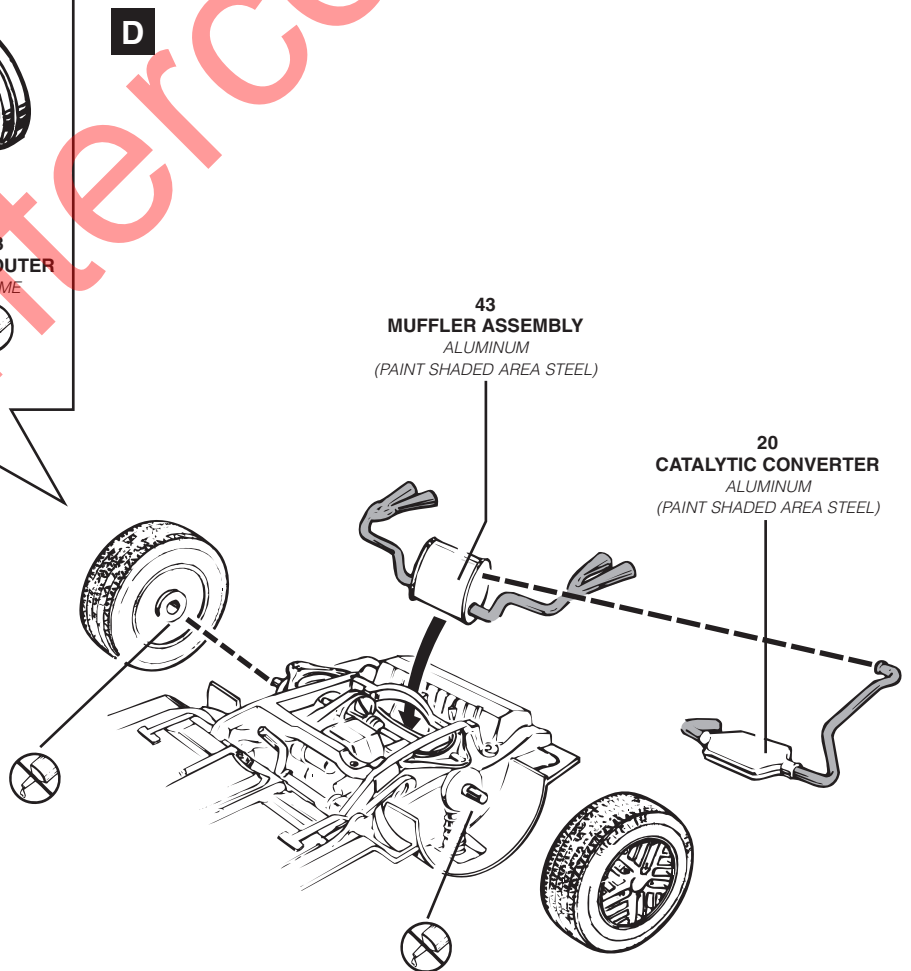
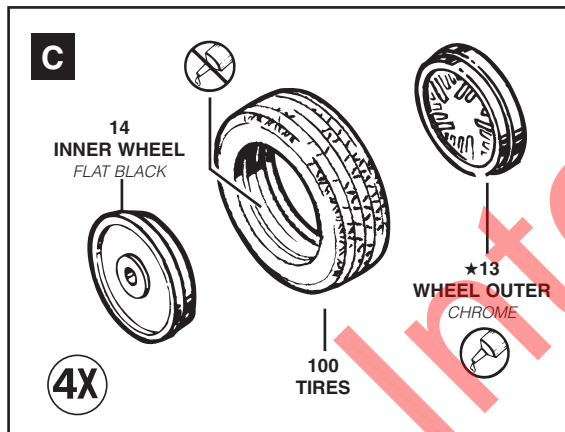
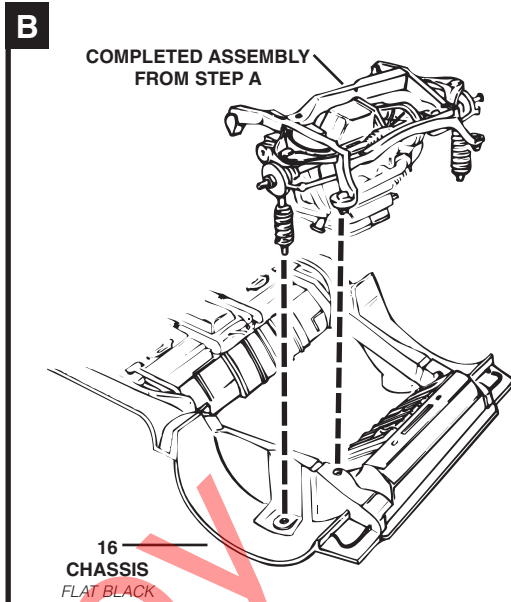
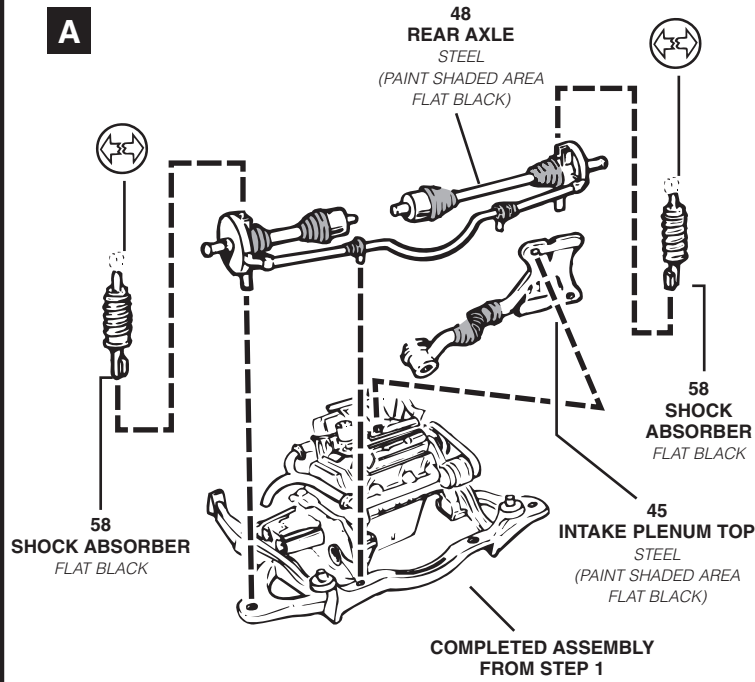

3

FRONT CHASSIS ASSEMBLY

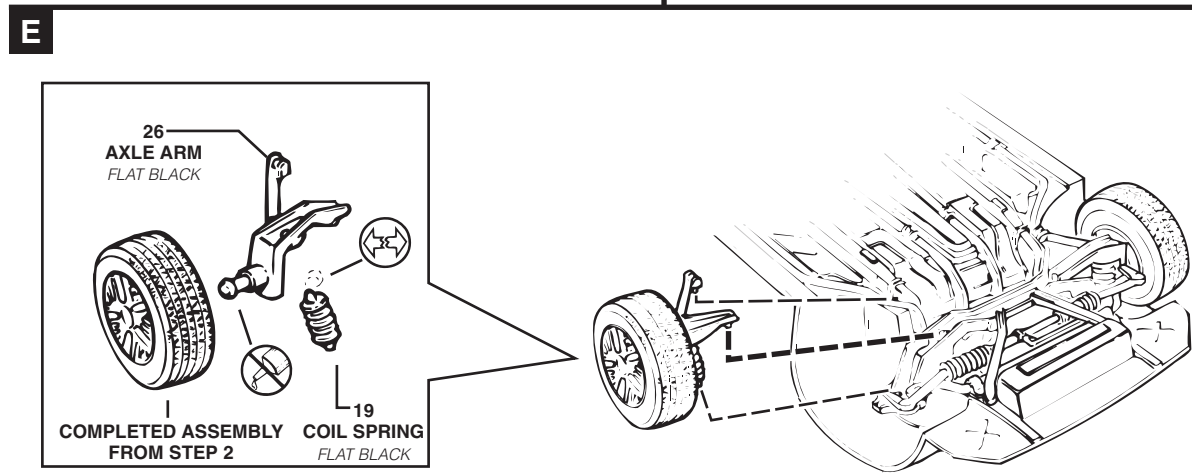
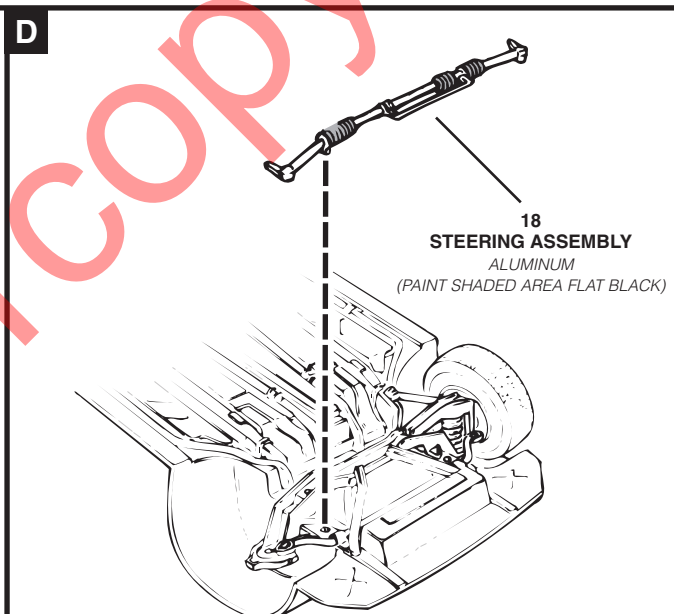
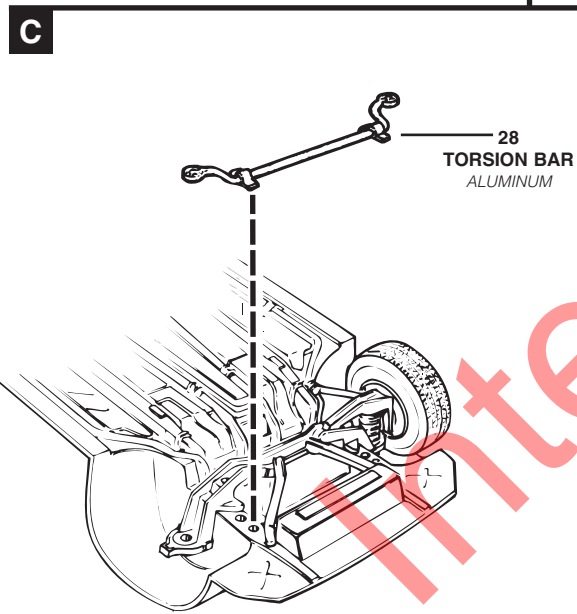
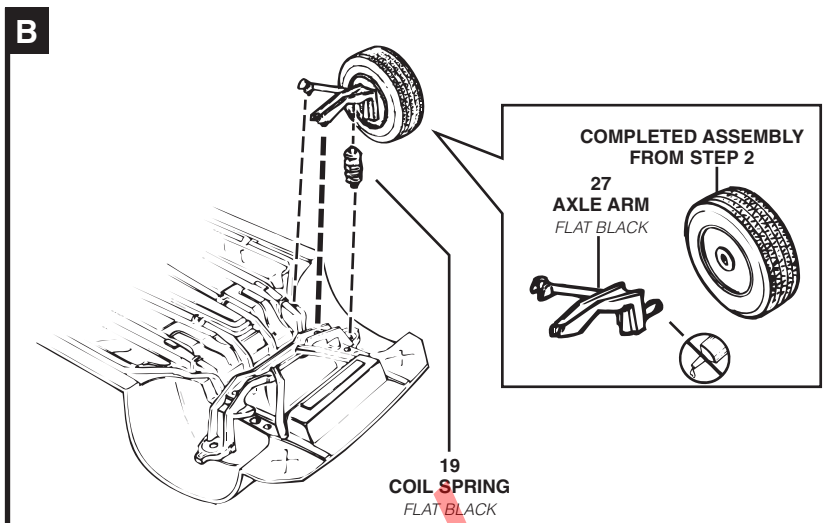
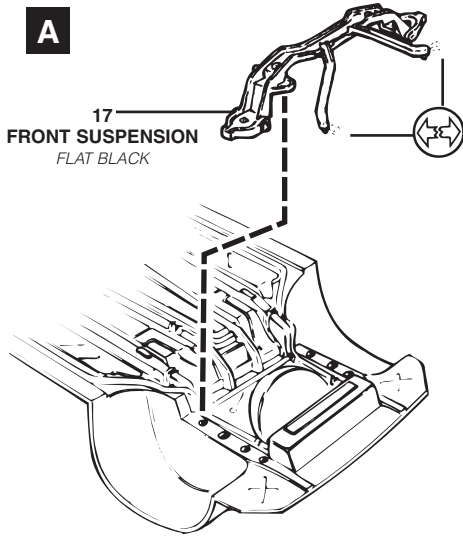

4

INTERIOR ASSEMBLY

A

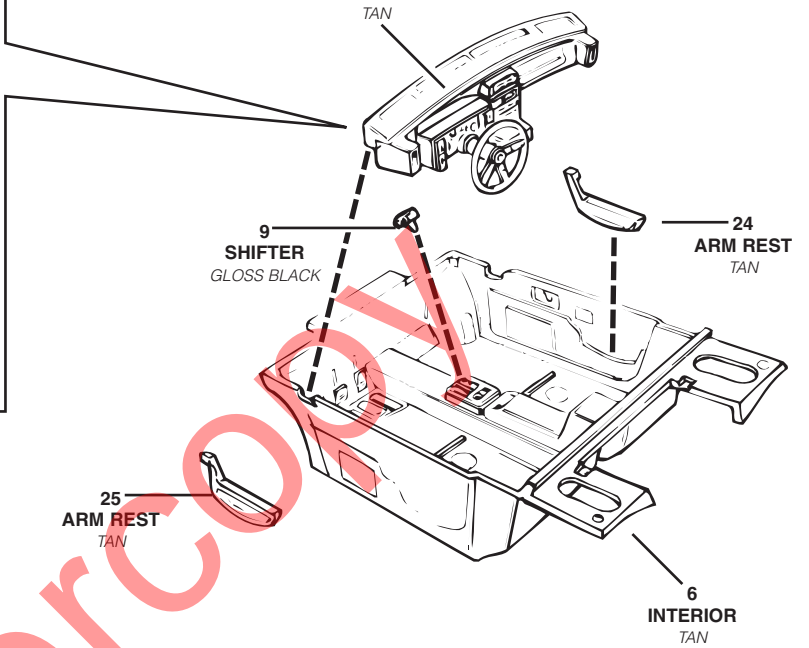
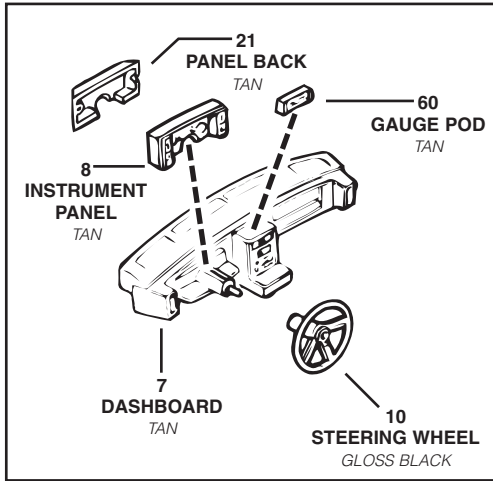

B

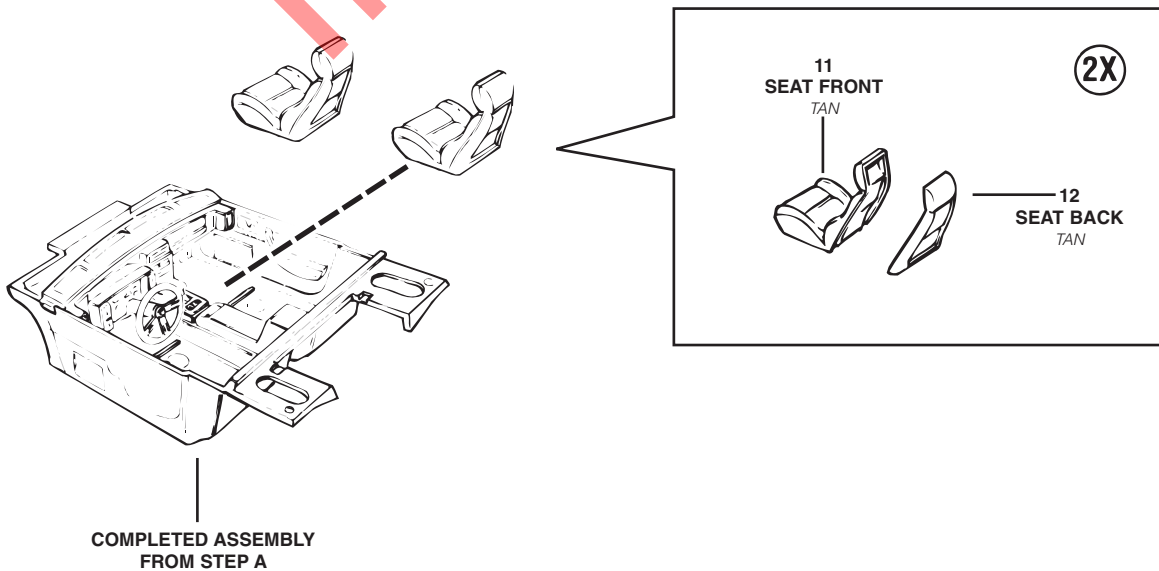

5

BODY ASSEMBLY

A

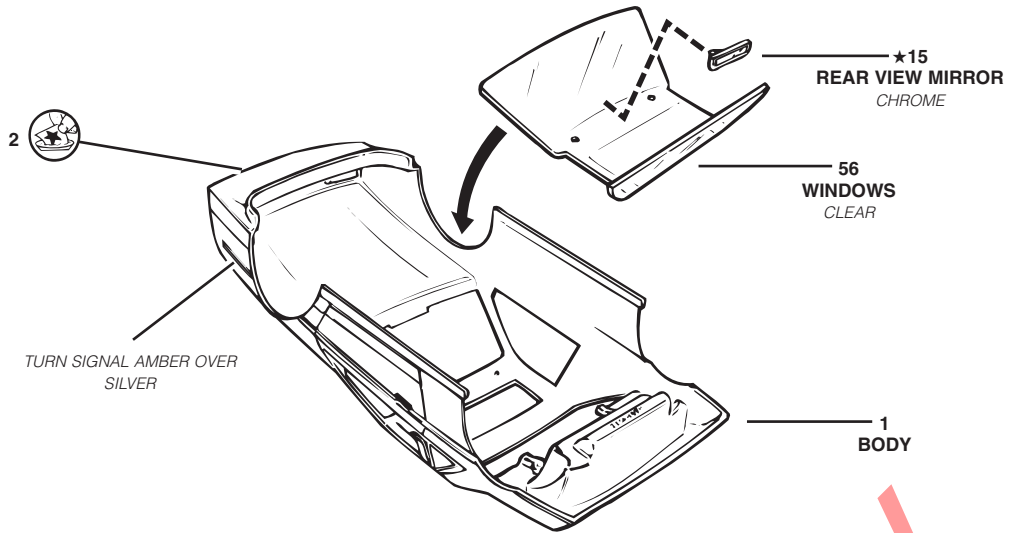

B

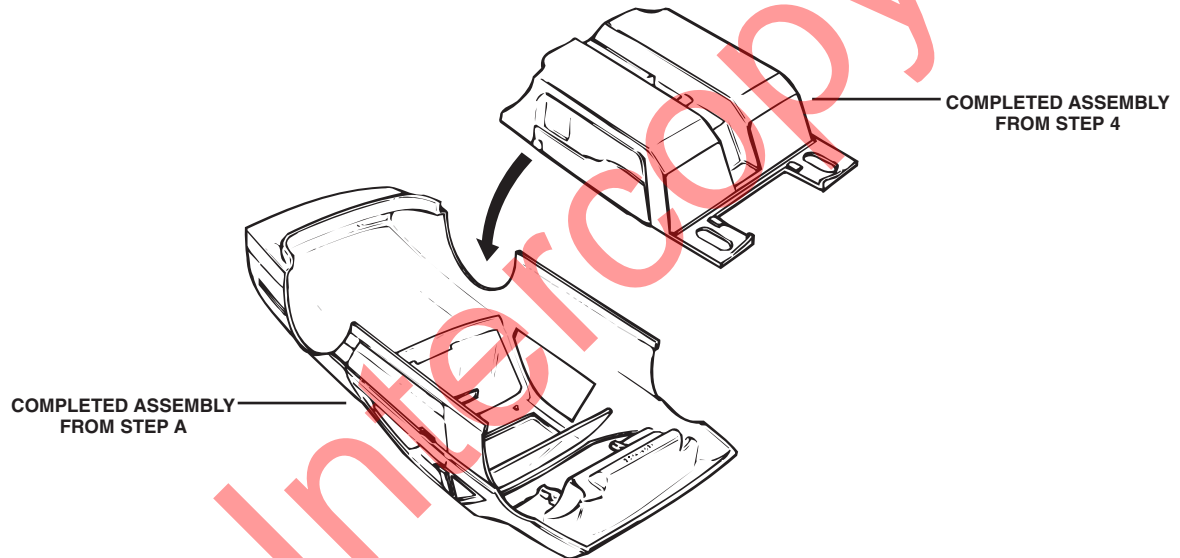

C

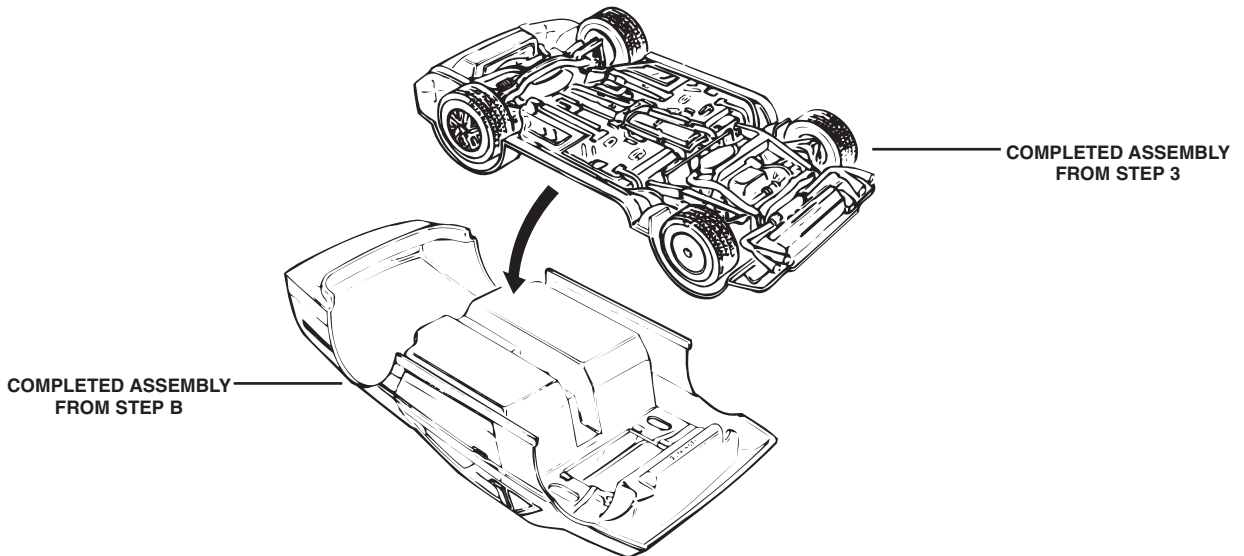

6

REAR BODY ASSEMBLY

A

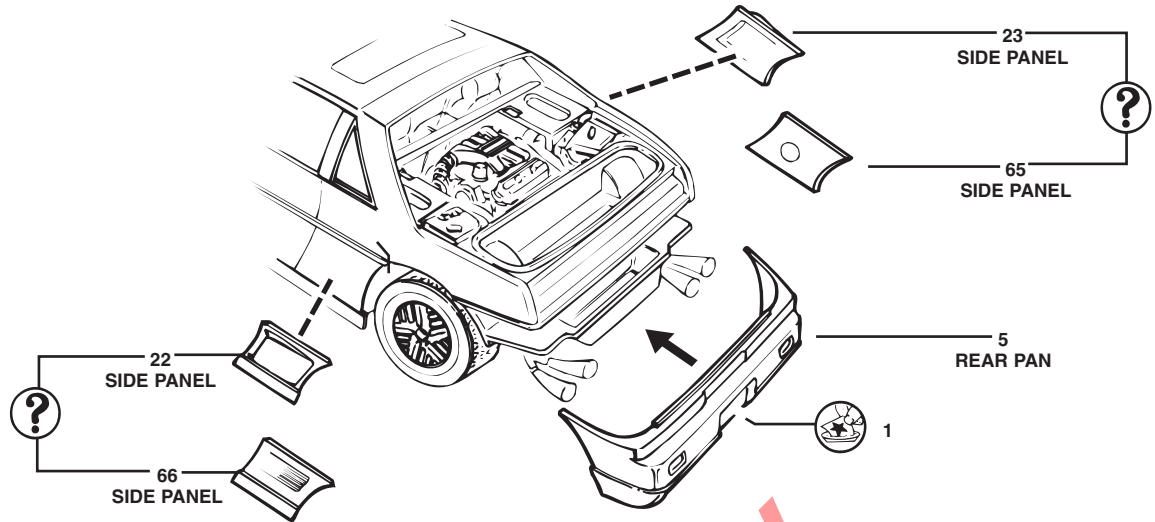

B

