



KIT 2375



DALE EARNHARDT GOODWRENCH SERVICE PLUS® 2001 MONTE CARLO™ STOCK CAR

85237500200

Historians may discover that Dale Earnhardt will remain NASCAR's all-time greatest driver of the Modern Era, (since 1971). His record of seventy six career wins, 281 top five and 428 top ten finishes, including twenty two pole position starts en route to seven NASCAR Cup Championships might not ever be exceeded. He scored his only Daytona 500 victory, a race the sports media calls "The Superbowl of Stock Car Racing" in the Fiftieth Anniversary Year of NASCAR at Daytona, Florida; the birthplace of NASCAR.

His record at Daytona is remarkable. Dale Earnhardt was, after 1997, the single most successful driver at Daytona since King Richard Petty. Dale won over four million dollars there; more money than any other driver in NASCAR history. He was a two-time winner of the Pepsi 400, held on the Independence Day weekend every July. Dale won the Clash, now hailed as the Shootout; the sprint race for past year pole winners, six times. Dale has won in the International Race of Champions (IROC) at Daytona. Since 1990, Earnhardt had been victorious in his half of the Twin 125 Qualifiers, weekday races that set the field for Sunday's Daytona 500, every time he entered until 2000, when the Fords shut him out.

In 1998, when Earnhardt entered the fortieth running of the Daytona 500 there were doubts. After a slim 1997 season, many expected not to see him capture the checkered flag. Richard Childress Racing was prepared for victory however, as the GM Goodwrench Service Plus Team, led by the former Daytona 500 winning crew chief Larry McReynolds had all tested well, helping Dale to win yet another Twin 125 Qualifier. On Sunday, they ran strong and avoided all the trouble on the race track. There was plenty of that, the race in fact ended under caution, with the #3 car first to the yellow flag with only a few laps to go. On his way to Victory Lane, Earnhardt was applauded by every single team on pit row, and crew after crew came out to congratulate him. No one will forget Speedweeks 1998, when Dale Earnhardt and the Goodwrench team won their first Daytona 500.

Your Revell kit depicts Dale's Chevrolet as it appeared for the 2001 Daytona 500, or as it appeared in the 2001 shootout with Oreo graphics to fit the most recent Monte Carlo body shell, having the latest roof and cowl flaps, flush right-side window, vented front air dam, side skirt extensions and jack posts. Quarter windows have circulation vents, connecting to a network of four interior mounted cooling air duct hoses. The body will lift off to reveal a superspeedway chassis, with single-shock suspension, belt driven oil recirculation pumps on both engine and rear end, inboard mounted oil tank, contoured driver's seat, and an full perimeter roll cage. It rides on Aero eight-hole racing wheels and Goodyear radial slicks. Detail include interior roll bar padding, making this a true state-of-the-art stock car replica.



up-to-date engine water hoses, and



*** REPEAT SEVERAL TIMES**
* A REPETER PLUSIEURS FOIS



*** OPTIONAL PARTS**
* PIECES EN OPTION



*** DECAL**
* DECAL COMANIE



*** ALTERNATIVE ASSEMBLY**
* ENSEMBLAGE ALTERNATIVE



*** CEMENT TOGETHER**
* A COLLER



*** REMOVE AND THROW AWAY**
* A RETIRER ET JETER



*** DO NOT CEMENT**
* NE PAS COLLER

READ THIS BEFORE YOU BEGIN

- * Study the assembly drawings.
- * Each plastic part is identified by a number.
- * In the assembly drawings, some parts will be marked by a star (★) to indicate chrome plated plastic.
- * For better paint and decal adhesion, wash the plastic parts in a mild detergent solution. Rinse and let air dry.
- * Check the fit of each piece before cementing in place.
- * Use only cement for polystyrene plastic.
- * Scrape plating and paint from areas to be cemented.
- * Allow paint to dry thoroughly before handling parts.
- * Any unused parts may be discarded.

DECAL APPLICATION INSTRUCTIONS

1. Cut desired decal from sheet.
2. Dip decal in water for a few seconds.
3. Place wet decal on paper towel.
4. Wait until decal is movable on paper backing.
5. Place decal in position on model, face up and slide backing away.
6. Press out air bubbles with a soft damp cloth.
7. Milkyness that may appear is for better decal adhesion and will dry clear. Wipe away any excess adhesive.
8. Do not touch decal until fully dry.
9. Allow the decals 48 hours to dry before applying clear coat.

NOTE: Decals are not compatible with setting solutions or solvents.

LIRE CE QUI SUIT AVANT DE COMMENCER

- * Etudier les schémas de montage.
- * Chaque pièce en plastique est identifiée par un numéro.
- * Sur les schémas de montage, certaines pièces sont marquées d'une étoile (★) pour indiquer qu'elles sont en plastique chromé.
- * Pour une meilleure prise de la peinture et des autocollants, laver les pièces en plastique avec une solution détergente peu concentrée. Les rincer et les laisser sécher à l'air.
- * Vérifier que chaque pièce s'ajuste bien avant de la coller en place.
- * N'utiliser que de la colle pour polystyrène.
- * Gratter les parties à coller pour enlever le chrome et la peinture.
- * Laisser la peinture bien sécher avant de manipuler les pièces.
- * Toute pièce inutilisée peut être jetée.

DIRECTIVES D'APPLICATION DES AUTOCOLLANTS

1. Découper l'autocollant désiré de la feuille.
2. Tremper l'autocollant dans de l'eau pendant quelques secondes.
3. Placer l'autocollant mouillé sur une serviette en papier.
4. Attendez que l'autocollant puisse être déplacé sur son support en papier.
5. Mettre l'autocollant en position sur le modèle face sur le dessus et faire glisser le support pour l'enlever.
6. Appuyer avec un chiffon doux humide pour éliminer les bulles d'air.
7. La substance laiteuse qui peut apparaître est destinée à améliorer l'adhésion de l'autocollant et devient incolore au séchage. Essuyer pour enlever tout excédent d'adhésif.
8. Ne pas toucher l'autocollant tant qu'il n'est pas bien sec.
9. Laisser l'autocollant sécher pendant 48 heures avant d'appliquer une couche transparente.

This paint guide is provided to complete this kit as shown on the box.

Ce guide de peinture est fourni pour reproduire le modèle réduit qui apparaît sur la boîte.

| | |
|-------------|--------------|
| Aluminum | Aluminum |
| Flat Black | Noir mat |
| Gloss Black | Noir lustré |
| Gloss Red | Rouge lustré |
| Light Gray | Gris clair |
| Satin Black | Noir satin |
| Silver | Argent |
| Steel | Acier |
| Yellow | Jaune |

If you have any questions or comments, call our hotline at: (800) 833-3570 or, please write to:

Revell-Monogram Consumer Service Department, 8601 Waukegan Road, Morton Grove, Illinois 60053
Be sure to include the plan number (85237500200), part number, description, your return address and phone number.

Visit our website: www.revell-monogram.com

1

ENGINE ASSEMBLY

A * NOTE: BEND PLUG WIRES SO THAT LONG TABS ON WIRES FIT INTO DEPRESSIONS ON CYLINDER HEADS

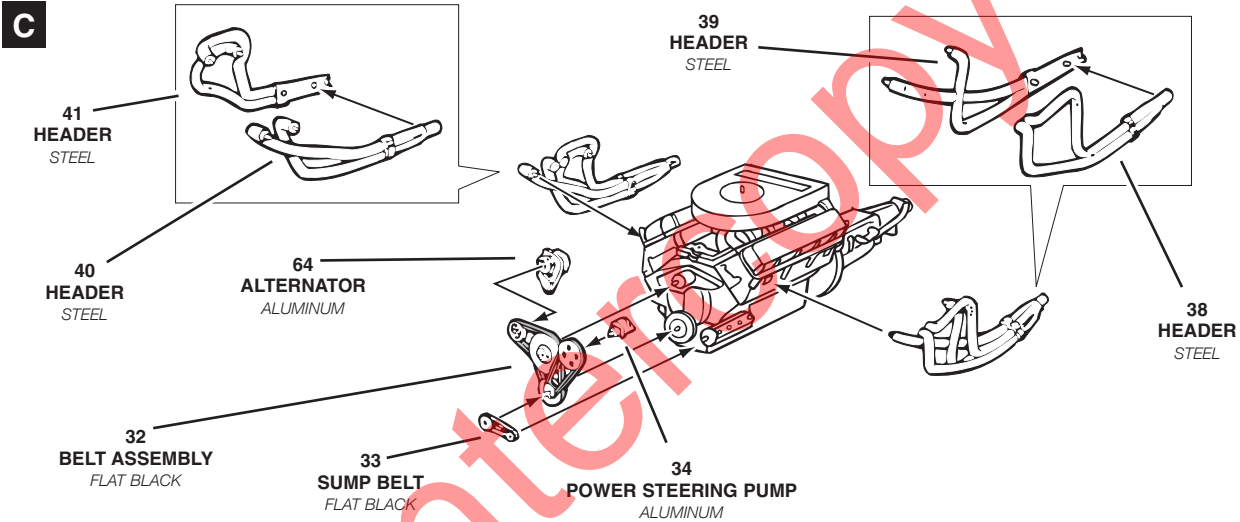
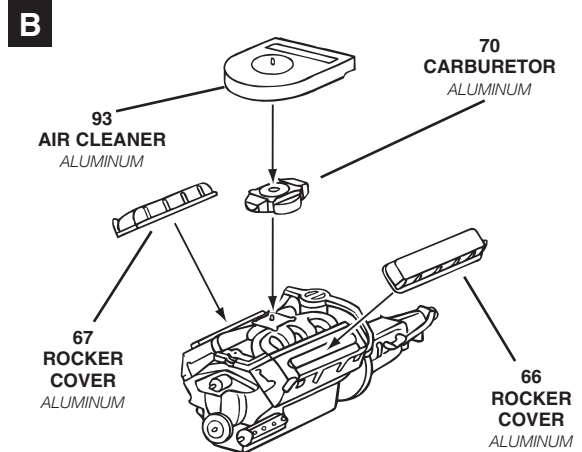
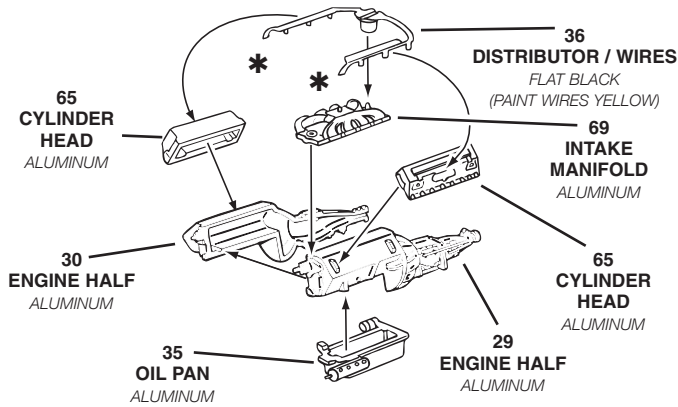

2

CHASSIS / INTERIOR ASSEMBLY

A NOTE: LEAVE SUPPORT STRAP IN PLACE UNTIL STEP 4A

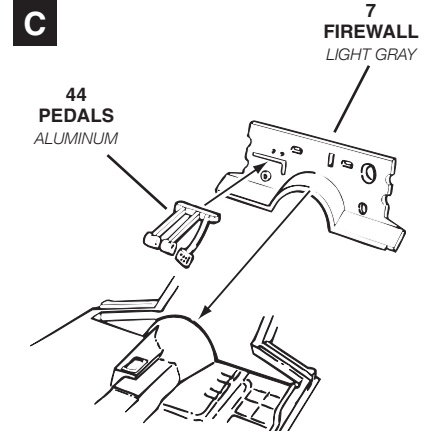
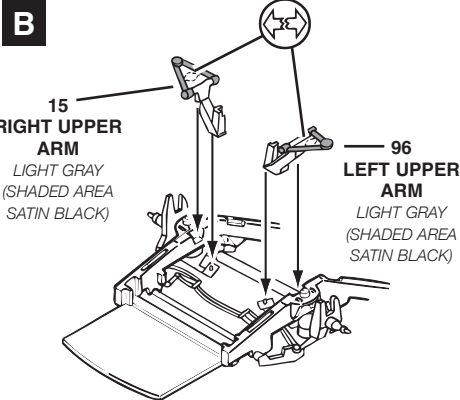
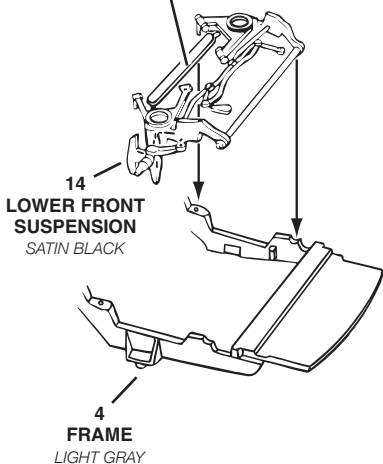

2

CHASSIS / INTERIOR ASSEMBLY CONTINUED

D

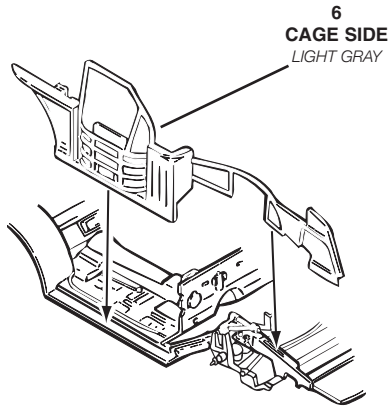

E

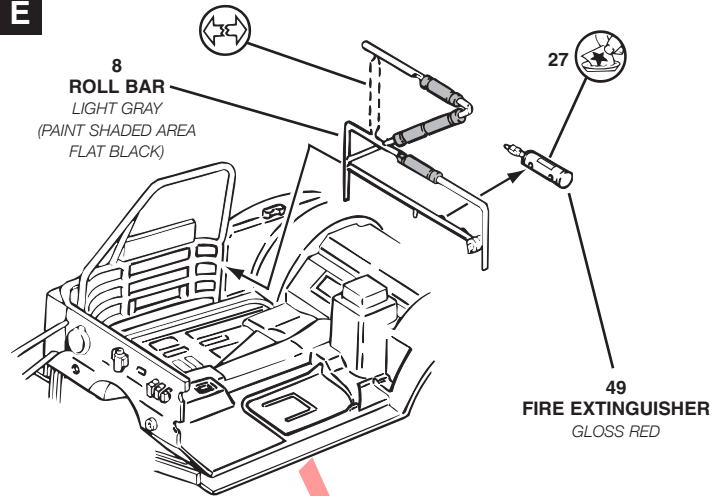

F

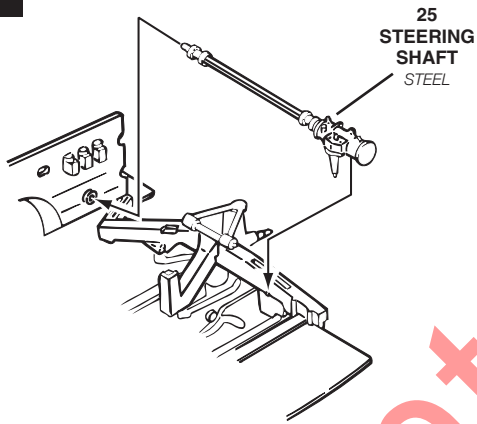

G

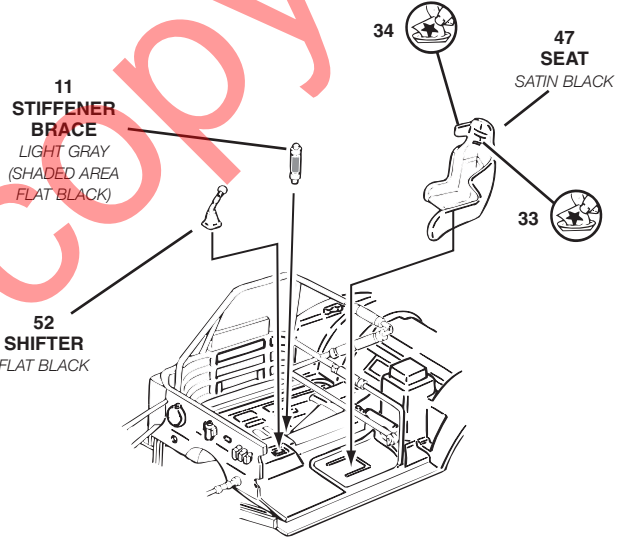

H

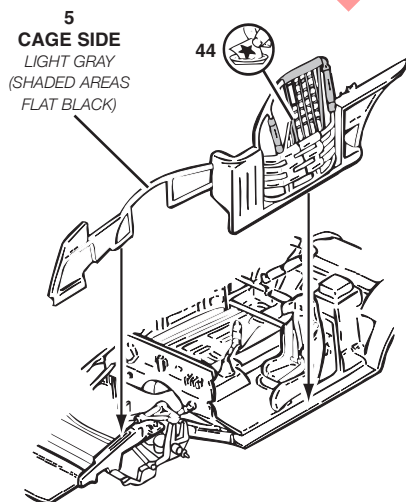

I

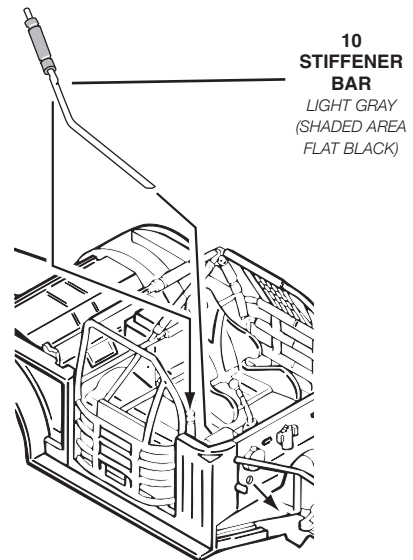

2

CHASSIS / INTERIOR ASSEMBLY CONTINUED

J

57
PETTY BAR
LIGHT GRAY

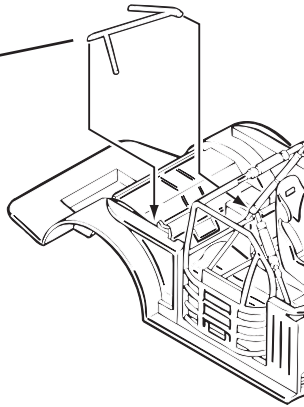

K

50
HOSE
FLAT BLACK

48
HOSE
FLAT BLACK

51
HOSE
FLAT BLACK

61
HOSE
FLAT BLACK

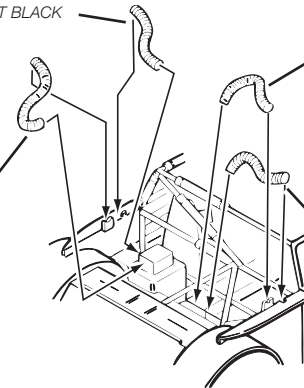

L

73
TOP STIFFENER BAR
LIGHT GRAY
(SHADED AREA FLAT BLACK) **FIRST**

9
TOP BRACE
LIGHT GRAY
(SHADED AREA
FLAT BLACK)
SECOND

72
MIRROR
FLAT BLACK
(MIRROR FACE SILVER)

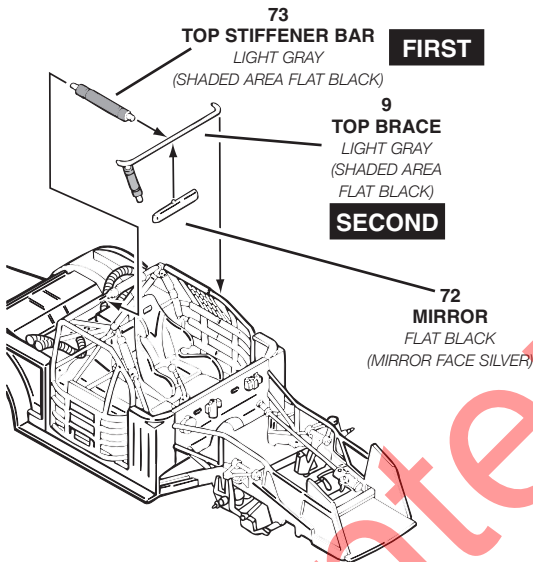

M

56
REAR SHELF
LIGHT GRAY
THIRD

12
KICKER BAR
ASSEMBLY
LIGHT GRAY
SECOND

13
FUEL CELL
LIGHT GRAY
(PAINT SHADED
AREA ALUMINIUM)
FIRST

92
REAR SUSPENSION
ADJUSTMENT TUBES
LIGHT GRAY

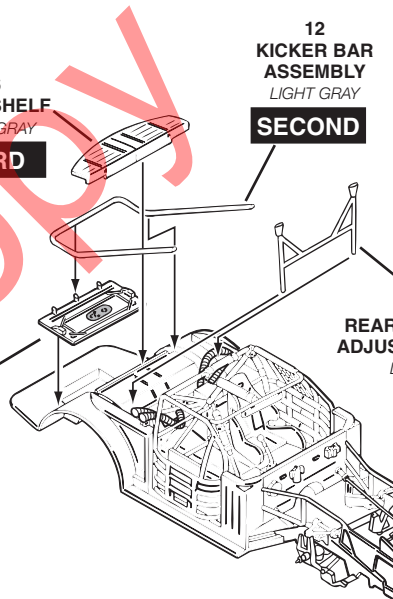

3

SUSPENSION / CHASSIS ASSEMBLY

A

59
OILER TANK
ALUMINIUM

22
SHOCK ASSEMBLY
LIGHT GRAY
(SHADED AREA ALUMINIUM)

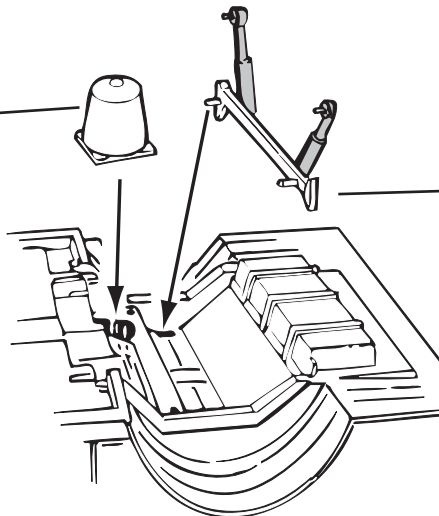

3

SUSPENSION / CHASSIS ASSEMBLY CONTINUED

B

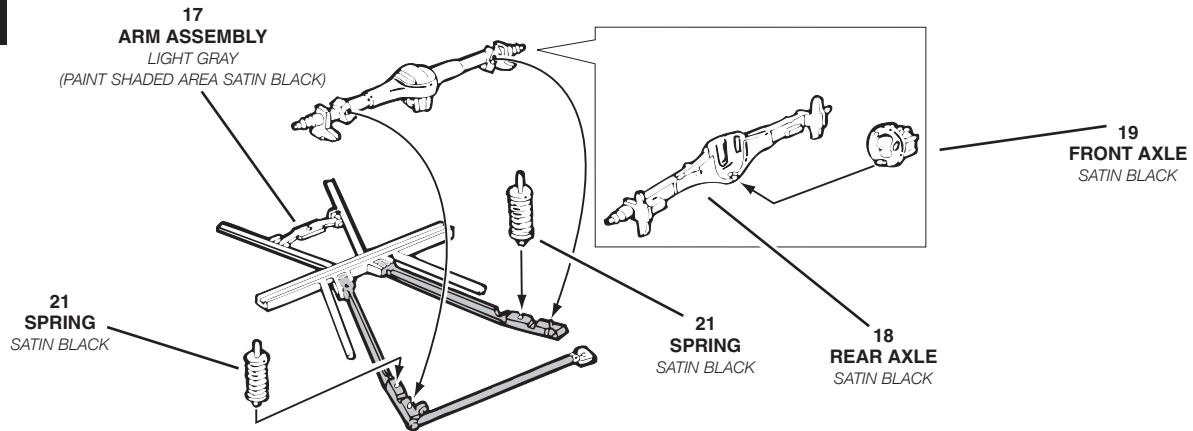

C

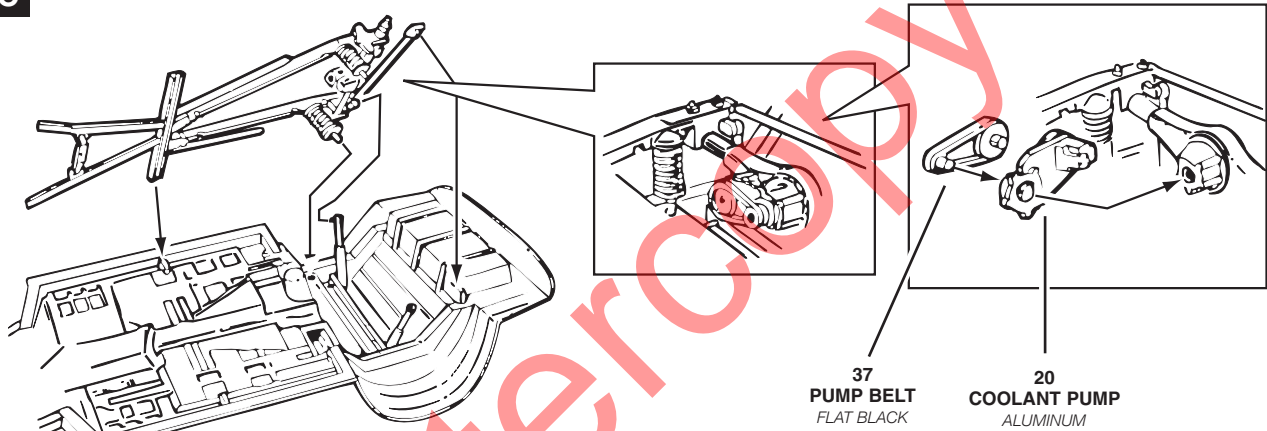

4

CHASSIS DETAIL ASSEMBLY

A

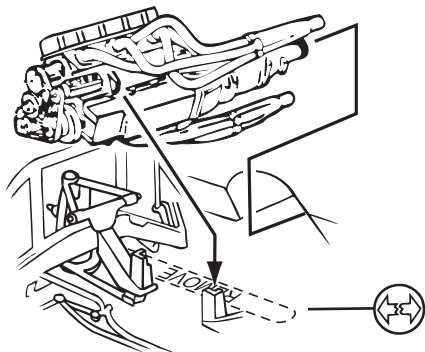

B

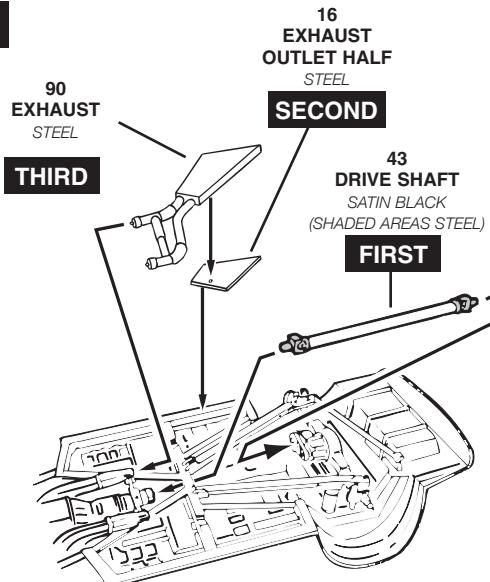

C

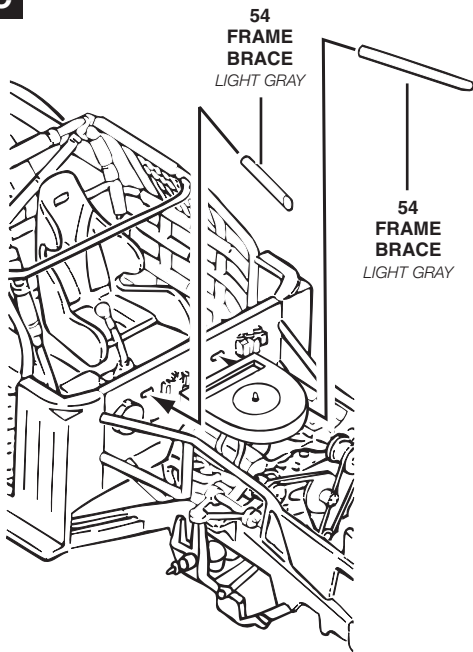

D

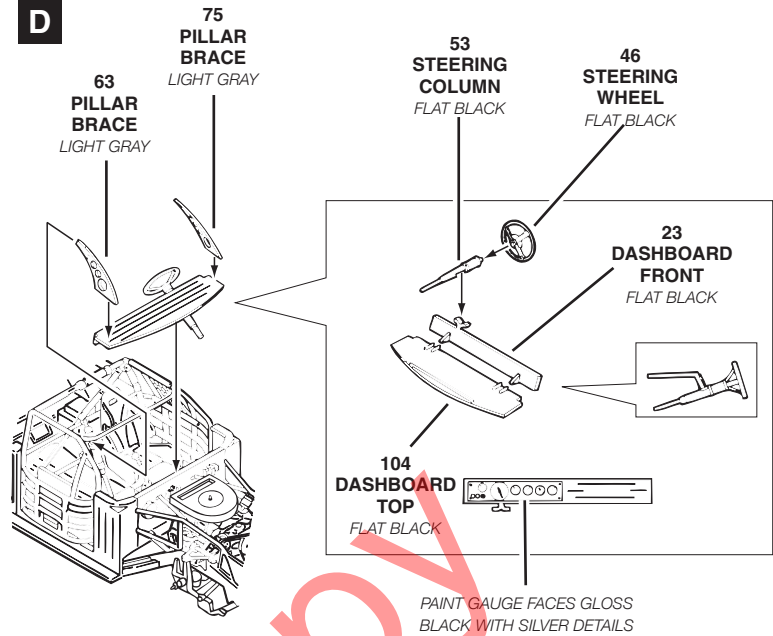

E

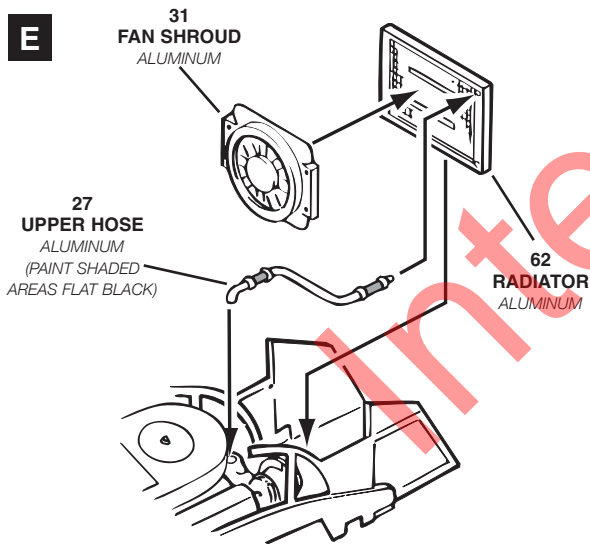

F

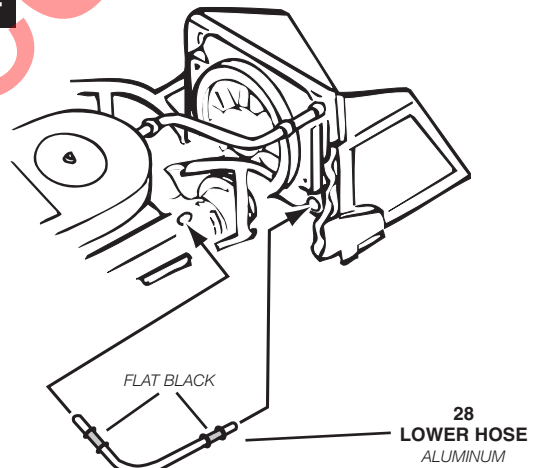

G

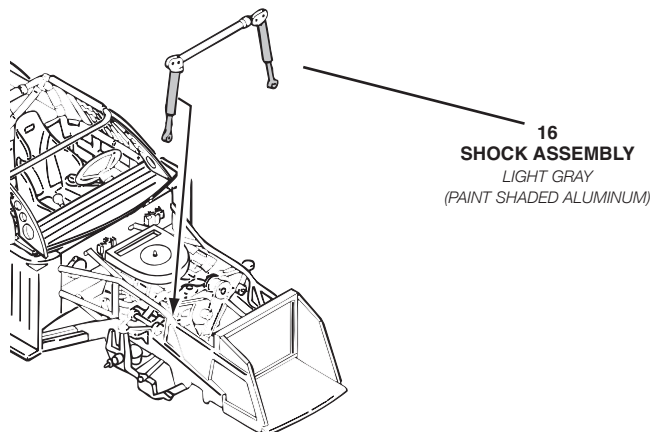

5

FINAL ASSEMBLY

A

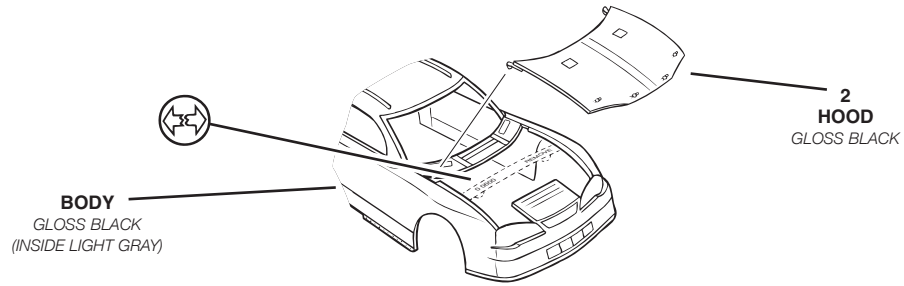

B

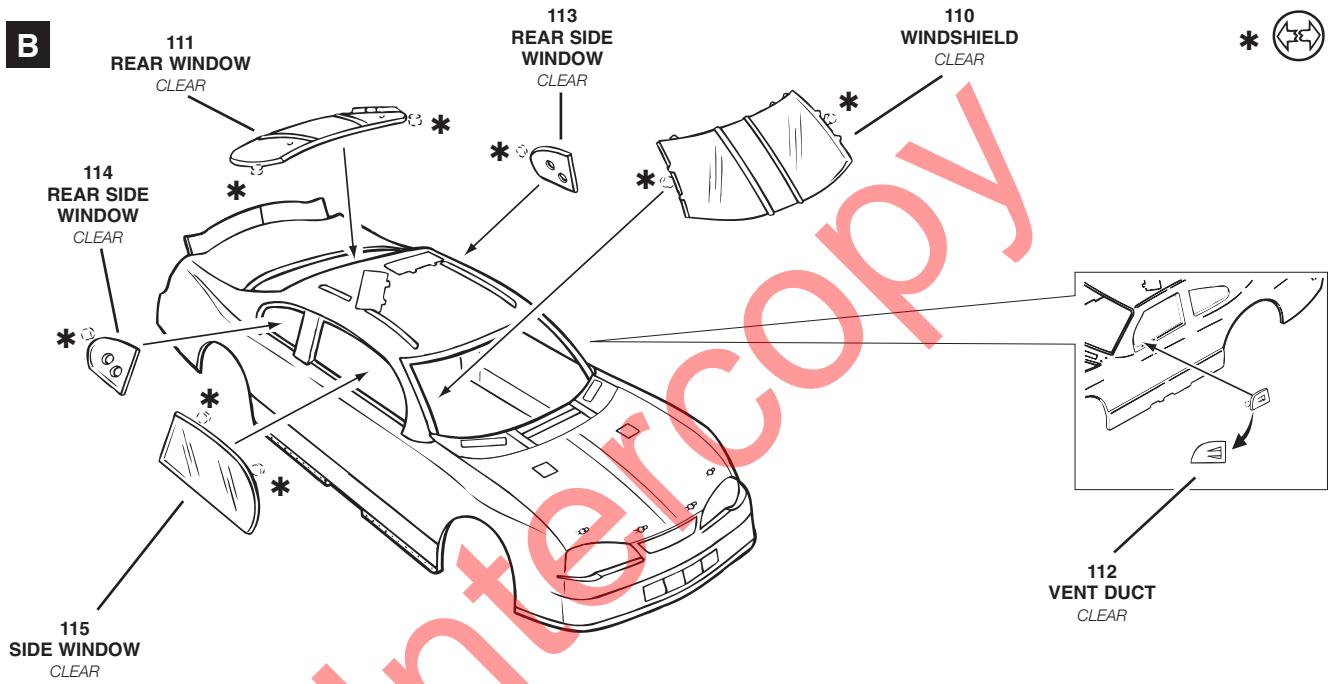

NOTE: PAINT ALL WINDOW TRIM SATIN BLACK

C

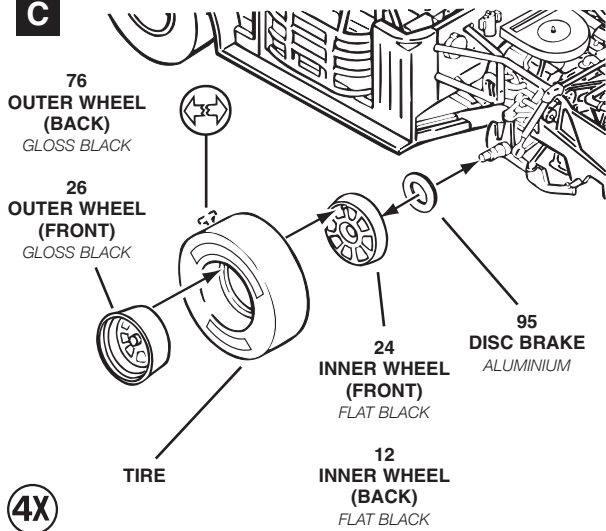

D

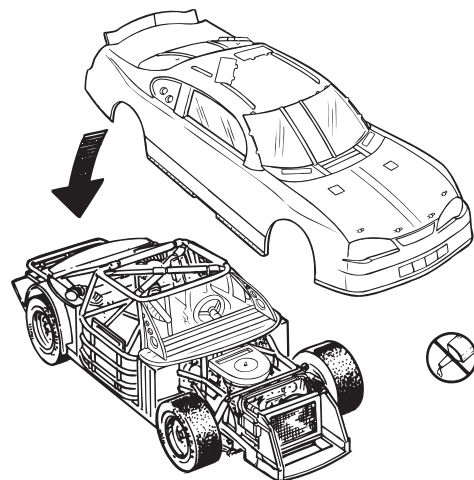

DECAL PLACEMENT

Daytona 500 Version

- BLACK
- SILVER

Apply decals 15, 16, 28, 61, 62, 63 and 64 first.
Note the location of decals 52 before applying decals 42 and 43.

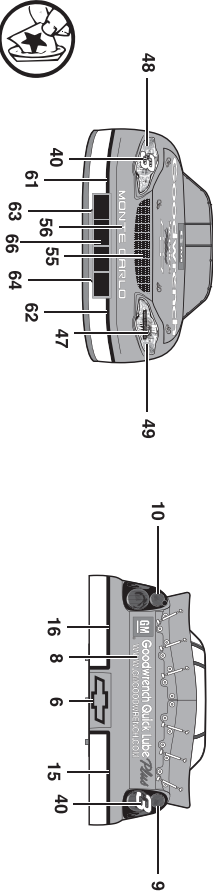
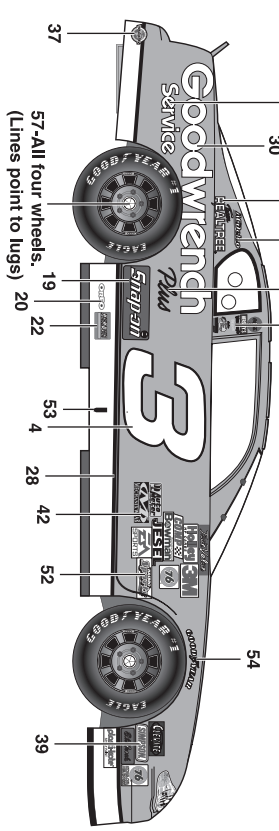
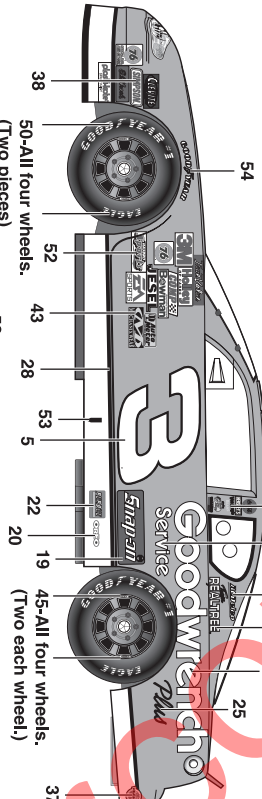
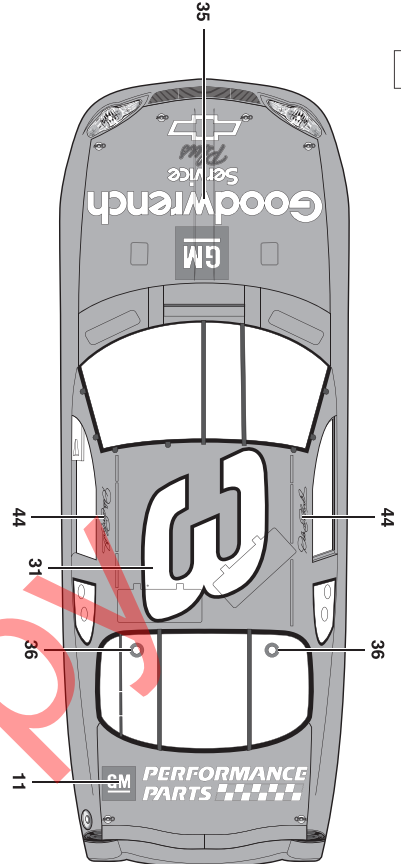

Shootout- Version

Apply decals 17, 18, 29, 59 and 60 first.
Note the location of decals 52 before applying decals 42 and 43.

