



KIT2387

85238700200

40 FORD STANDARD COUPE

Over sixty years after its introduction, the 1940 Ford remains to this day a classic in most everyone's sense of the word. Even those people that do not consider themselves car enthusiasts recognize and generally appreciate the clean design of the Fabulous Forty.

Henry Ford, the founder of the company, is widely remembered as a mechanical genius and the man who developed the modern assembly line, among many other accomplishments. But designing past what was needed to foster efficient assembly was simply not one of Henry's priorities. Through the company's early years, Henry's history making Model T's were largely the same year after year and all painted black just to simplify production.

The job of styling each year's new Fords was left to Henry's son, Edsel. By the 1930's, Edsel's positive influence was evident throughout the lineup.

For the 1939 model year, Edsel and his staff moved the headlamps on the new Ford DeLuxe out to the fenders instead of on either side of the radiator grille. It was one of the first models designed in Ford's new in-house styling department at the company's headquarters in Dearborn and also one of the first that did not have Henry's ham-fisted influence.

1940 carried over the new-for-'39 front end styling to include both the DeLuxe and less expensive Standard models as well as a new body nearly nine inches longer than the previous model. The result was a car that was not

only good looking, but also more spacious for its occupants.

While offering fewer color choices and less chrome trim than the DeLuxe, the Standard models still had that wonderfully flowing design. This was especially true in the case of the coupe, the subject of your Revell kit.

Also commonly called an "opera" coupe at the time, the '40 Standard came equipped with the 60 horsepower version of the famous flathead V8 along with a new-for-'40 steering column mounted shift lever. Available colors included Lyon Blue, Cloud Mist Gray and the ever popular Black with the upper dashboard finished in Briarwood Brown. Wheels were painted black on Standards regardless of body color and the right side tail lamp remained an extra cost option.

Whether you build up your coupe to look like how it would have when it rolled off the showroom floor in 1940 or as a modern street rod with a flame paint job and chrome engine and wheels borrowed from your other Revell kits, we hope you find as much enjoyment as we did developing your new 1940 Ford Standard Coupe.



*** REPEAT SEVERAL TIMES**
* A REPETER PLUSIEURS FOIS



*** OPTIONAL PARTS**
* PIECES EN OPTION



*** DECAL**
* DECAL COMANIE



*** ALTERNATIVE ASSEMBLY**
* ENSEMBLAGE ALTERNATIVE



*** CEMENT TOGETHER**
* A COLLER



*** REMOVE AND THROW AWAY**
* A RETIRER ET JETER



*** DO NOT CEMENT**
* NE PAS COLLER

READ THIS BEFORE YOU BEGIN

- * Study the assembly drawings.
- * Each plastic part is identified by a number.
- * In the assembly drawings, some parts will be marked by a star (★) to indicate chrome plated plastic.
- * For better paint and decal adhesion, wash the plastic parts in a mild detergent solution. Rinse and let air dry.
- * Check the fit of each piece before cementing in place.
- * Use only cement for polystyrene plastic.
- * Scrape plating and paint from areas to be cemented.
- * Allow paint to dry thoroughly before handling parts.
- * Any unused parts may be discarded.

DECAL APPLICATION INSTRUCTIONS

1. Cut desired decal from sheet.
2. Dip decal in water for a few seconds.
3. Place wet decal on paper towel.
4. Wait until decal is movable on paper backing.
5. Place decal in position on model, face up and slide backing away.
6. Press out air bubbles with a soft damp cloth.
7. Milkyness that may appear is for better decal adhesion and will dry clear. Wipe away any excess adhesive.
8. Do not touch decal until fully dry.
9. Allow the decals 48 hours to dry before applying clear coat.

NOTE: Decals are compatible with setting solutions or solvents.

LIRE CE QUI SUIT AVANT DE COMMENCER

- * Etudier les schémas de montage.
- * Chaque pièce en plastique est identifiée par un numéro.
- * Sur les schémas de montage, certaines pièces sont marquées d'une étoile (★) pour indiquer qu'elles sont en plastique chromé.
- * Pour une meilleure prise de la peinture et des autocollants, laver les pièces en plastique avec une solution détergente peu concentrée. Les rincer et les laisser sécher à l'air.
- * Vérifier que chaque pièce s'ajuste bien avant de la coller en place.
- * N'utiliser que de la colle pour polystyrène.
- * Gratter les parties à coller pour enlever le chrome et la peinture.
- * Laisser la peinture bien sécher avant de manipuler les pièces.
- * Toute pièce inutilisée peut être jetée.

DIRECTIVES D'APPLICATION DES AUTOCOLLANTS

1. Découper l'autocollant désiré de la feuille.
2. Tremper l'autocollant dans de l'eau pendant quelques secondes.
3. Placer l'autocollant mouillé sur une serviette en papier.
4. Attendez que l'autocollant puisse être déplacé sur son support en papier.
5. Mettre l'autocollant en position sur le modèle face sur le dessus et faire glisser le support pour l'enlever.
6. Appuyer avec un chiffon doux humide pour éliminer les bulles d'air.
7. La substance laiteuse qui peut apparaître est destinée à améliorer l'adhésion de l'autocollant et devient incolore au séchage. Essuyer pour enlever tout excédent d'adhésif.
8. Ne pas toucher l'autocollant tant qu'il n'est pas bien sec.
9. Laisser l'autocollant sécher pendant 48 heures avant d'appliquer une couche transparente.

REMARQUE: Les autocollants sont compatibles avec les solutions de fixation ou les solvants.

This optional paint guide is provided if you choose to detail paint your model.

Ce guide de peinture vous sera fourni si vous choisissez de peindre votre modèle en détail.

Aluminum	Aluminium
Flat Black	Noir mat
Flat Brown	Vert moteur Ford
Gloss Black	Noir brillant
Gloss Dark Green	Vert brillant
Gunmetal	Ivoire
Ivory	Noir satiné
Semigloss Black	Acier
Steel	Argent
Tan	Havane
Transparent Red	Rouge transparent

If you have any questions or comments, call our hotline at: **(800) 833-3570** or, please write to:

Revell-Monogram Consumer Service Department, 725 Landwehr Road, Northbrook, Illinois 60062

Be sure to include the plan number (85238700200), part number, description, your return address and phone number.

Visit our website: www.revellmonogram.com

1

ENGINE ASSEMBLY

A

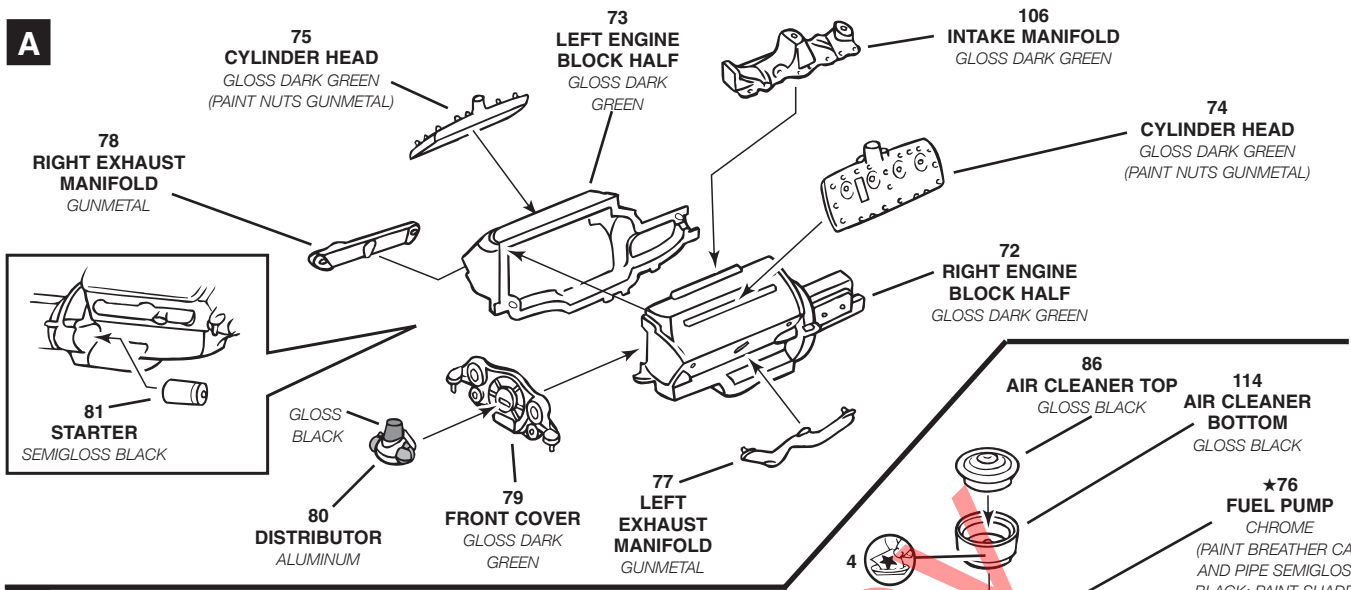

B

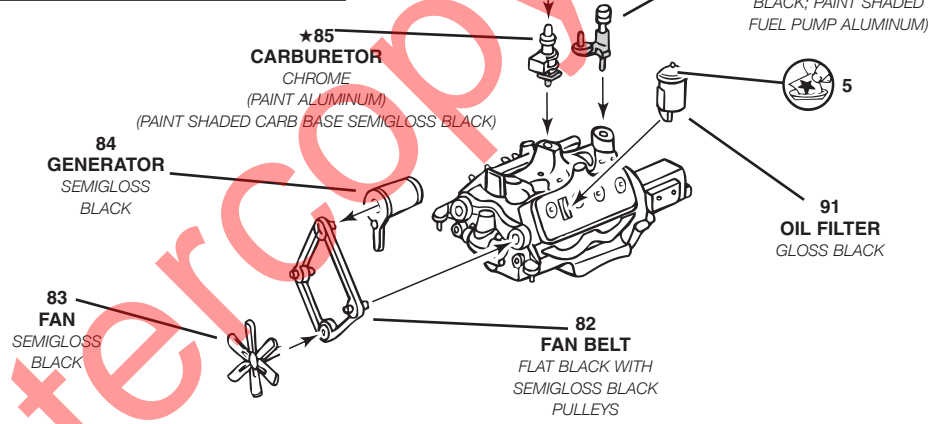

2

FRAME ASSEMBLY

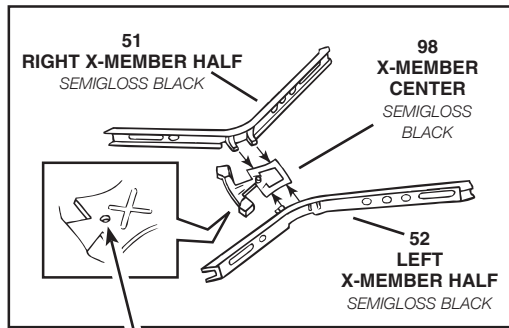

NOTE: OPEN UP SMALL HOLE IN X-MEMBER CENTER

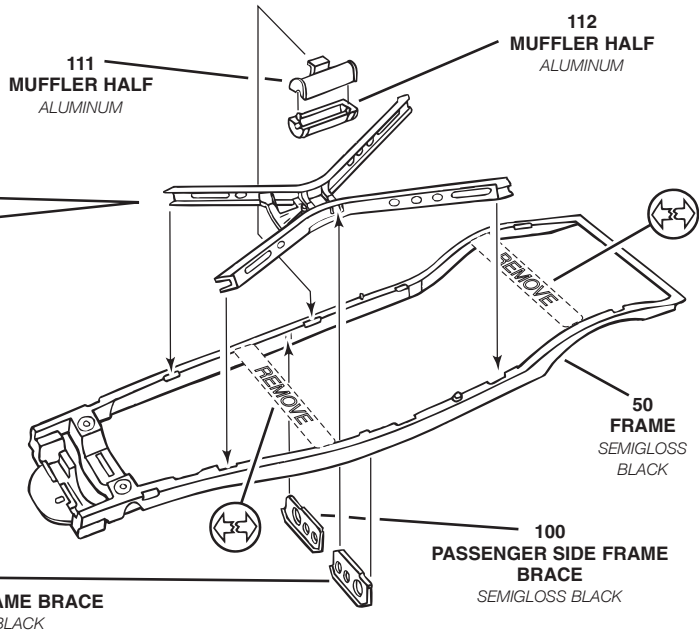

3

FRONT END AND SUSPENSION ASSEMBLY

A

*** INSERT PIPE ENDS INTO HOLES IN MUFFLER BEFORE ATTACHING ENGINE ASSEMBLY**

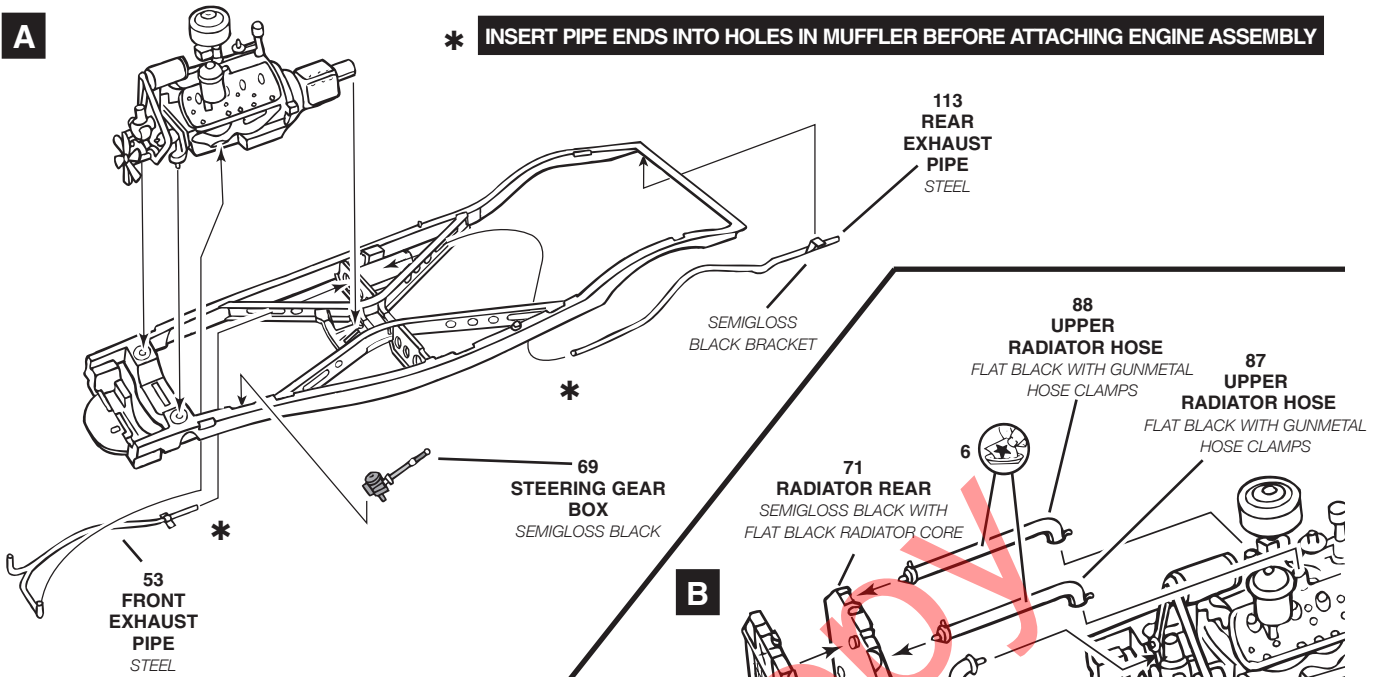

B

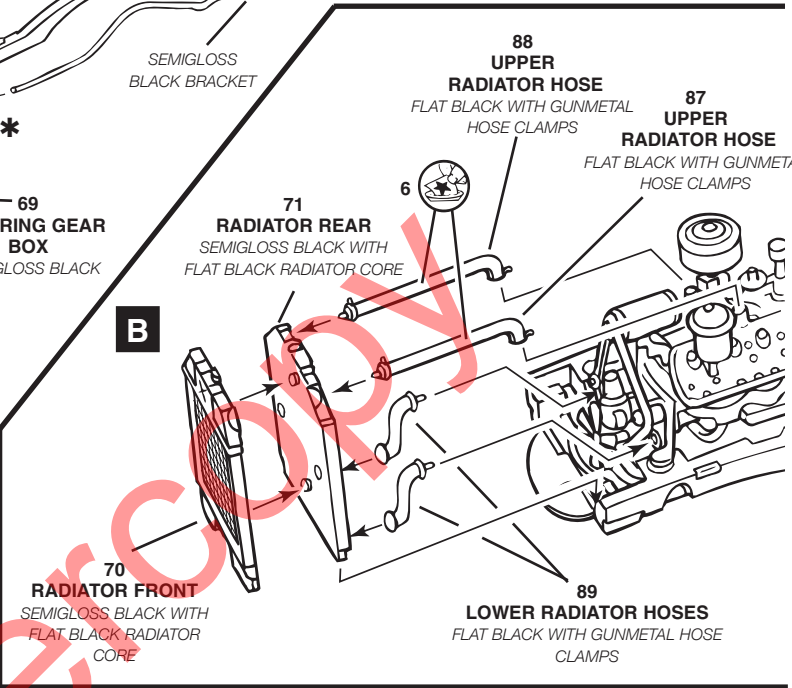

C

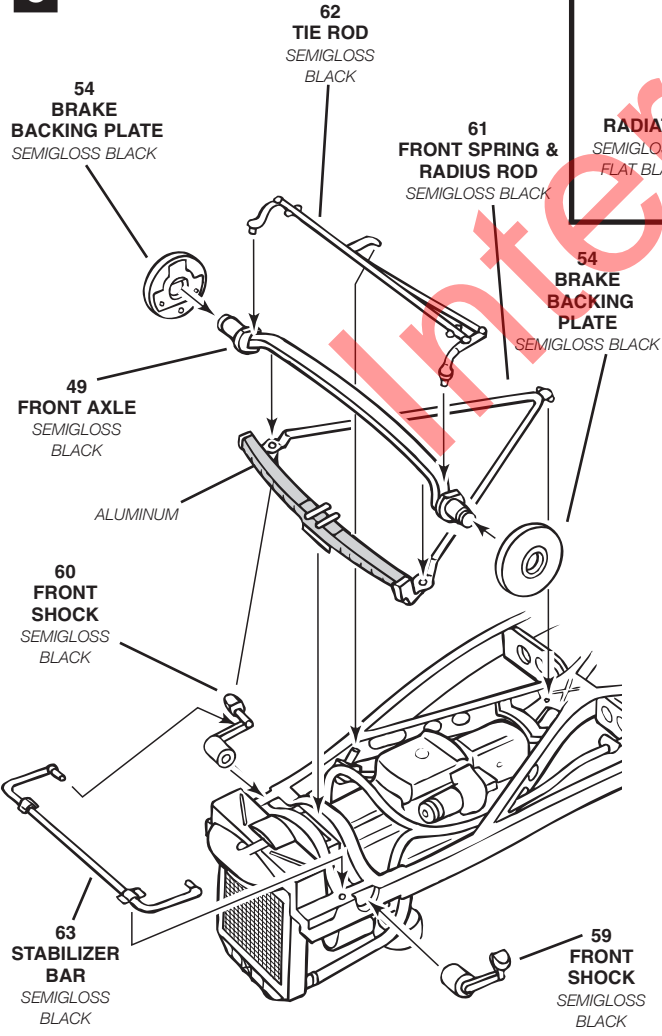

D

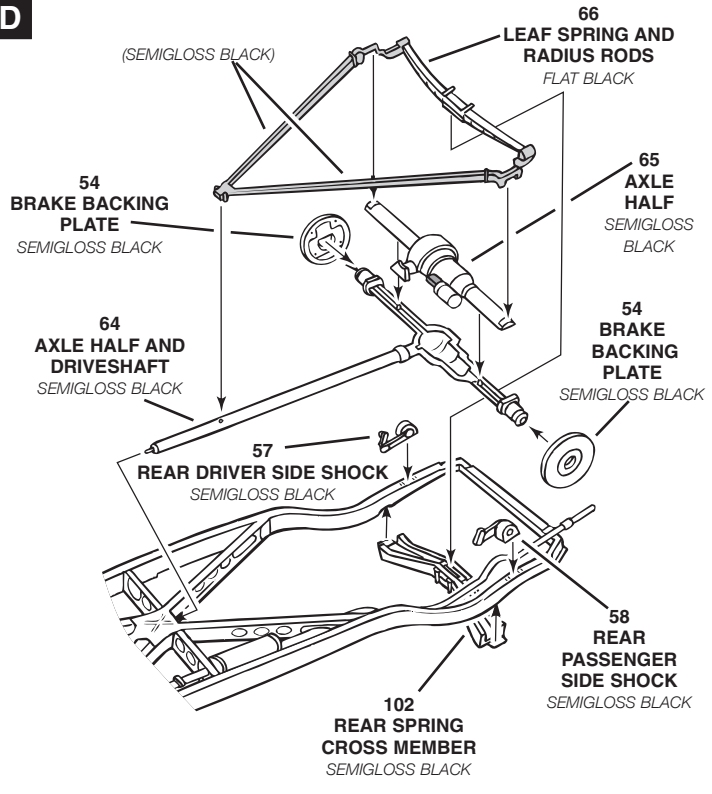

4

WHEEL AND TIRE ASSEMBLY

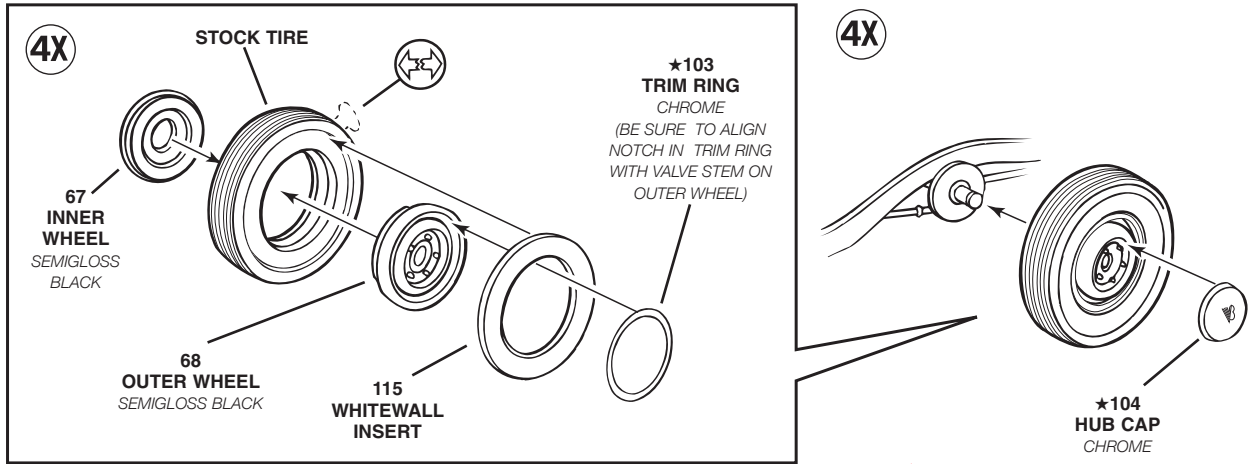

5

WINDOW AND FIREWALL ASSEMBLY

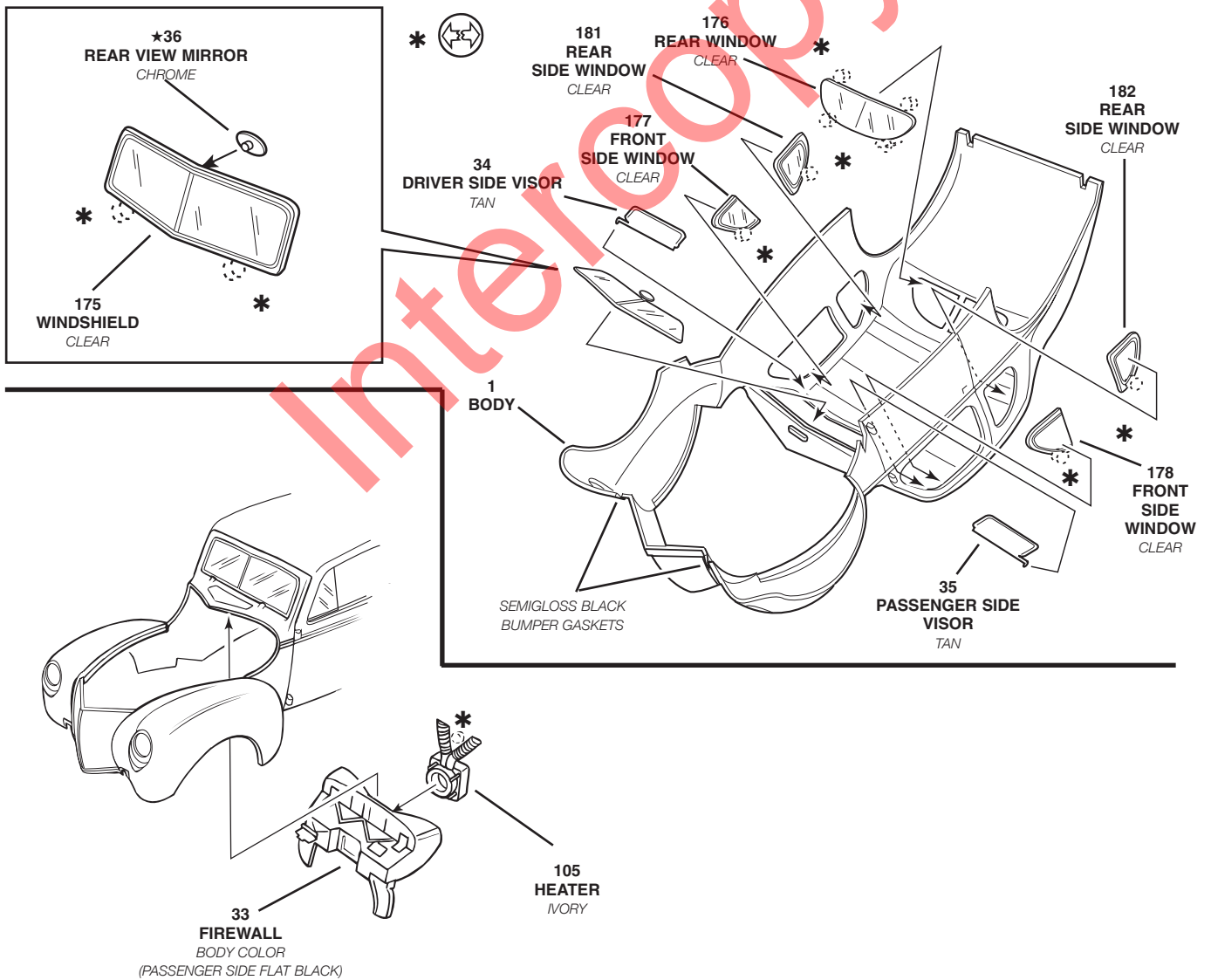

INTERIOR ASSEMBLY

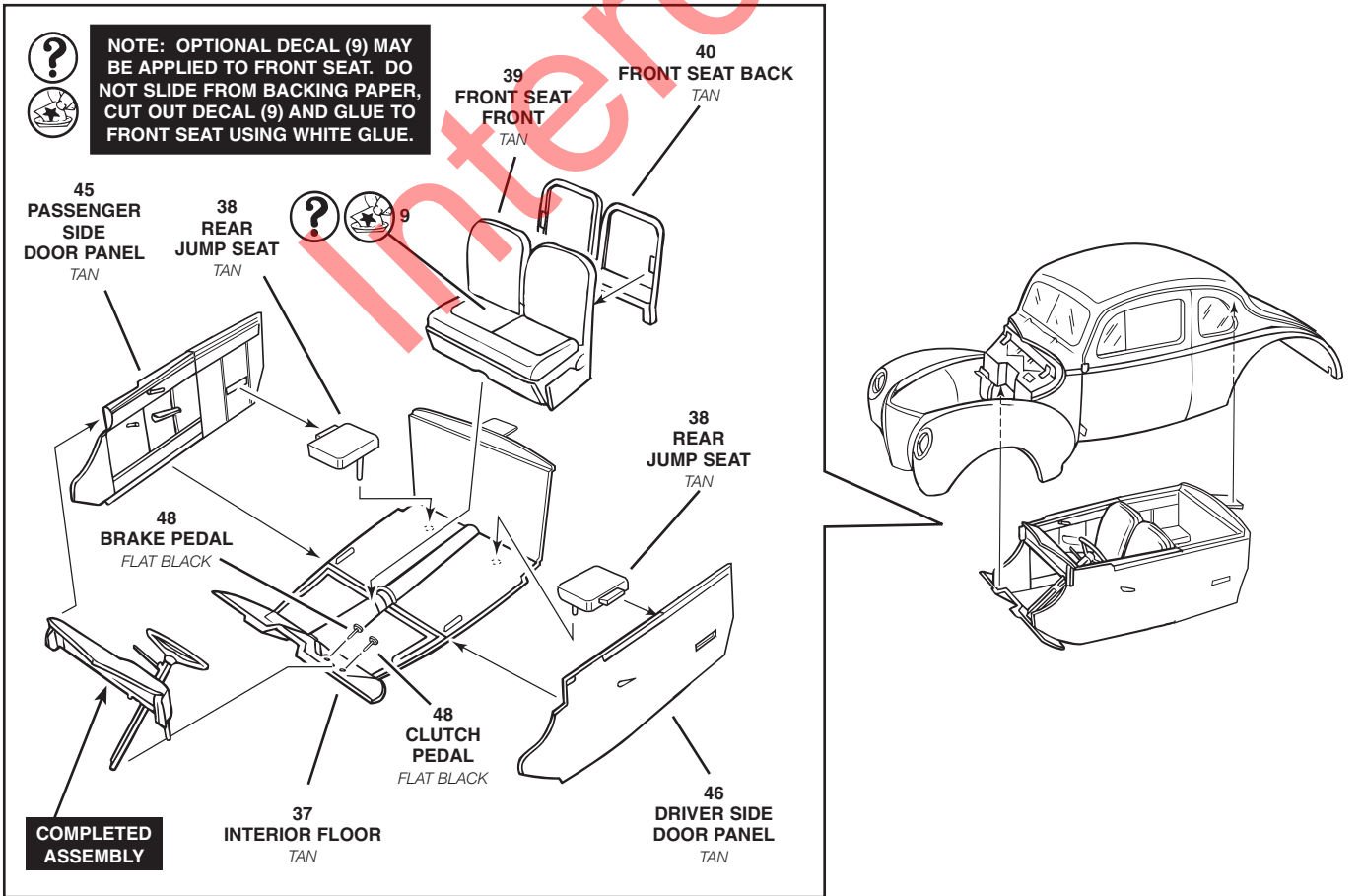
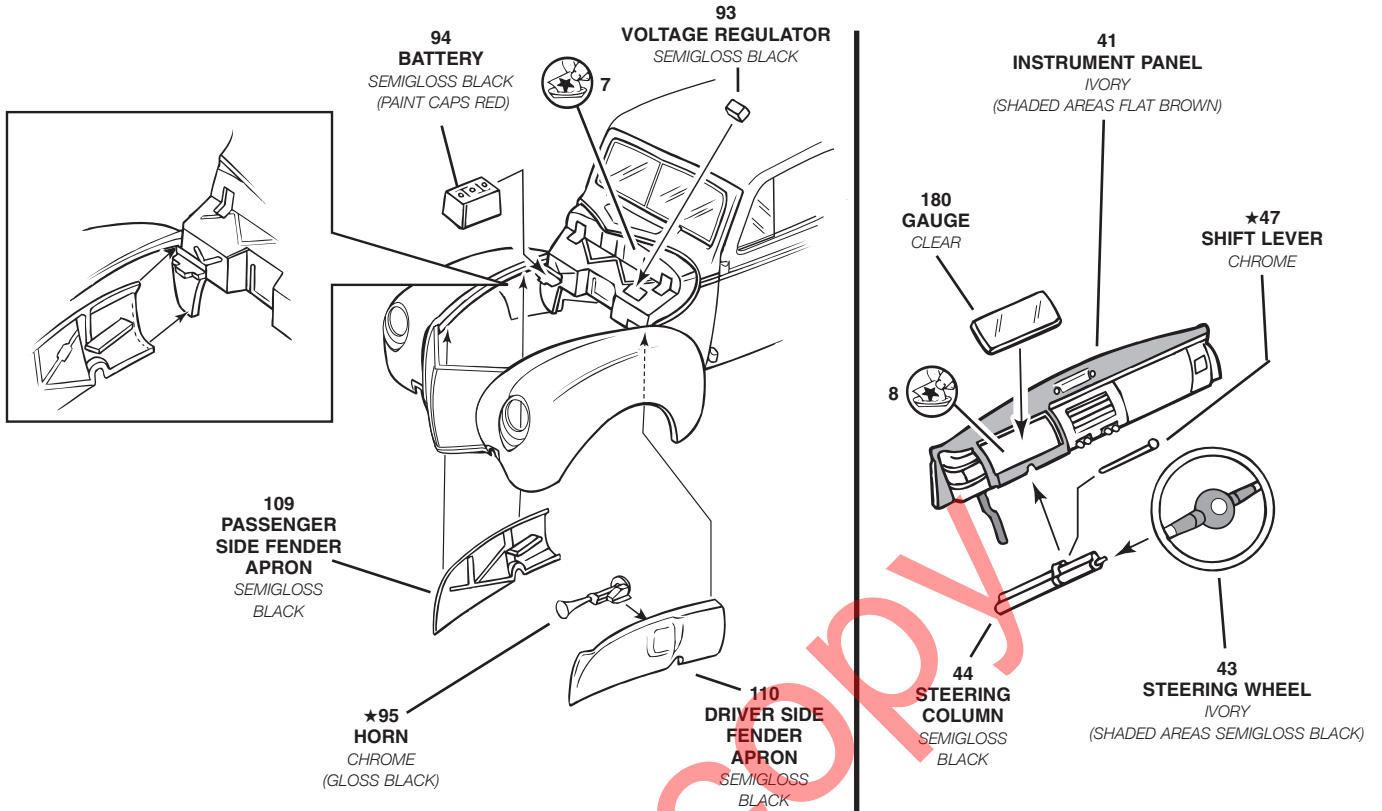

BODY ASSEMBLY

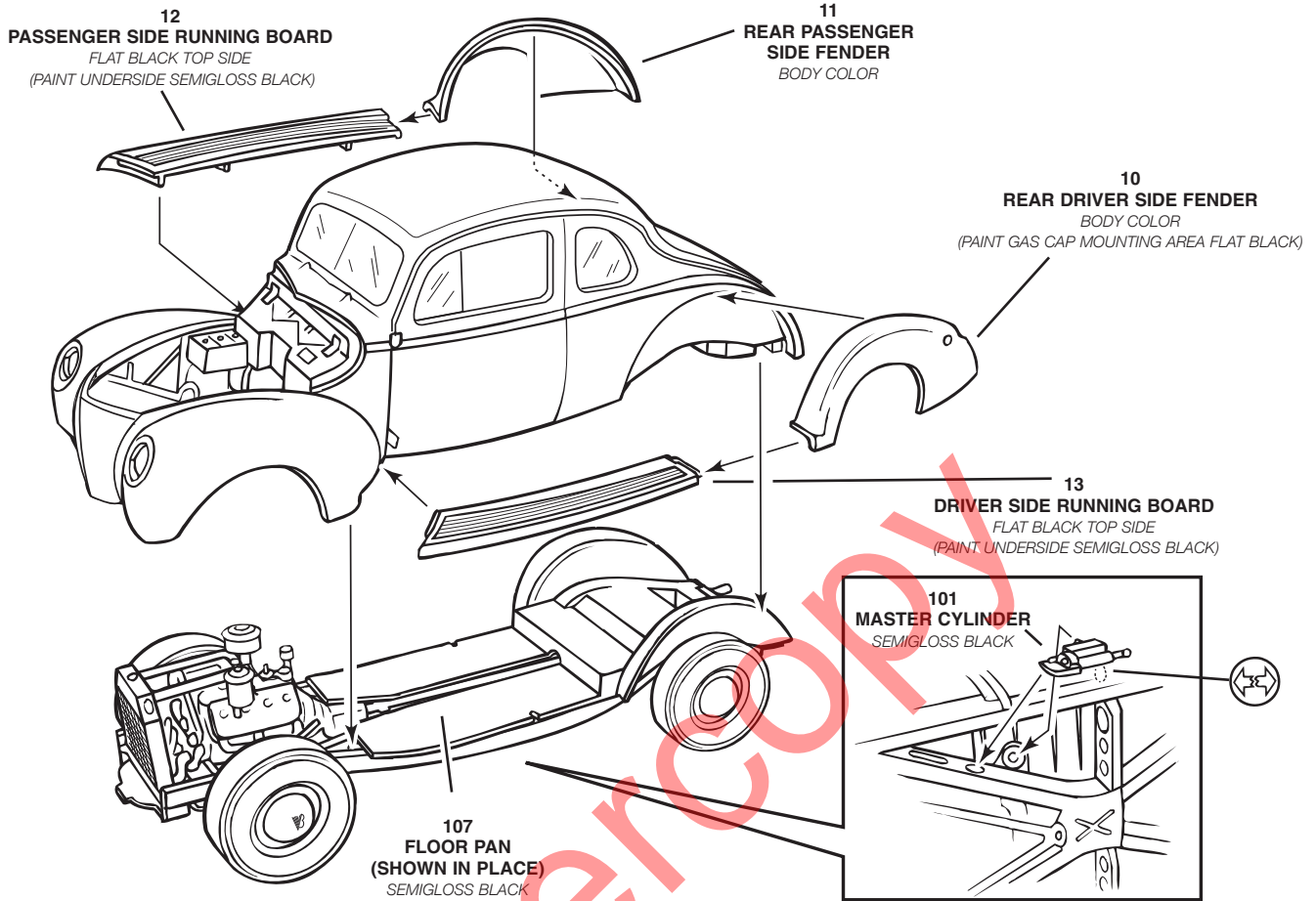

NOTE: YOUR REVELL KIT HAS TWO TAILLIGHTS INCLUDED. THE STANDARD ONLY HAD ONE TAILLIGHT. THE DELUXE VERSION HAD TWO

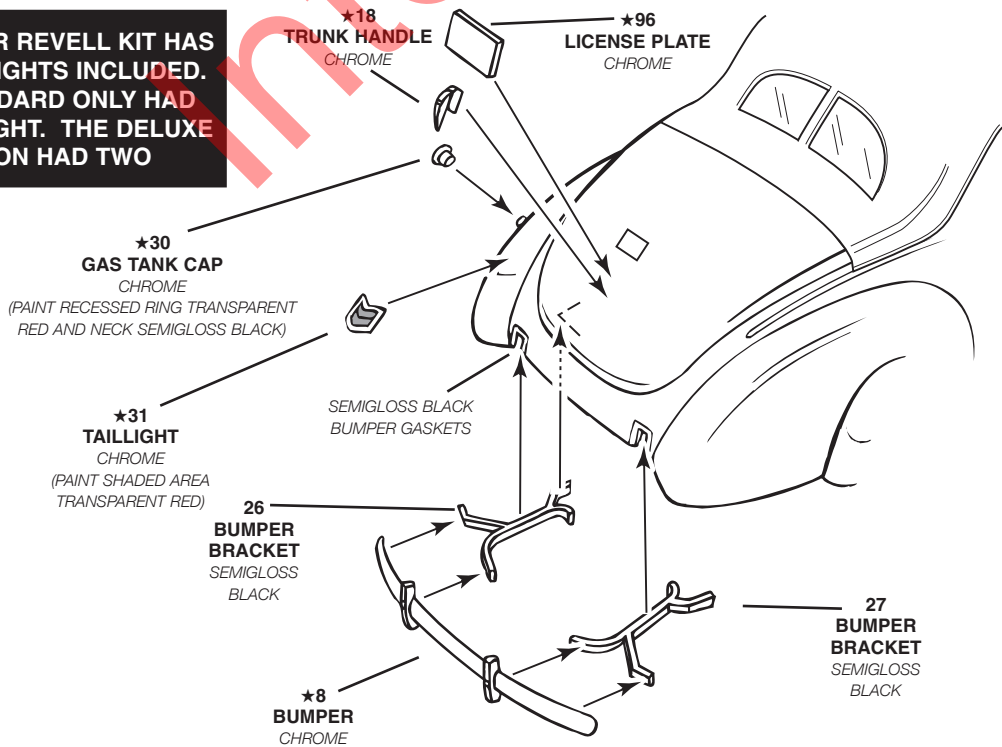

7

BODY ASSEMBLY CONTINUED

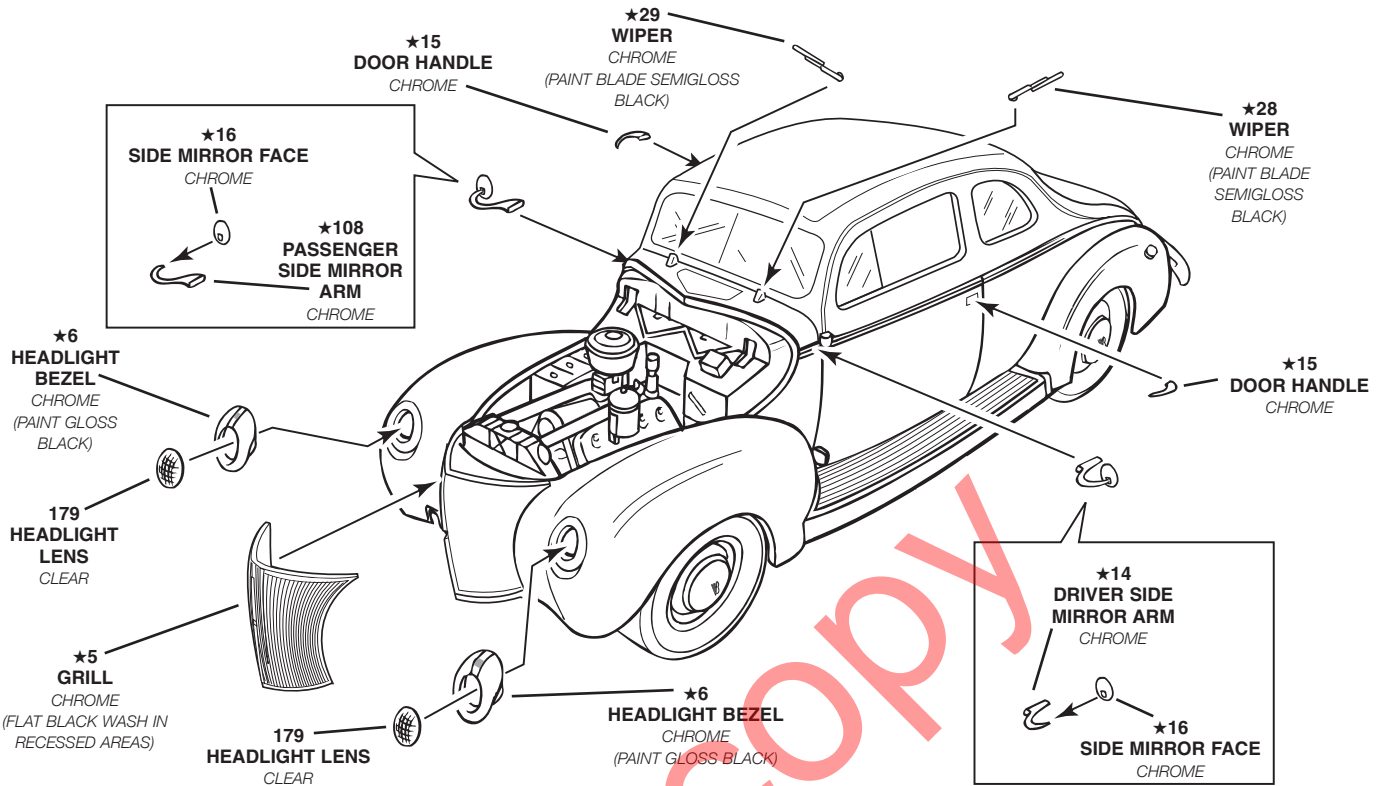

8

HOOD AND BUMPER ASSEMBLY

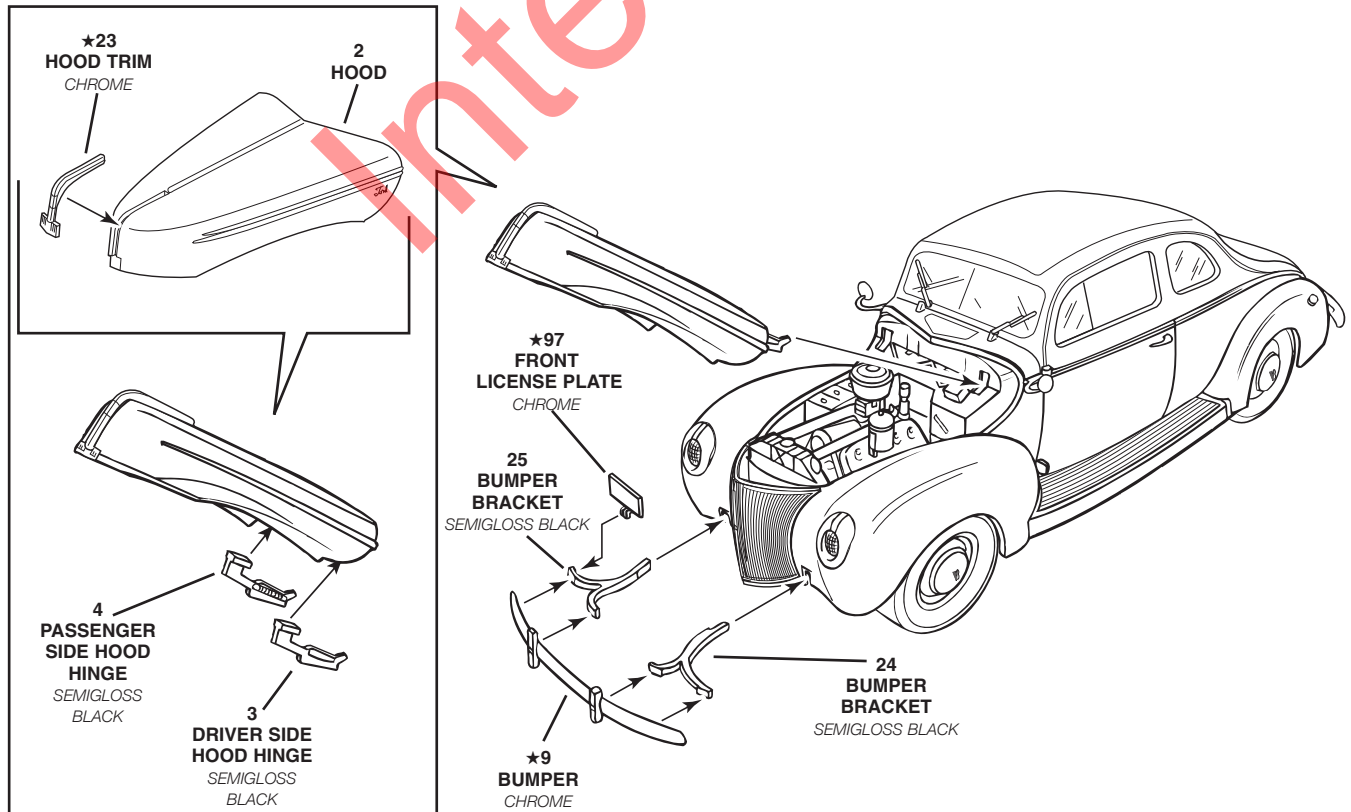

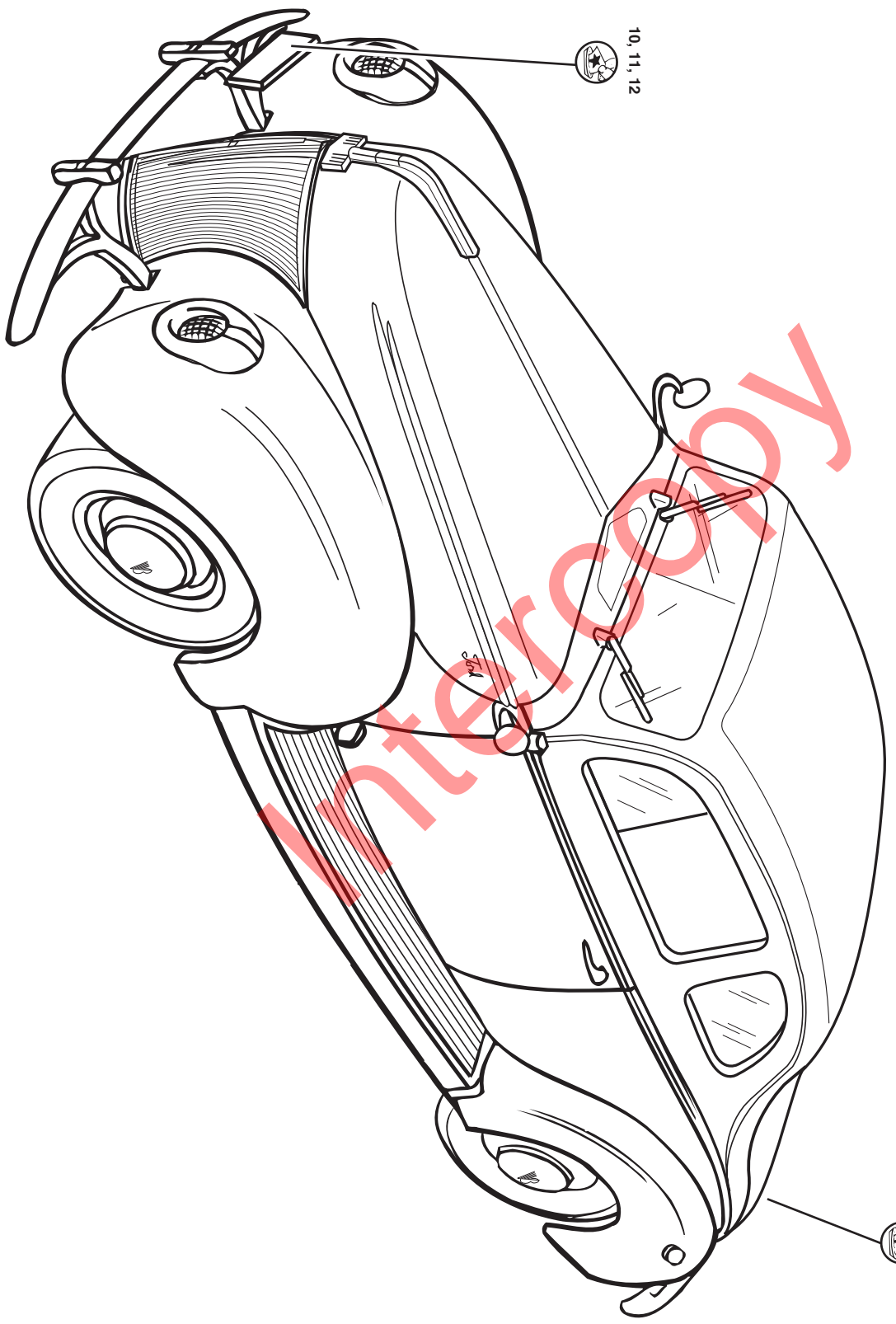

10, 11, 12

10, 11, 12
REAR LICENSE
PLATE