



KIT 2994

85299410200

'70 Boss 429 Mustang 2 'n 1

Boss 429 Mustangs were built in very limited numbers in 1969 and 1970 in order to homologate the radical Boss 429 engine for NASCAR competition. The Boss 429 was a serious engine, with a forged steel crankshaft, four-bolt mains, a 735-cfm Holley four-barrel carb on an aluminum high rise intake manifold, and big-port, staggered valve aluminum heads with crescent-shaped "semi-hemi" combustion chambers. To fit the bulky engine, the Mustang's front suspension had to be moved outward, which widened the front track by two inches and actually improved the handling of the car. The assembly of the Boss 429 Mustangs was handled by Kar Kraft, an outside contractor in Brighton, Michigan. The specialized assembly process and the exotic engine pushed the sticker price up to almost \$5000- a hefty sum in 1970. Today, the Boss 429's are among the rarest and most desirable Mustangs ever produced by Ford.

Your Revell kit may be built as a factory stock 1970 Boss 429 Mustang, or as a customized street machine with dual four barrel carbs on a tunnel ram intake manifold, Shelby style wheels, and custom graphics. The stock version features accurate Magnum 500 wheels, front and rear spoilers, hood scoop, and Boss 429 fender decals.



*** REPEAT SEVERAL TIMES**
* A REPETER PLUSIEURS FOIS



*** OPTIONAL PARTS**
* PIECES EN OPTION



*** DECAL**
* DECAL COMANIE



*** ALTERNATIVE ASSEMBLY**
* ENSEMBLAGE ALTERNATIVE



*** CEMENT TOGETHER**
* A COLLER



*** REMOVE AND THROW AWAY**
* A RETIRER ET JETER



*** DO NOT CEMENT**
* NE PAS COLLER

READ THIS BEFORE YOU BEGIN

- * Study the assembly drawings.
- * Each plastic part is identified by a number.
- * In the assembly drawings, some parts will be marked by a star (★) to indicate chrome plated plastic.
- * For better paint and decal adhesion, wash the plastic parts in a mild detergent solution. Rinse and let air dry.
- * Check the fit of each piece before cementing in place.
- * Use only cement for polystyrene plastic.
- * Scrape plating and paint from areas to be cemented.
- * Allow paint to dry thoroughly before handling parts.
- * Any unused parts may be discarded.

DECAL APPLICATION INSTRUCTIONS

1. Cut desired decal from sheet.
2. Dip decal in water for a few seconds.
3. Place wet decal on paper towel.
4. Wait until decal is movable on paper backing.
5. Place decal in position on model, face up and slide backing away.
6. Press out air bubbles with a soft damp cloth.
7. Milkiness that may appear is for better decal adhesion and will dry clear. Wipe away any excess adhesive.
8. Do not touch decal until fully dry.
9. Allow the decals 48 hours to dry before applying clear coat.

NOTE: Decals are not compatible with setting solutions or solvents.

LIRE CE QUI SUIT AVANT DE COMMENCER

- * Etudier les schémas de montage.
- * Chaque pièce en plastique est identifiée par un numéro.
- * Sur les schémas de montage, certaines pièces sont marquées d'une étoile (★) pour indiquer qu'elles sont en plastique chromé.
- * Pour une meilleure prise de la peinture et des autocollants, laver les pièces en plastique avec une solution détergente peu concentrée. Les rincer et les laisser sécher à l'air.
- * Vérifier que chaque pièce s'ajuste bien avant de la coller en place.
- * N'utiliser que de la colle pour polystyrène.
- * Gratter les parties à coller pour enlever le chrome et la peinture.
- * Laisser la peinture bien sécher avant de manipuler les pièces.
- * Toute pièce inutilisée peut être jetée.

DIRECTIVES D'APPLICATION DES AUTOCOLLANTS

1. Découper l'autocollant désiré de la feuille.
2. Tremper l'autocollant dans de l'eau pendant quelques secondes.
3. Placer l'autocollant mouillé sur une serviette en papier.
4. Attendez que l'autocollant puisse être déplacé sur son support en papier.
5. Mettre l'autocollant en position sur le modèle face sur le dessus et faire glisser le support pour l'enlever.
6. Appuyer avec un chiffon doux humide pour éliminer les bulles d'air.
7. La substance laiteuse qui peut apparaître est destinée à améliorer l'adhésion de l'autocollant et devient incolore au séchage. Essuyer pour enlever tout excédent d'adhésif.
8. Ne pas toucher l'autocollant tant qu'il n'est pas bien sec.
9. Laisser l'autocollant sécher pendant 48 heures avant d'appliquer une couche transparente.

REMARQUE: Les autocollants sont incompatibles avec les solutions de fixation ou les solvants.

This paint guide is provided to complete this kit as shown on the box.

Ce guide de peinture est fourni pour reproduire le modèle réduit qui apparaît sur la boîte.

Aluminum	Aluminum
Chrome Silver	Chrome argent
Flat Black	Noir mat
Flat Light Purple	Pourpre clair mat
Flat White	Blanc mat
Ford Engine Blue	Blue moteur Ford
Gloss Black	Noir lustré
Gloss Light Purple	Pourpre clair lustré
Gloss Metallic Purple	Pourpre lustré métallisé
Grabber Blue	Blue grabber
Silver	Argent
Steel	Acier
Transparent Red	Rouge transparent
Turn Signal Amber	Feu de virage ambre
Wood	Bois

If you have any questions or comments, call our hotline at: **(800) 833-3570**
or, please write to:

Revell-Monogram Consumer Service Department, 8601 Waukegan Road, Morton Grove, Illinois 60053
Be sure to include the plan number (85299410200), part number, description, your return address and phone number.

Visit our website: www.revell-monogram.com

1

ENGINE ASSEMBLY

A

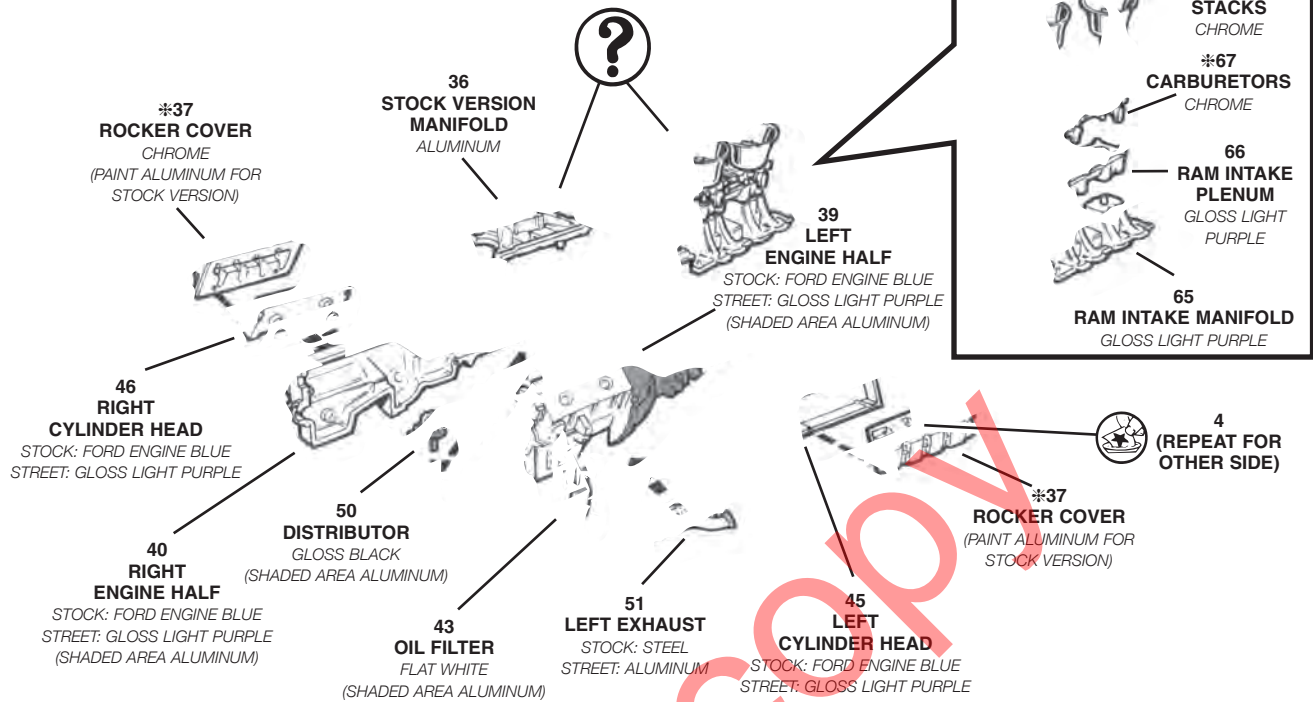

B



STOCK

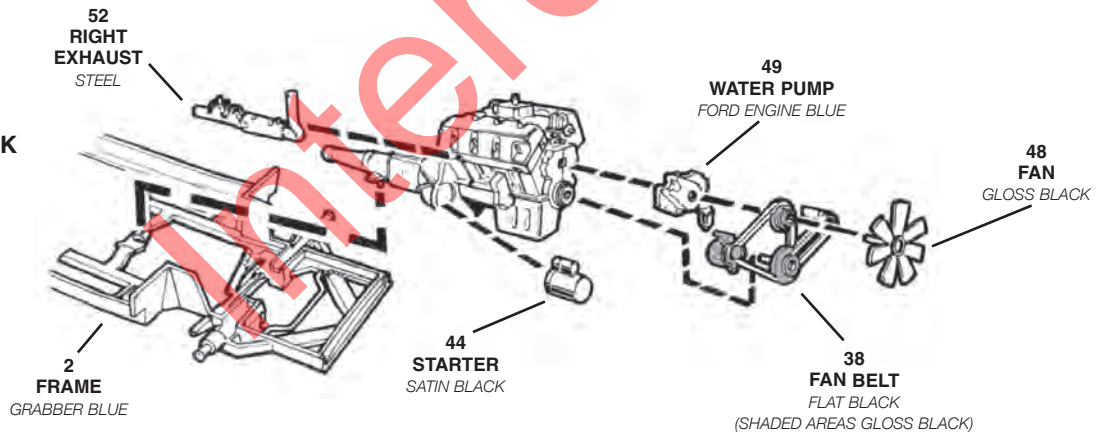

STREET

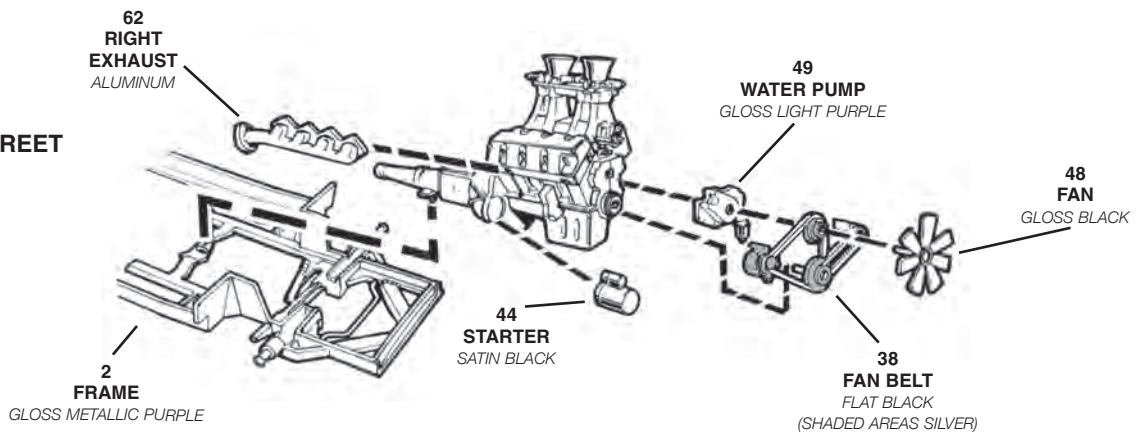

2

INTERIOR ASSEMBLY

A

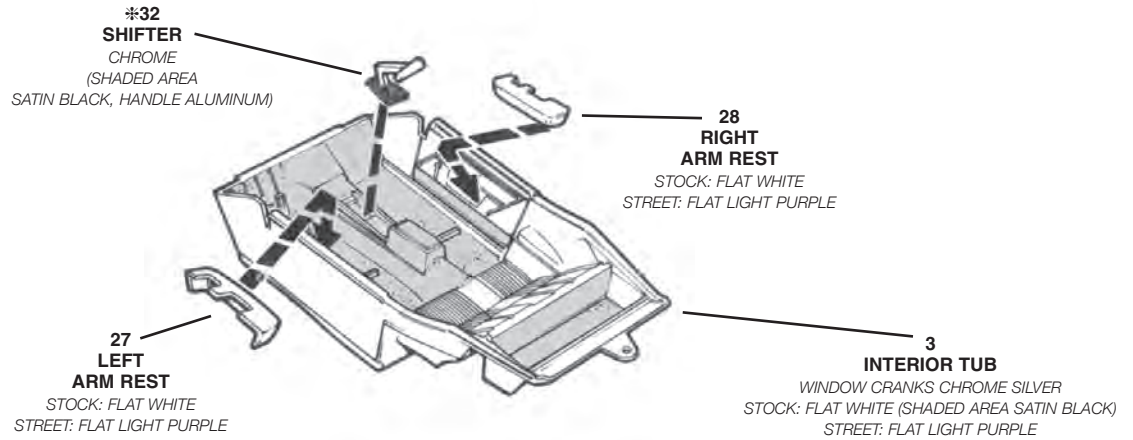

B

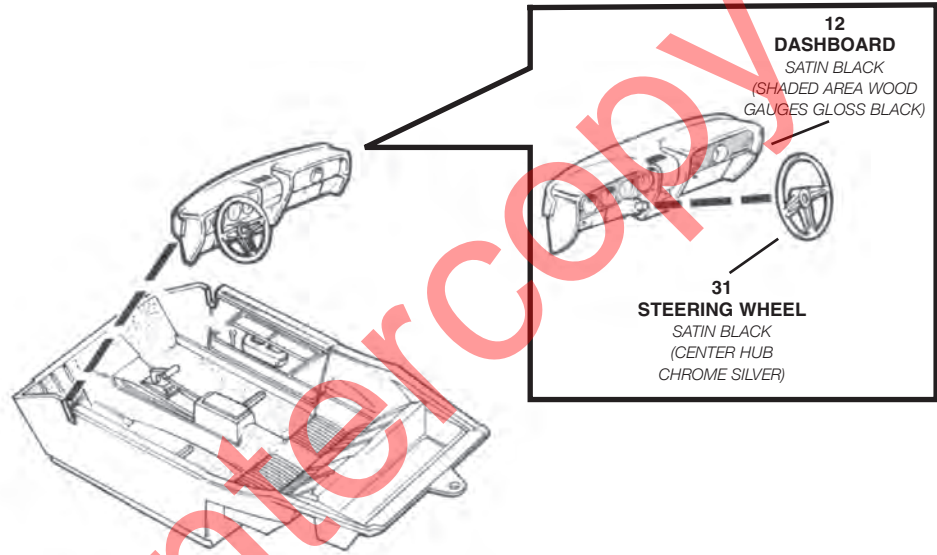

C

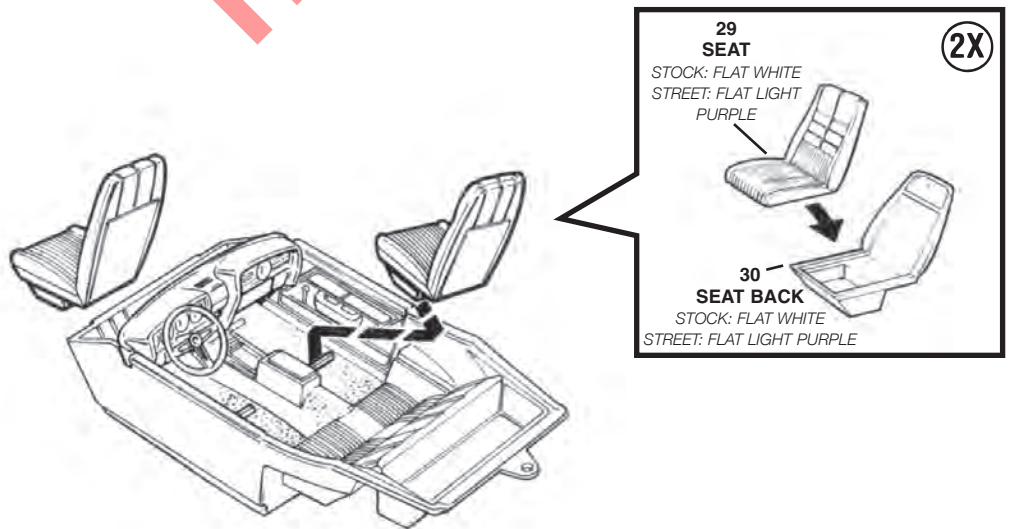

3

BODY ASSEMBLY

A

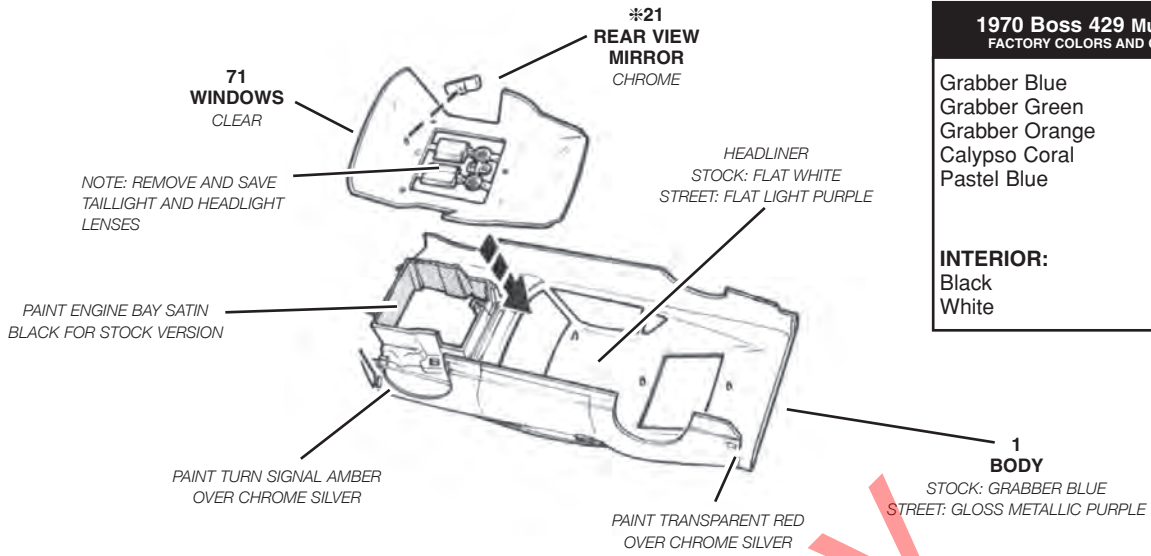

1970 Boss 429 Mustang FACTORY COLORS AND CODES	
Grabber Blue	(J)
Grabber Green	(Z)
Grabber Orange	(U)
Calypso Coral	(1)
Pastel Blue	(N)
INTERIOR:	
Black	(TA)
White	(TW)

B

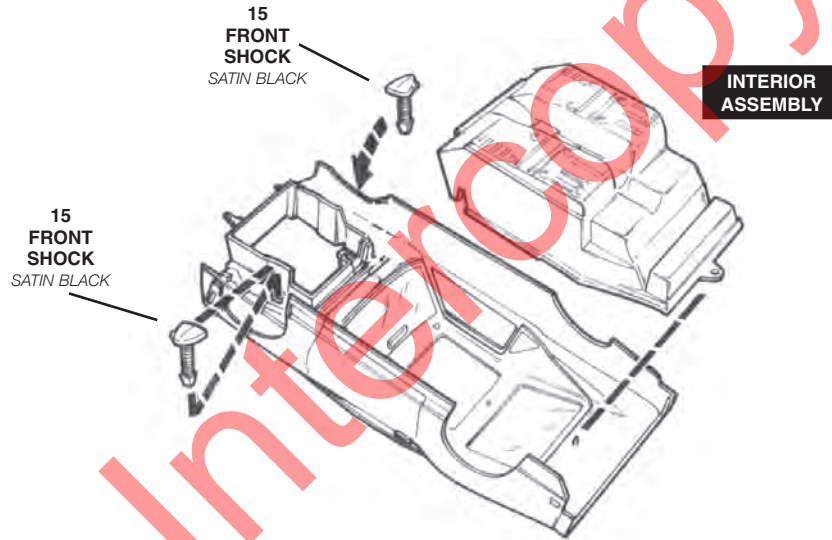

C

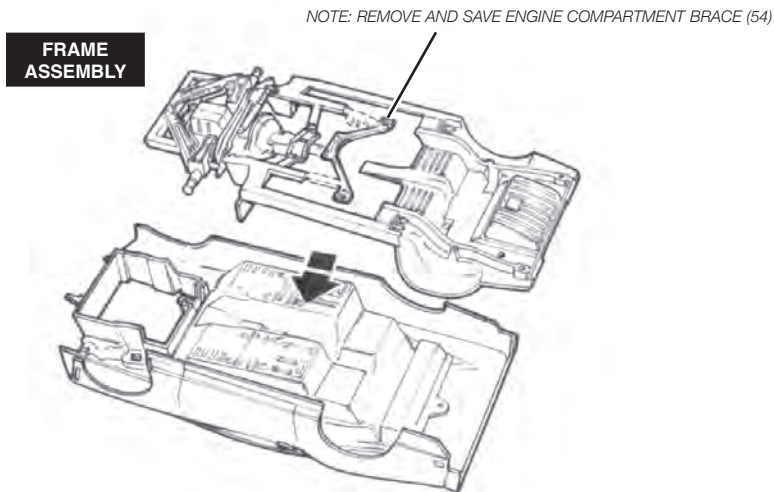

4

CHASSIS ASSEMBLY

A



STOCK

53
EXHAUST SYSTEM
STEEL

14
REAR AXLE
SATIN BLACK

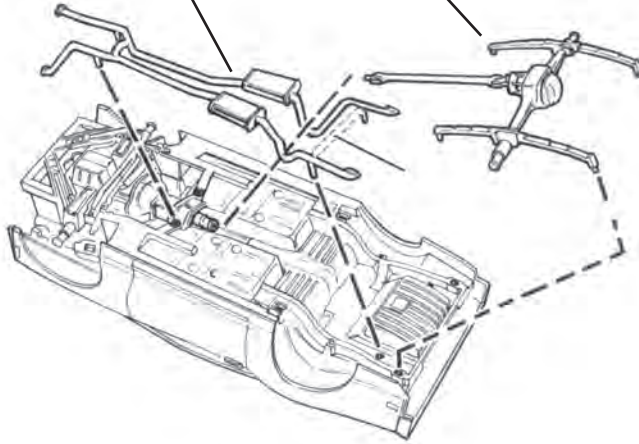

NOTE: ADD AXLE LIFTS
FOR STREET VERSION

STREET

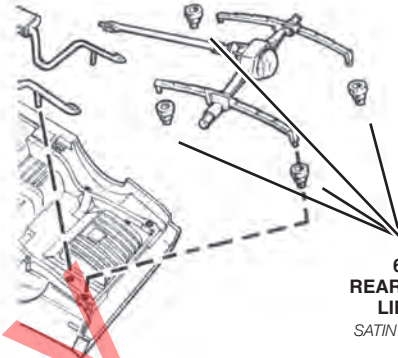

60
REAR AXLE
LIFTS
SATIN BLACK

B



16 (STOCK)
OR
61 (STREET)
REAR
SHOCKS
SATIN BLACK



C

42
RADIATOR TOP
STOCK: SATIN BLACK
STREET: SILVER



25
RADIATOR
FLAT BLACK



6

26
OIL COOLER
FLAT BLACK

54
ENGINE COMPARTMENT
BRACE

STOCK: SATIN BLACK
STREET: SILVER

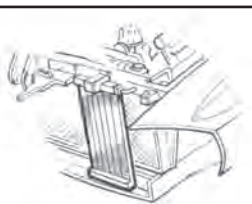

PLACEMENT DETAIL OF
RADIATOR / OIL COOLER
ASSEMBLY

5

FRONT ASSEMBLY

A



STOCK

47 RADIATOR HOSE
FLAT BLACK
(SHADED AREA ALUMINUM)



35 AIR CLEANER
FORD ENGINE BLUE
(SHADED AREA FLAT BLACK)

47 RADIATOR HOSE
FLAT BLACK
(SHADED AREA ALUMINUM)

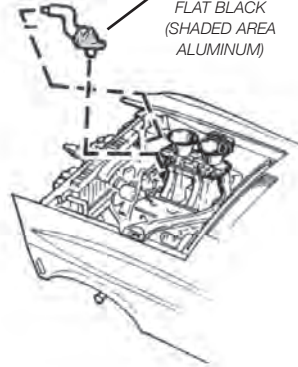

STREET

B

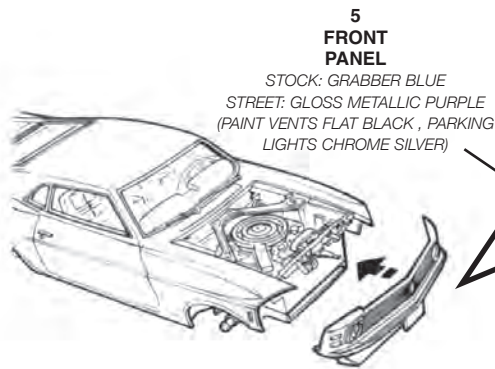

5 FRONT PANEL
STOCK: GRABBER BLUE
STREET: GLOSS METALLIC PURPLE
(PAINT VENTS FLAT BLACK, PARKING LIGHTS CHROME SILVER)

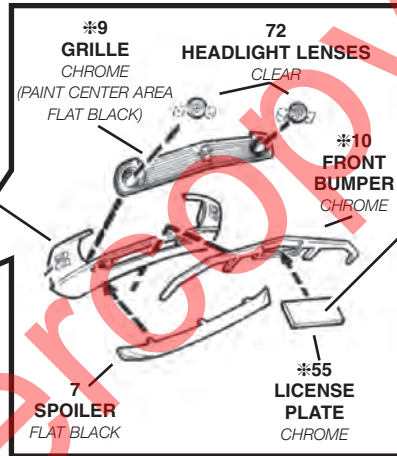

***9 GRILLE**
CHROME
(PAINT CENTER AREA FLAT BLACK)

72 HEADLIGHT LENSES
CLEAR

***10 FRONT BUMPER**
CHROME

7 SPOILER
FLAT BLACK

***55 LICENSE PLATE**
CHROME



1, 2, or 3

PROFILE VIEW OF COMPLETED FRONT END ASSEMBLY



6

REAR ASSEMBLY

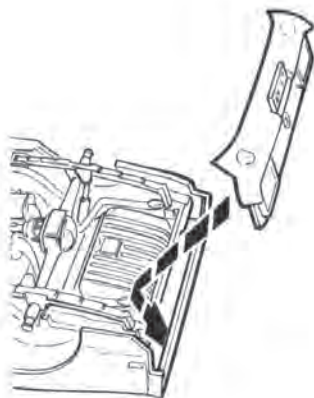

73 TAILLIGHT LENSES
CLEAR
(TRANSPARENT RED OVER CHROME SILVER)

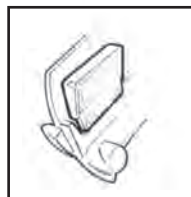

MOUNT TAILLIGHT LENSES ON INSIDE

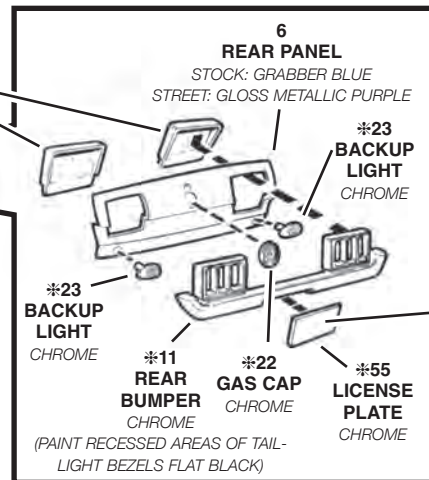

6 REAR PANEL

STOCK: GRABBER BLUE
STREET: GLOSS METALLIC PURPLE

***23 BACKUP LIGHT**
CHROME

***23 BACKUP LIGHT**
CHROME

***11 REAR BUMPER**
CHROME

***22 GAS CAP**
CHROME

***55 LICENSE PLATE**
CHROME

(PAINT RECESSED AREAS OF TAIL-LIGHT BEZELS FLAT BLACK)



1, 2, or 3

A



STOCK

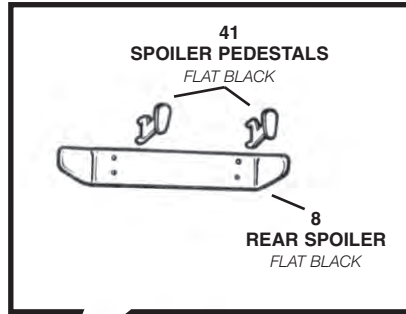

9 and 10
(mount tires lettered side
in when using decals)



*33
**MAGNUM 500
WHEEL**
CHROME
(PAINT RECESSED
AREAS SATIN BLACK)

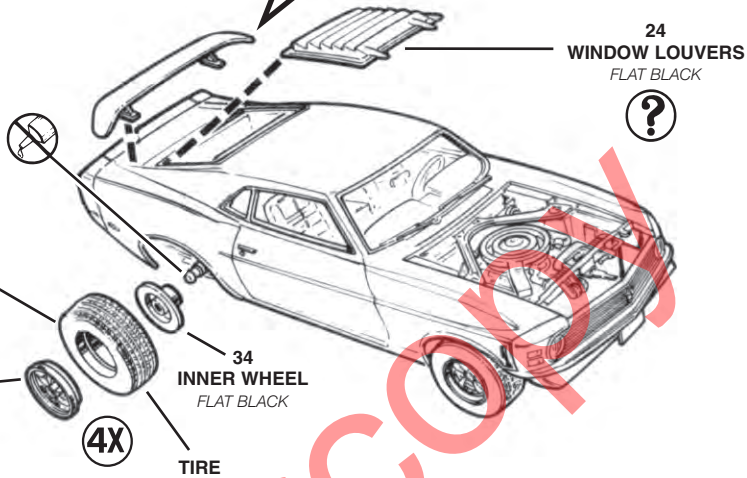

STREET

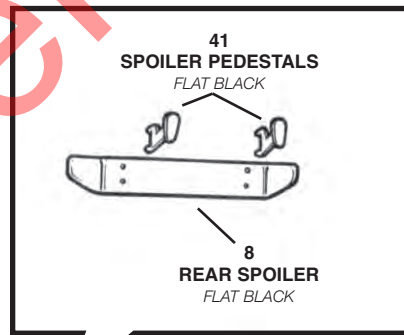

*63
**SHELBY
WHEEL**
CHROME
(PAINT RECESSED
AREAS GLOSS
LIGHT PURPLE)

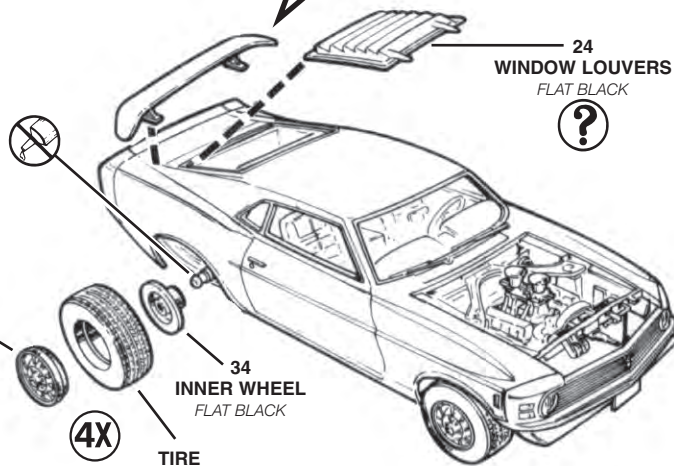

B

! STOCK

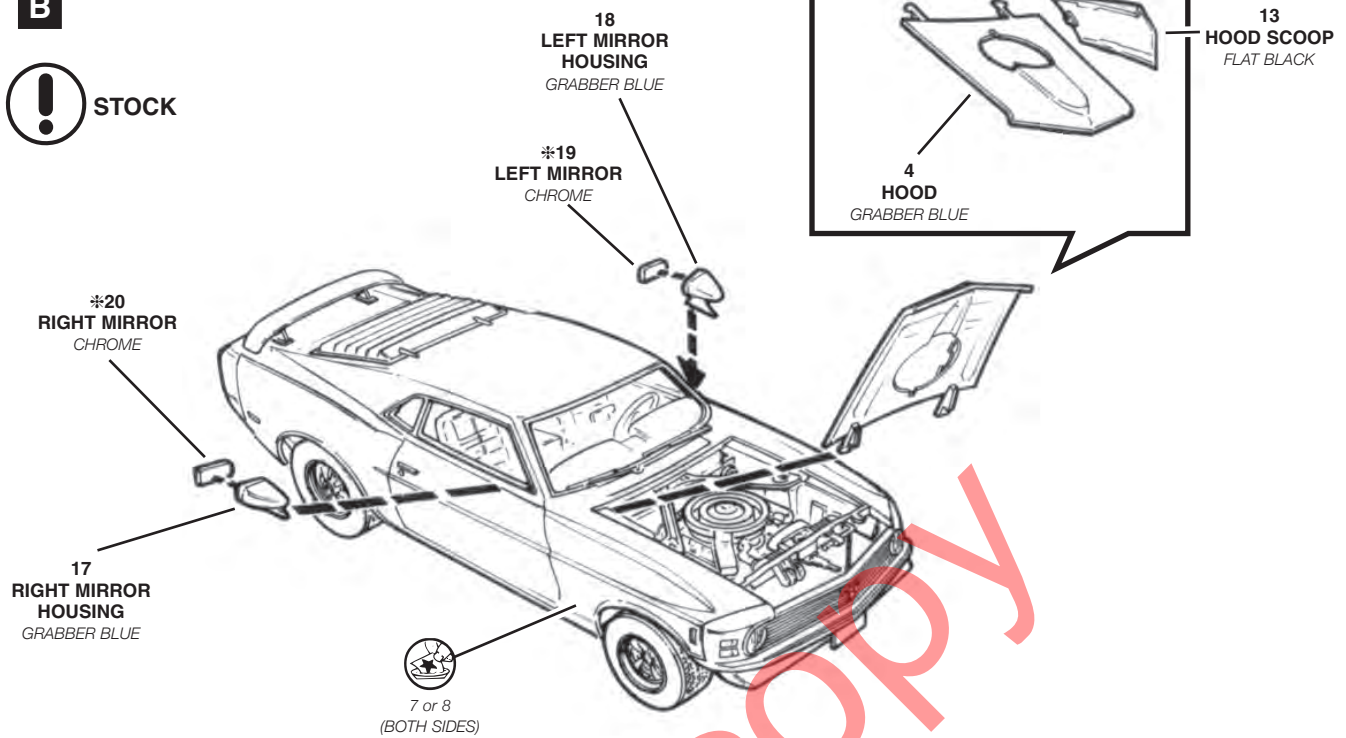

! STREET

