



KIT5243

85524300200

WRIGHT FLYER

"First Powered Flight"

Modern aviation presents us with a wide spectrum of fascinating flying machines. From the adventurous world of "ultralights" to the remarkable flights of the Space Shuttle, mankind has mastered the air in less than a century. At the beginning of the 20th century, these wonders were merely dreams, and this unyielding fascination with flying was born on the wind-swept outer banks of North Carolina in 1903. The Wright Brothers of Ohio were fascinated with the challenge of flying, and their determined efforts culminated in mankind's first powered flight in a heavier-than-air creation on December 17th, 1903. The original Wright Flyer was an unwieldy machine at best. It was powered by a four cylinder engine mounted on the wing alongside the pilot and utilized chain-drive to power two large propellers. A rail-like launching track was used to enable this historic biplane to take to the air in a historical event that is recognized as the birth of modern aviation.

North Carolina's seacoast is a barren and wind-swept vista during the winter months, and you can imagine the scene as Orville Wright eased his body onto the wing of their craft. To the adulation of his brother, Wilbur, and a handful of spectators and assistants, this amazing creation clamored into the air for twelve seconds and flew only 120 feet; less than the wingspan of a modern airliner. This first flight was followed by a second flight that lasted approximately one minute, and the aircraft traveled more than 850 feet. Today, this historic flying machine is one of the most treasured displays in the National Air and Space Museum located in Washington D.C. Suspended above the main entrance the Wright Flyer shares its fame with such memorable creations as the "Spirit of St. Louis" and an Apollo spacecraft. Surely, the achievements of this aviation relic may seem small, but this is the aircraft that first enabled man to fly with the birds and fulfill a centuries-old dream.

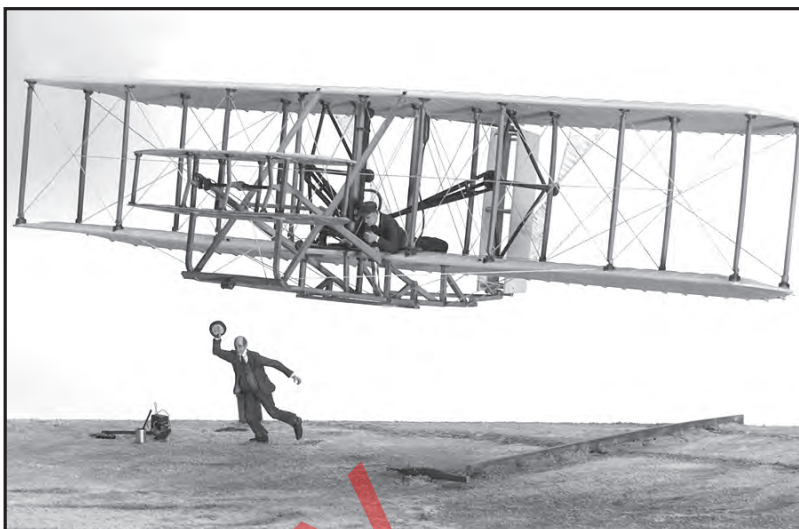

* REPEAT SEVERAL TIMES

* A REPETER PLUSIEURS FOIS



* OPTIONAL PARTS

* PIECES EN OPTION



* DECAL

* DECAL COMANIE



* ALTERNATIVE ASSEMBLY

* ENSEMBLAGE ALTERNATIVE



* CEMENT TOGETHER

* A COLLER



* REMOVE AND THROW AWAY

* A RETIRER ET JETER



* DO NOT CEMENT

* NE PAS COLLER

READ THIS BEFORE YOU BEGIN

- * Study the assembly drawings.
- * Each plastic part is identified by a number.
- * For better paint adhesion, wash the plastic parts in a mild detergent solution. Rinse and let air dry.
- * Check the fit of each piece before cementing in place.
- * Use only cement for polystyrene plastic.
- * Scrape and paint from areas to be cemented.
- * Allow paint to dry thoroughly before handling parts.
- * Any unused parts may be discarded.

LIRE CE QUI SUIT AVANT DE COMMENCER

- * Etudier les schémas de montage.
- * Chaque pièce en plastique est identifiée par un numéro.
- * Pour une meilleure prise de la peinture, laver les pièces en plastique avec une solution détergente peu concentrée. Les rincer et les laisser sécher à l'air.
- * Vérifier que chaque pièce s'ajuste bien avant de la coller en place.
- * N'utiliser que de la colle pour polystyrène.
- * Gratter les parties à coller pour enlever le chrome et la peinture.
- * Laisser la peinture bien sécher avant de manipuler les pièces.
- * Toute pièce inutilisée peut être jetée.

This optional paint guide is provided if you choose to detail paint your model.

Ce guide de peinture vous sera fourni si vous choisissez de peindre votre modèle en détail.

White	Blanc
Flesh	Chair
Flat Black	Noir mat
Red	Rouge
Silver	Argent
Steel	Acier

If you have any questions or comments, call our hotline at: **(800) 833-3570**
or, please write to:

Revell-Monogram Consumer Service Department, 725 Landwehr Road, Northbrook, Illinois 60062

Be sure to include the plan number (85524300200), part number, description, your return address and phone number.

Visit our website: www.revellmonogram.com

1

ENGINE AND SUPPORT ASSEMBLY

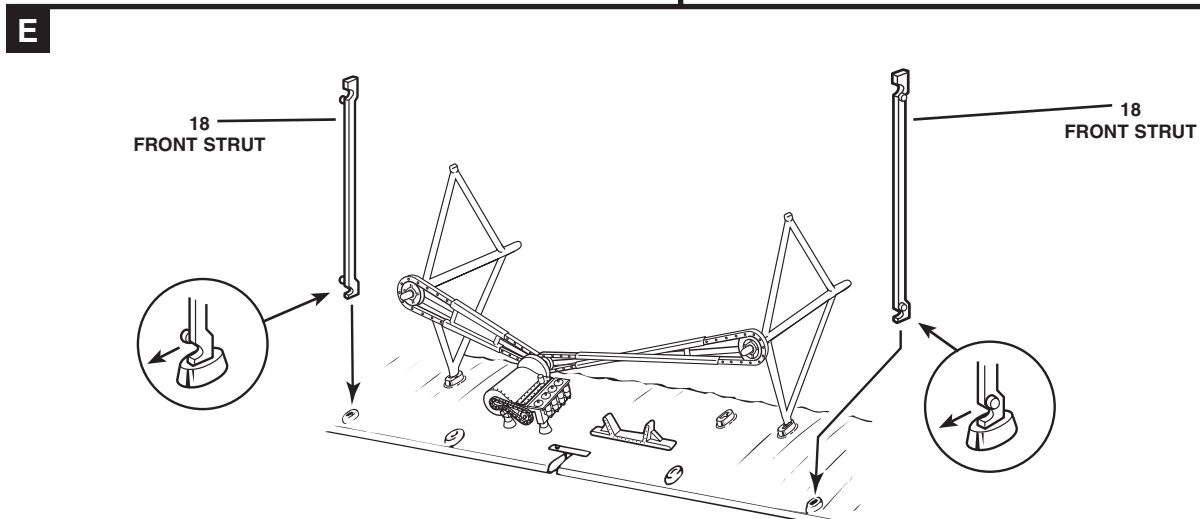
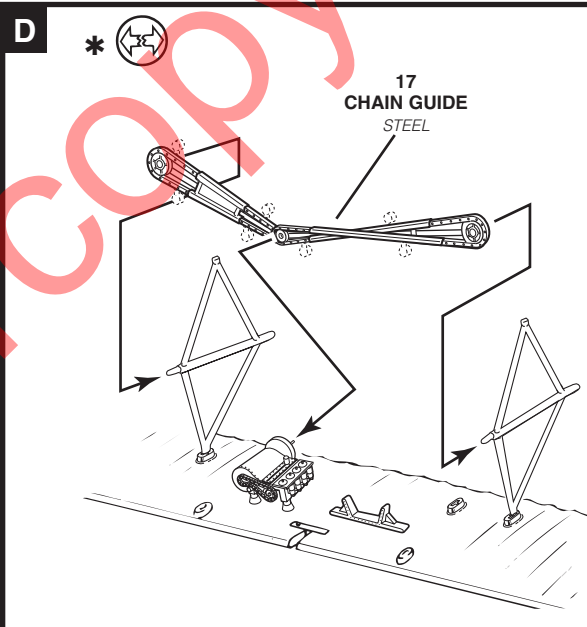
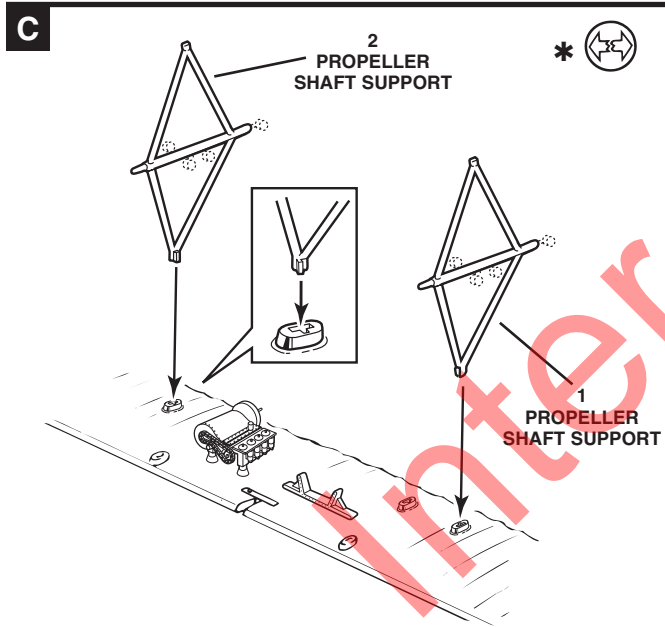
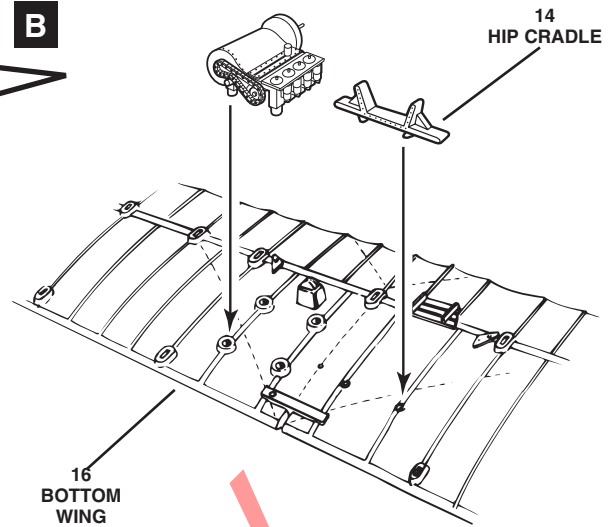
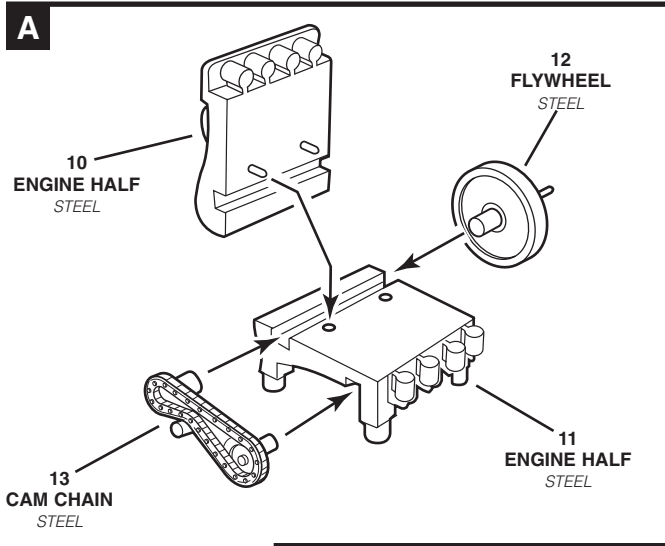

2 WING AND REAR RUDDER ASSEMBLY

A

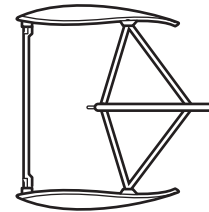
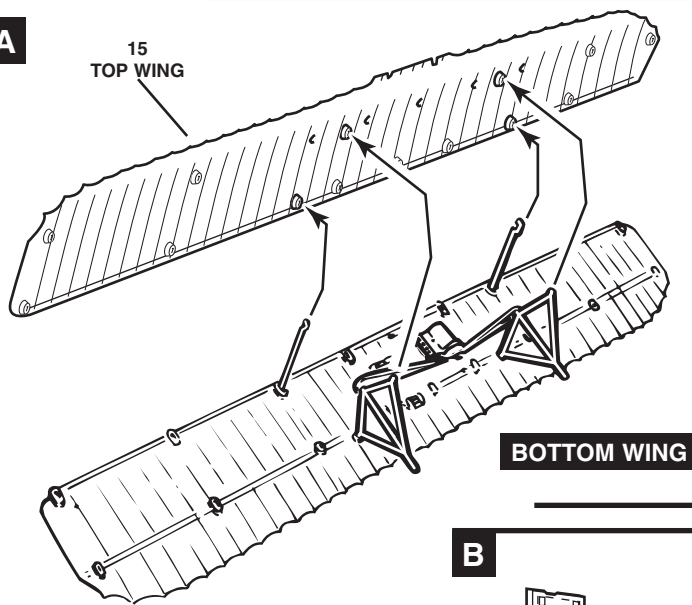

B

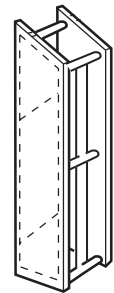
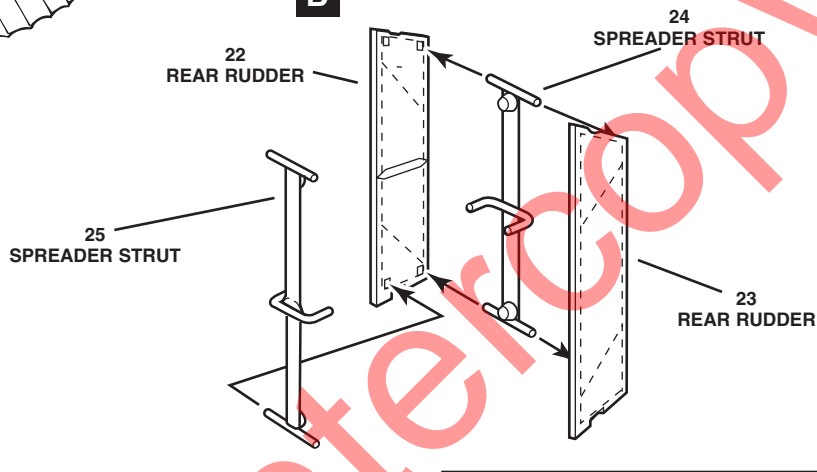

3

FRONT RUDDER ASSEMBLY

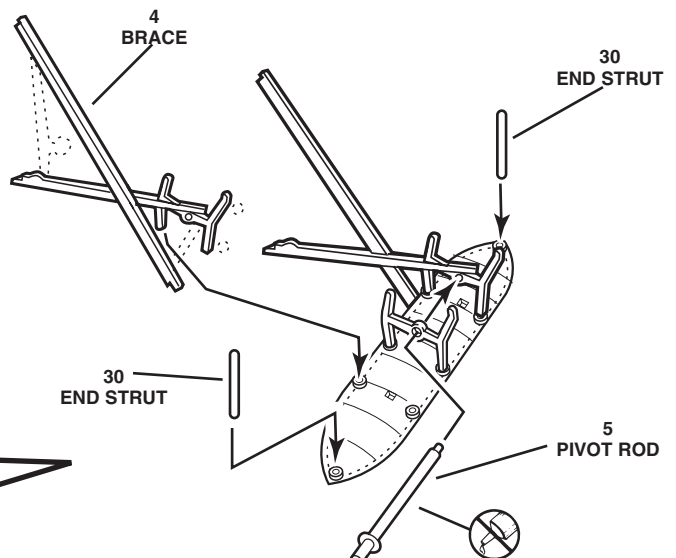
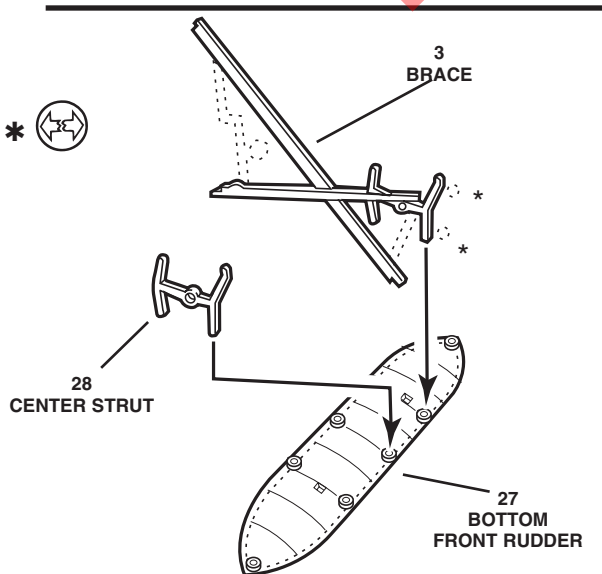

3

FRONT RUDDER ASSEMBLY CONTINUED

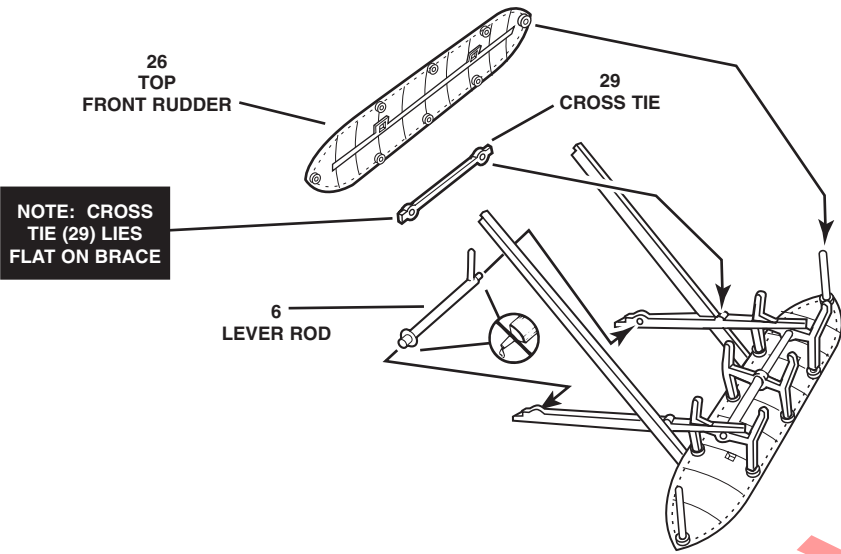

4

STRUTS ASSEMBLY

A

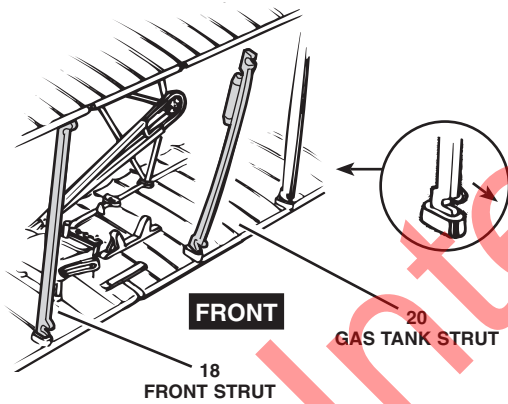

B

PUSH ON CAREFULLY

19
REAR STRUT

REAR

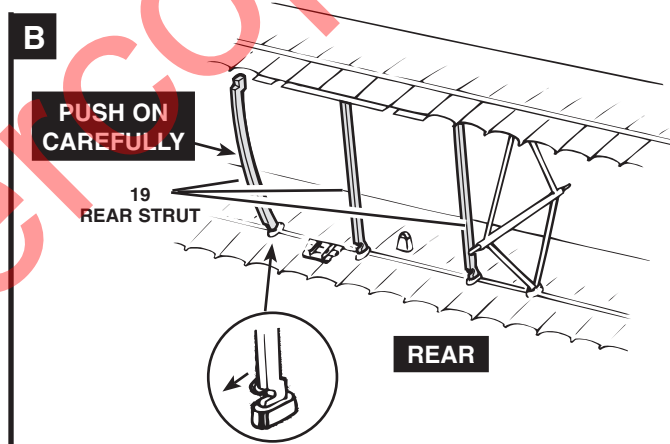

C

REAR

FRONT

31
RADIATOR STRUT

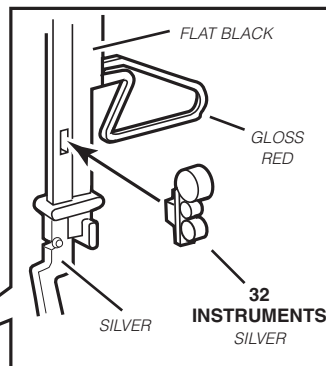

4

STRUTS ASSEMBLY CONTINUED

D

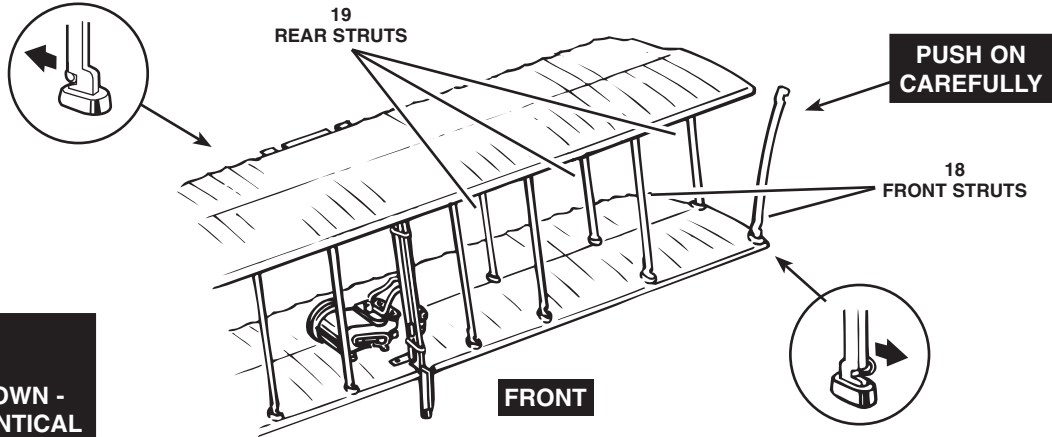

5

RIGGING ASSEMBLY

A

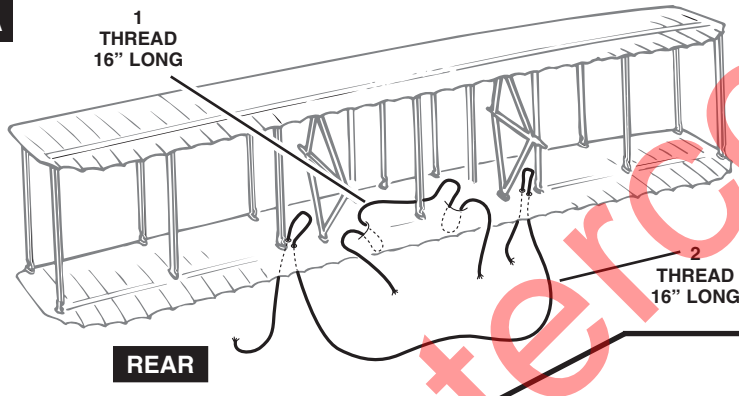

NOTE: USE THIN GRAY THREAD (SUPPLIED) FOR RIGGING. THE RIGGING IS THE MOST DIFFICULT PART OF THE ASSEMBLY AND REQUIRES PATIENCE.

NOTE: LET THREAD HANG. FINISH RIGGING IN STEP 8

B

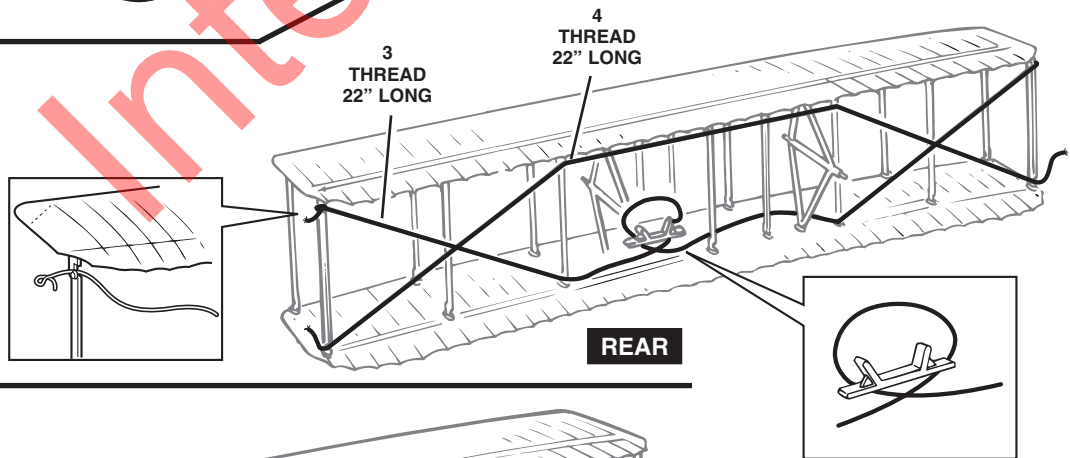

C

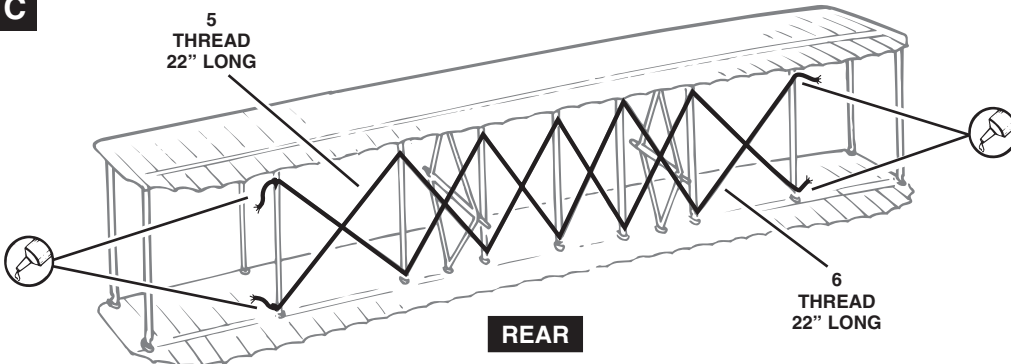

5

RIGGING ASSEMBLY CONTINUED

D

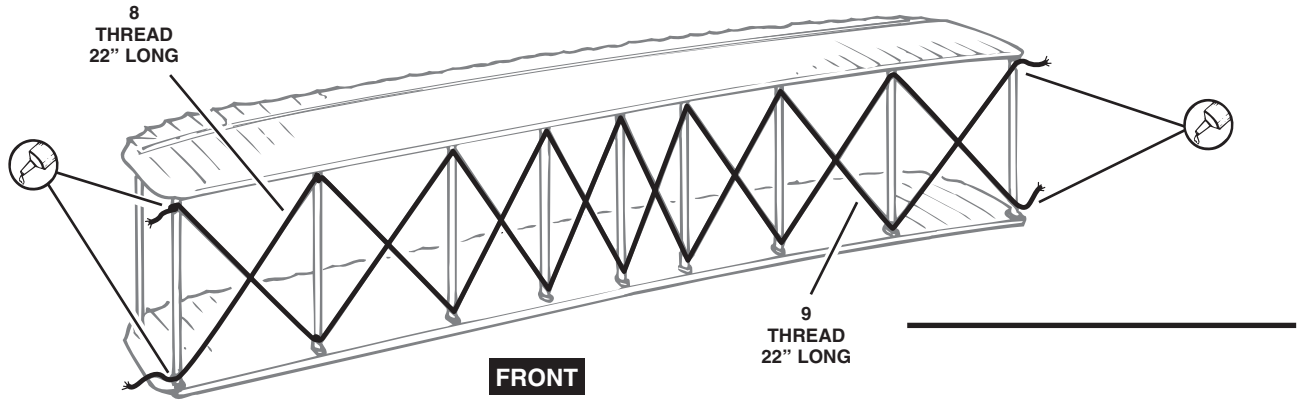

E

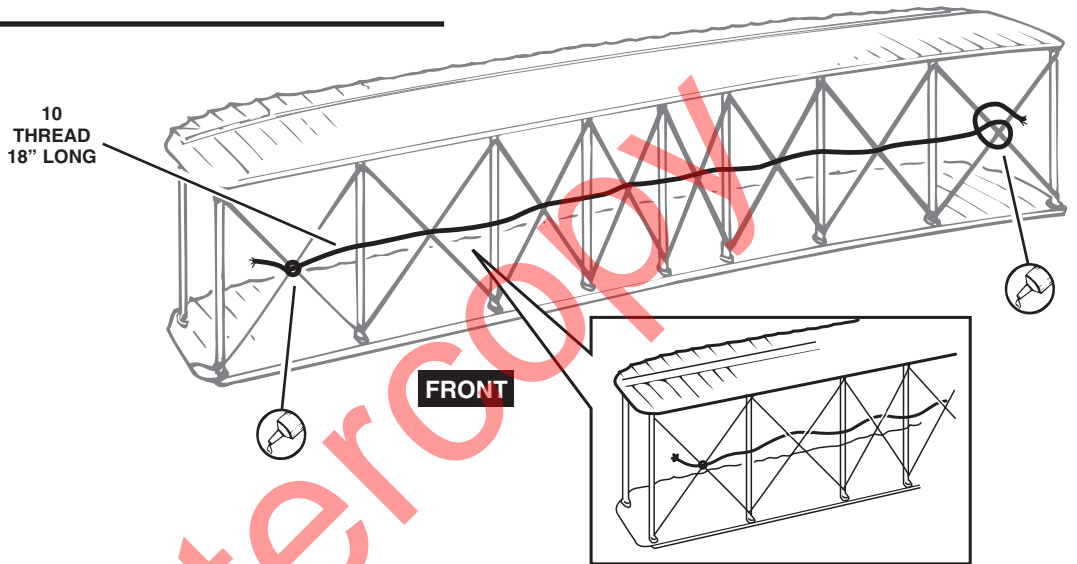

6

LANDING SKID ASSEMBLY

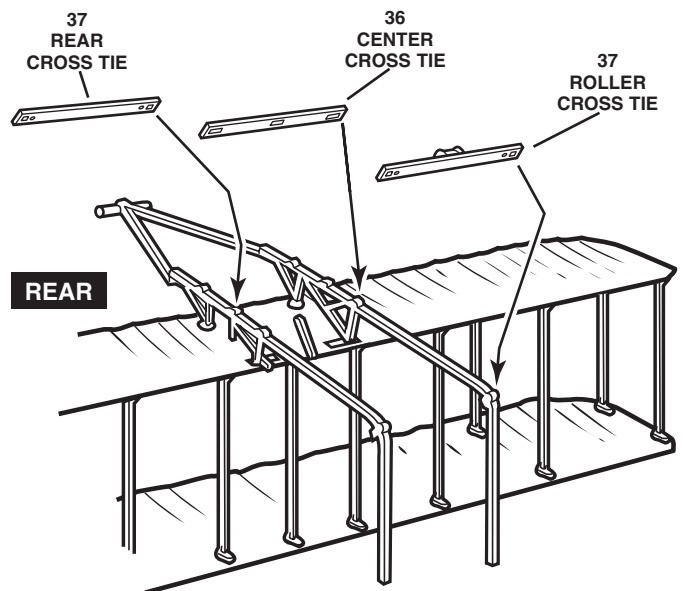
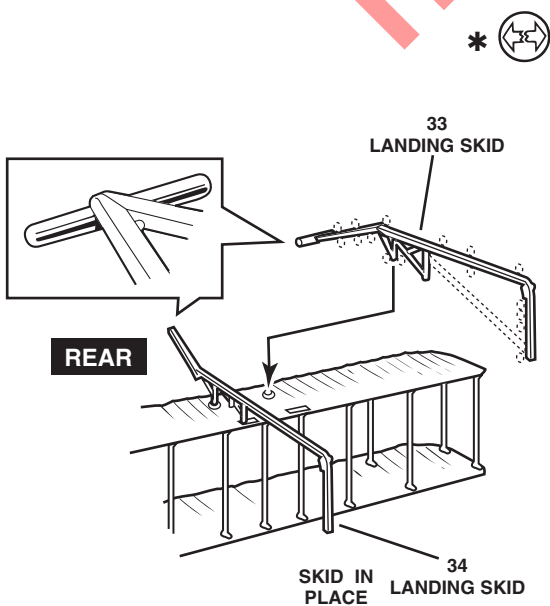

7

FRONT RUDDER AND PILOT ASSEMBLY

A

COMPLETED
FRONT RUDDER
ASSEMBLY

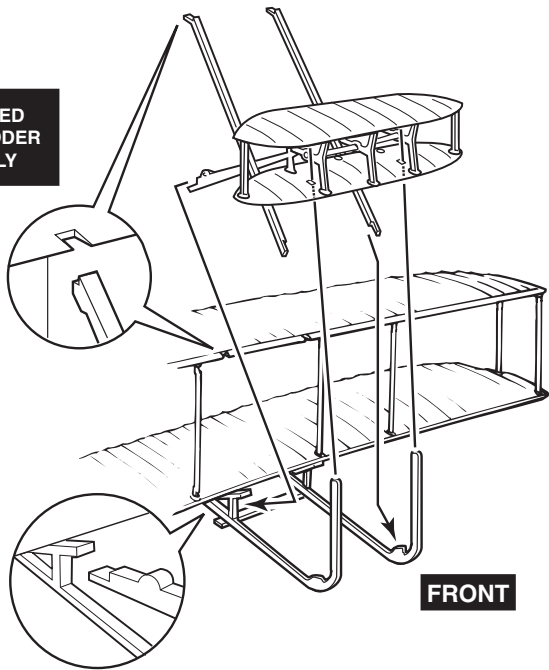

B

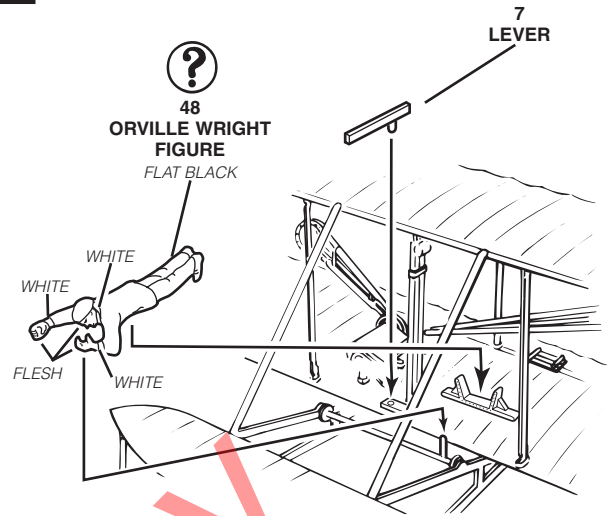

C

REAR RUDDER
ASSEMBLY

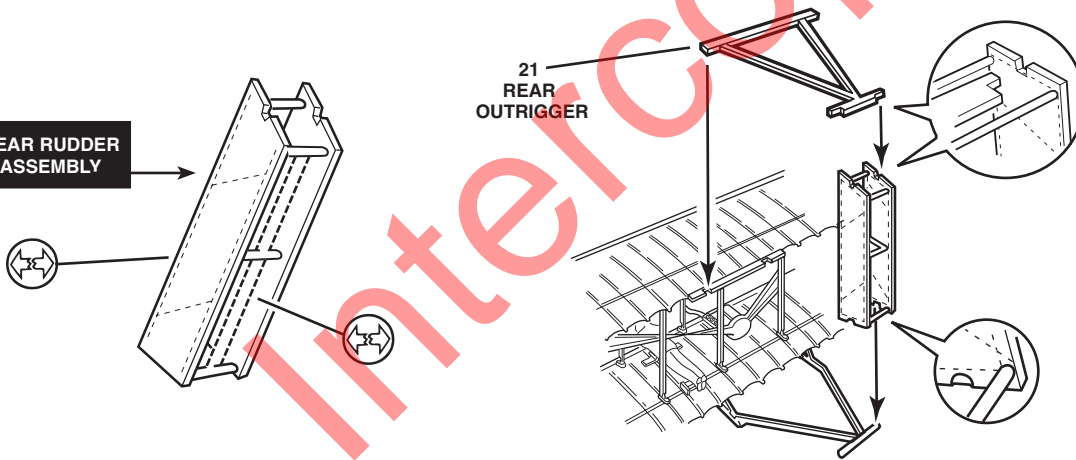

8

BOTTOM RIGGING

A

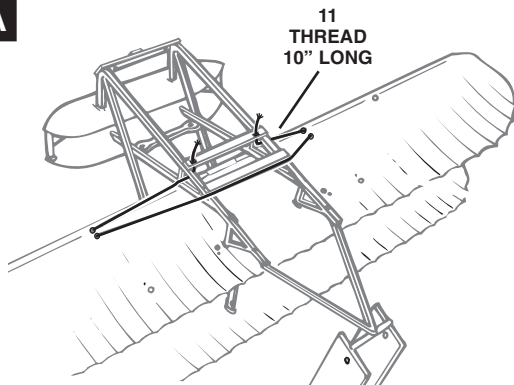

B

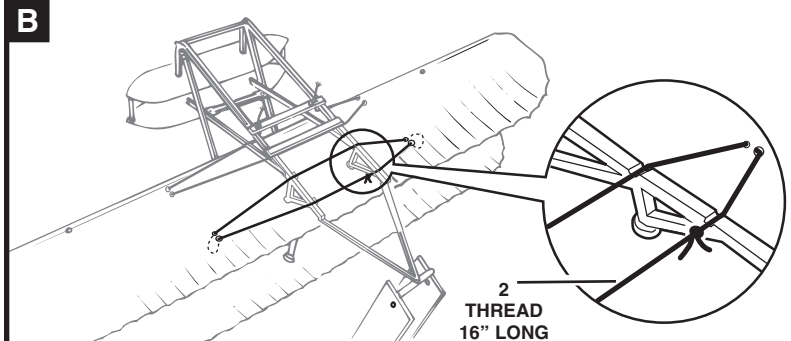

8

BOTTOM RIGGING CONTINUED

C

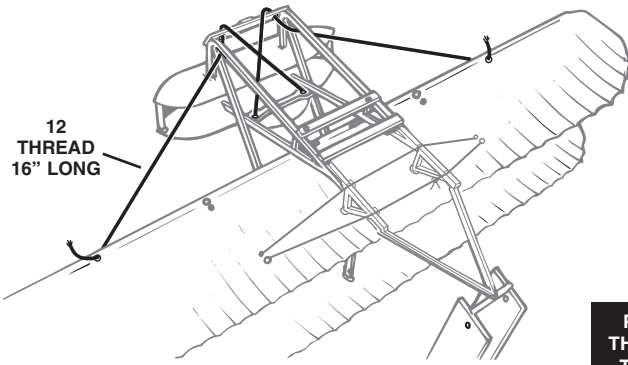

D

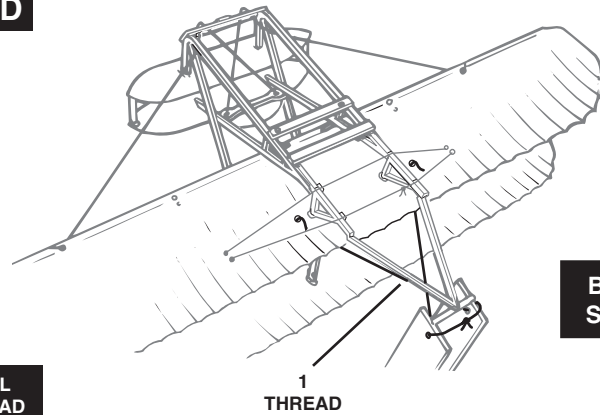

PULL
THREAD
TIGHT

BOTH
SIDES

E

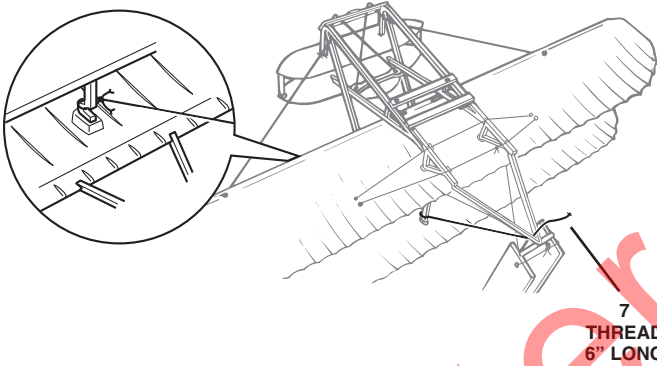

7
THREAD
6" LONG

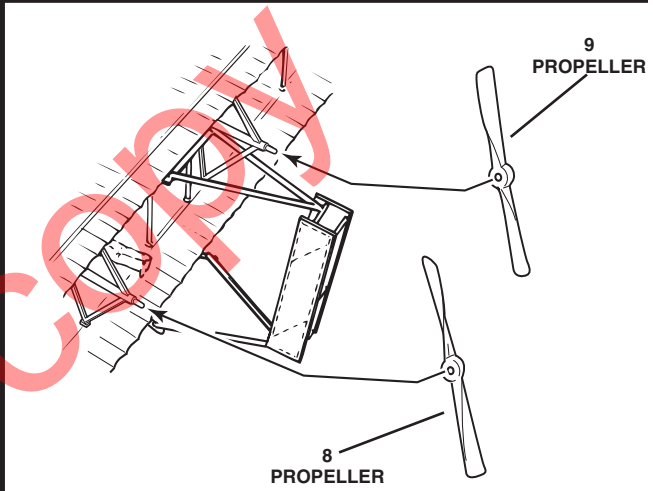

9
PROPELLER

8
PROPELLER

9

FINAL ASSEMBLY

A

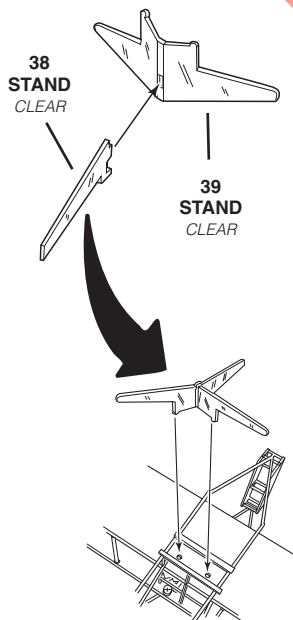

B

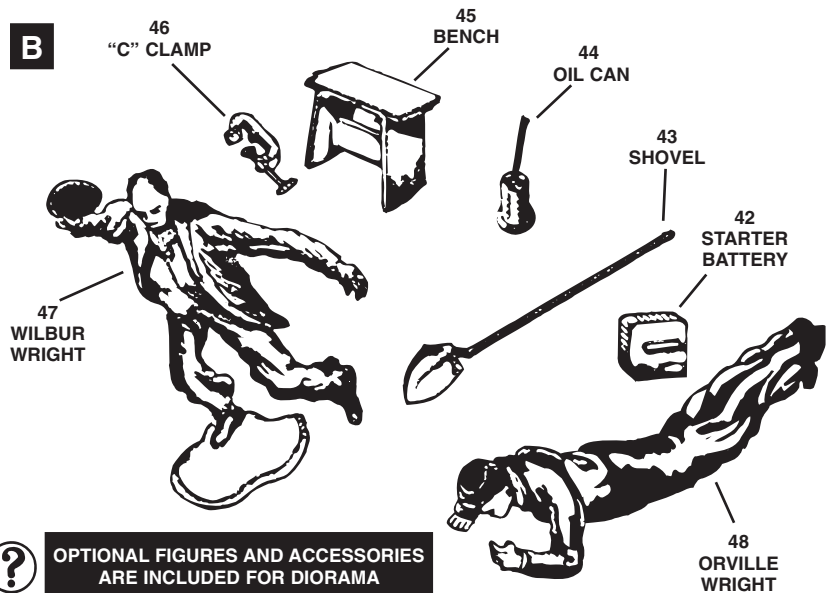

?
OPTIONAL FIGURES AND ACCESSORIES
ARE INCLUDED FOR DIORAMA